



ARCHGARD

FIREPLACE PRODUCTS



27-DVIE22

GAS FIRED VENTED ROOM HEATER (DIRECT VENT)

S/N 270000 AND UP

USERS' INSTALLATION OPERATION AND MAINTENANCE MANUAL

WARNING: If the information in this manual is not followed exactly, a fire or explosion may result causing property damage, personal injury or loss of life.

Do not store or use gasoline or other flammable vapors and liquids in the vicinity of this or any other appliance.

WHAT TO DO IF YOU SMELL GAS:

- * Do not try to light any appliance.
- * Do not touch any electrical switch; do not use any phone in your building.
- * Immediately call your gas supplier from a neighbor's phone. Follow the gas supplier's instructions.
- * If you cannot reach your gas supplier, call the fire department.

Installation and service must be performed by a qualified installer, service agency or the gas supplier.

This appliance may be installed in an aftermarket permanently located, manufactured home (USA only) or mobile home, where not prohibited by local codes.

This appliance is only for use with the type of gas indicated on the rating plate. This appliance is not convertible for use with other gases, unless a certified kit is used.

*Conversion kit required for Propane use

WARNING



**HOT GLASS WILL
CAUSE BURNS**

**DO NOT TOUCH GLASS
UNTIL COOLED**

**NEVER ALLOW CHILDREN
TO TOUCH GLASS**

INSTALLER: Leave this manual with the appliance.
CONSUMER: Retain this manual for future reference.

Tested and
listed by



NATIONAL
FIREPLACE
INSTITUTE



www.nficertified.org

We recommend that our gas hearth products be installed and serviced by professionals who are certified in the U.S. by the National Fireplace Institute® (NFI) as NFI Gas Specialists.

fire-parts.com

INTRODUCTION

Congratulations on choosing an Archgard Gas Fireplace!

The 27-DVIE22 is one of the most advanced Direct Vent Insert heaters available today. It is solidly designed using the latest technology and manufactured to the highest quality. It is our aim to provide you with an appliance for many trouble-free years of reliable service.

Some of the many features of your 27-DVIE22 are:

- **Heater Classification** The 27-DVIE22 is classified as a heating appliance. Therefore, it uses Direct Vent safety technology and it is suitable for continuously operated zone heating.
- **High Efficiency** The 27-DVIE22 has one of the highest efficiencies of any Direct Vent gas insert, which means that it is less expensive to operate.
- **Adjustable Fan Speed** Each 27-DVIE22 comes complete with 6 level adjustable speed controlled circulation fan.
- **Adjustable Flame** The flame aesthetics and heat output can be adjusted to suit the owner's liking and heating needs.
- **Solid Construction** The 27-DVIE22 is mainly constructed of 16 and 18 gauge galvanized and aluminized coated steel for long life and durability.
- **Optional Accessories** Check with your Authorized Archgard Dealer for a full complement of decorative accessories to suit your home's décor and your tastes.
- **Electronic Control System** The 27-DVIE22 uses a gas control valve that is operated by a Multifunction Remote Control. It can be used as either an Intermittent or Standing Pilot system.

Fireplace Model Number: 27-DVIE22 Serial Number: _____

Date of Installation: _____

Type of Gas Used by the Fireplace: Natural Gas Propane

Dealer's Name & Address: _____

Dealer's Phone Number: _____

TABLE OF CONTENTS

Caution and Safety Instructions	5
Appliance Certification, Installation Codes and Specifications	6
Rating Plate	7
Configure the Fireplace and Control Panel Locations	8
Minimum Fireplace Opening Dimensions and Sealing the Vent	9
Factory Built (metal) Fireplace Requirements	10-11
Mantle and Sidewall Clearance to Combustibles	12
Gas Connections	13
Conversion Kit Instructions	14-15
Appliance Description, Leveling the Appliance and Electrical Requirements	16
Venting Instructions	17-18
Surround Installation and Rocker Switch Wiring	19
Log Placement	20-24
Glass Door Removal / If Your Glass Should Break	25
Final Installation Check and Initial Operation	26
First Fire and Lighting Instructions (CAUTION)	27
Lighting Instructions on Rating Plate	28
Remote Control Setup and Operation	29-35
SIT Intermittent Ignition Sequence	36
Maintenance and Cleaning the Appliance	37
Servicing Under Warranty and Adjusting Primary Air	38
Checking Inlet/Outlet gas pressures, Adjusting Pilot and Convertible Pilot Orifice	39
Replacing Convection Blower	40
Wiring Schematic	41
Warranty	42
Frequently Asked Questions	43
Replacement Parts	44
Notes	45
Warranty Registration Card	46

F O R Y O U R S A F E T Y

Do not install or operate your Archgard 27-DVIE22 without reading and understanding this manual. Any installation or operational deviation from this instruction manual voids the Archgard Industries Warranty and may prove hazardous.

C A U T I O N

- This appliance must be installed by a qualified gas installer and the installation must conform to the installation codes.
- Provide adequate clearance around air openings. Never obstruct front openings.
- Ensure adequate clearances for proper operation and servicing of the appliance.
- This appliance must be properly connected to an approved venting system and must not be connected to a chimney flue serving a separate solid fuel burning appliance.
- Provide adequate clearance around the intake and exhaust openings

A T T E N T I O N

We recommend that our gas hearth products be installed and serviced by professionals who are certified in the U.S. by the National Fireplace Institute® (NFI) as NFI Gas Specialists.

SAFETY

Due to high temperatures, the appliance should be located out of traffic and away from furniture and draperies.

Children and adults should be alerted to the hazards of high surface temperature and stay away to avoid burns or clothing ignition.

Young children should be carefully supervised when they are in the same room as the appliance. Toddlers, young children and others may be susceptible to accidental contact burns. A physical barrier is recommended if there are at risk individuals in the house. To restrict access to a fireplace or stove, install an adjustable safety gate to keep toddlers, young children and other at risk individuals out of the room and away from hot surfaces.

Clothing or other flammable material should not be placed on or near the appliance.

Do not operate with cracked or broken glass. Be careful not to strike or slam the glass.

Any safety screen or guard removed for servicing an appliance must be replaced prior to operating.

Installation and Repair should be done by a qualified service person. The appliance should be inspected before use and at least annually by a professional service person. More frequent cleaning may be required due to excessive lint from carpeting, bedding materials, etc. It is imperative that the control compartments, burners and circulating air passageways of the appliance are kept clean.

Do not use this appliance if any part has been under water. Immediately call a qualified service technician to inspect the appliance and to replace any part of the control system and any gas control which has been under water.

APPLIANCE CERTIFICATION

This appliance was listed by LABTEST Certification Inc to the following USA and Canadian gas appliance standards.

- ANSI Z21.88-2009/CSA 2.33-2009 Vented Gas Fireplace Heaters
- CAN/CGA-2.17-M91, Gas-Fired Appliances for Use at High Altitudes
- CSA P.4.1-09 testing method for measuring annual fireplace efficiency.

The listing label is attached to the appliance on the bottom right side of the appliance.

A copy is shown on page

Please contact Archgard Industries Ltd., if you have any questions regarding the certification of this appliance.

INSTALLATION CODES

This appliance must be installed by a qualified gas appliance installer. The installation must conform with the local codes or, in the absence of local codes, with the current *National Fuel Gas Code ANSI Z223.1/ NFPA 54*, or the *Natural Gas and Propane Installation Code CSA-B149.1* in Canada.

The appliance, when installed, must be electrically grounded in accordance with local codes or, in the absence of local codes, with the *National Electrical Code ANSI/NFPA No. 70*, or the *Canadian Electrical Code CSA C22.1*.

A manufactured home or mobile home OEM installation must conform with the *Manufactured Home Construction and safety Standard, Title 24 CFR, Part 3280*, or, when such a standard is not applicable, the *Standard for Manufactured Home Installations, ANSI/NCSBCS A225.1*, or *Standard for gas Equipped Recreational Vehicles and Mobile Housing, CSA Z240.4*.

SPECIFICATIONS

	Natural Gas (NG)	Propane (LP)
Manifold Pressure	3.5 in. W.C. (0.9 kPa)	10.0 in. W.C. (2.5 kPa)
Min. Supply Pressure	5 in. W.C. (1.2 kPa)	11.0 in. W.C. (2.8 kPa)
Max Supply Pressure	14.0 in. W.C. (3.5 kPa)	14.0 in. W.C. (3.5 kPa)
Orifice Size	#43 DMS (2.25 mm dia)	#54 DMS (1.36 mm dia)
Nominal Input Rating	15,000 - 22,400 BTU/h(4.5 - 6.56kW)	16,500 - 21,000 BTU/h (4.8 -6.15kW)
Electrical Rating	120 VAC, 60Hz less than 2 A.	120 VAC, 60Hz less than 2 A.
Gas Control	SIT 885 Proflame	SIT 885 Proflame
Altitude	0 - 4,500 ft. (0 - 1372 M)	0 - 4,500 ft. (0 - 1372 M)
Primary Air Opening	1/4" (6 mm) OPEN	FULLY OPEN

HIGH ALTITUDE INSTALLATION

When installing this appliance beyond 4500 ft. (1372 M) above sea level, the appliance must be properly de-rated and installed according to local codes, in the absence of local codes, with the current *National Fuel Gas Code, ANSI Z223.1/ NFPA 54*, in the US or Installation Code, *CAN/CGA-B149, in Canada*.

RATING PLATE



DO NOT REMOVE THIS LABEL

de série / Serial # **LC**

NE PAS ENLEVER CETTE ÉTIQUETTE

MODEL / MODÈLE: 27-DVIE22

C
 L

NG / NATURAL
 LP / PROPANE

LISTED VENTED GAS FIREPLACE HEATER and GAS-FIRED APPLIANCES FOR USE AT HIGH ALTITUDES. RADIATEUR VENTILE, CIRCULATEUR DU TYPE VENTILATEUR. Tested to / Testée selon les normes : ANSI Z21.88-2009 / CSA 2.33-2009 and CAN/CGA-2.17-M91 This vented gas fireplace heater is not for use with air filters. Certified for use in both CANADA and USA. / Certifié pour utilisation dans le Canada et les ÉTATS-UNIS.

VENTED GAS FIREPLACE HEATER-NOT FOR USE WITH SOLID FUEL.

SIT 885 Valve

	NG	LPG
Input rating / Entrée assignée	15,500 - 22,400 BTU/hr (4.54 - 6.56 kW)	16,500 - 21,000 BTU/hr (4.84 - 6.15 kW)
Manifold pressure / Pression d'admission	3.5 in. W.C. (0.9 kPa)	10.0 in. W.C. (2.5 kPa)
Orifice size / Dimension de l'orifice	#43 DMS (2.25 mm dia.)	#54 DMS (1.36 mm dia.)
Minimum supply pressure for purpose of input adjustment / Pression minimale d'alimentation pour le but d'ajustement de contribution	5.0 in. W.C. (1.2 kPa)	11.0 in. W.C. (2.8 kPa)
Burner Primary Air Setting	1/4" (6 mm) Open	100% Open
Altitude / Elevation	0 - 4500 ft (0 - 1372 m)	0 - 4500 ft (0 - 1372 m)
Electrical rating / Tension électrique	120 VAC, 60 Hz less than 2 A. / 120 V, 60 Hz Moins que 2 A.	
Keep burner and control compartment clean. See Instructions accompanying the heater. Maintenir propres le brûleur et le compartiment de commande. Voir les instructions relatives à l'installation et au fonctionnement qui accompagnent le radiateur. Optional fuel conversion kit : See Manual	Minimum clearances to Combustibles / Distances: Minimales entre l'appareil et les combustibles: Sides from glass door frame/ Côtes: 8" (203 mm) Mantle / Manteau: 8" deep (305 mm) at min 11" (991 mm) from top of door See Owner's Manual for additional clearances	

This appliance must be installed in accordance with local codes, if any; if none, follow the National Fuel Gas Code, ANSI Z223.1/ NFPA 54, or Natural Gas and Propane Installation Codes, CSA B149.1. Electrical connections and grounding must be in accordance with local codes, if any; if none, follow the current CAN/CSA C22.1 in Canada and ANSI/NFPA 70 in the US. This appliance is certified for installation in a bedroom or a bed sitting room. This appliance is only for use with the gas indicated on the rating plate and may be installed in an aftermarket, permanently located, manufactured (mobile) home where not prohibited by local codes. See owner's manual for details. This appliance is not convertible with other gases, unless a certified kit is used.
FOR USE WITH GLASS DOORS CERTIFIED WITH THIS APPLIANCE ONLY.

Il faut que cet appareil soit installé selon les codes locaux, s'il y en a; sinon, suivre le CAN/CGA-B149 actuel au Canada et ANSI Z223.1 aux É.-U. Il faut que le raccordement électrique et la mise à la masse soient en conformité avec les codes locaux, s'il y en a; sinon, suivre le CAN/CSA C22.1 actuel au Canada et ANSI/NFPA 70 aux É.-U. Cet appareil est certifié pour l'installation dans une chambre à coucher ou une pièce qui sert de chambre.

Made in Canada by / Fabrique au Canada par:
Archgard Industries Ltd.
7116 Beatty Dr., Mission, B.C.

FEB 2014 303-6027-1



NATIONAL
FIREPLACE
INSTITUTE



We recommend that our gas hearth products be installed and serviced by professionals who are certified in the U.S. by the National Fireplace Institute® (NFI) as NFI Gas Specialists.

CONFIGURE THE FIREPLACE - CONTROL PANEL LOCATIONS

The control panels can be mounted in the following different ways. They are shipped in the “Controls In” configuration. They can be moved to the “Controls Out” configuration by removing the two mounting screw on each side and swinging the panels out and re-installing the screws. They can also be disconnected and placed remotely within the limits of the gas connections and electrical wiring making sure to place them away from any heat source over 150 degrees Fahrenheit or 65 degrees Celsius

27-DVIE22

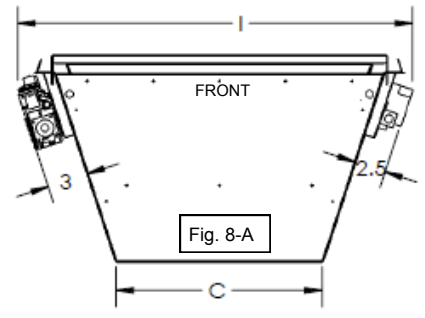

“CONTROLS IN” CONFIGURATION
Use Shallow Trim

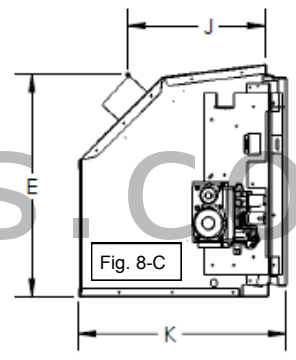
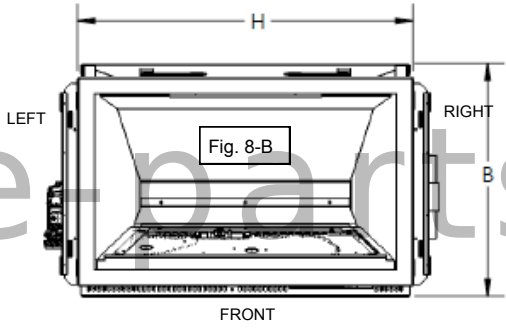

A	B	C	D	E	G	H	J	K	I
27-1/2"	17-5/8"	15-5/8"	14-1/2"	16-3/4"	38-1/4"	25-3/8"	10-3/8"	15-3/4"	29-7/8"
697MM	448MM	396MM	406MM	426MM	972MM	644MM	264MM	400MM	759MM

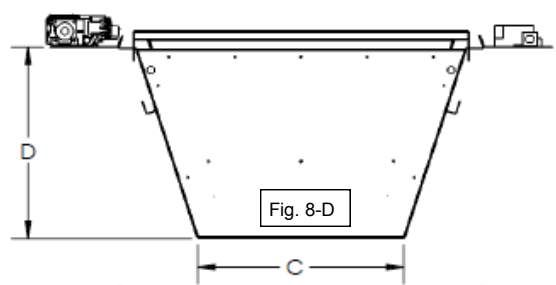

“CONTROLS OUT” CONFIGURATION
Use Deep Trim

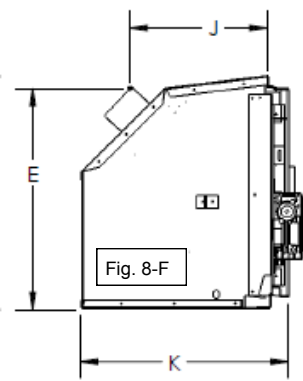
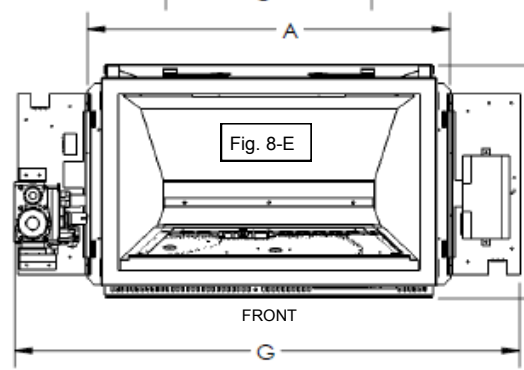

Main On/Off switch must be connected to the surround switch or jumpered and in the “on” position for the remote to operate the fireplace

MINIMUM FIREPLACE OPENING DIMENSIONS

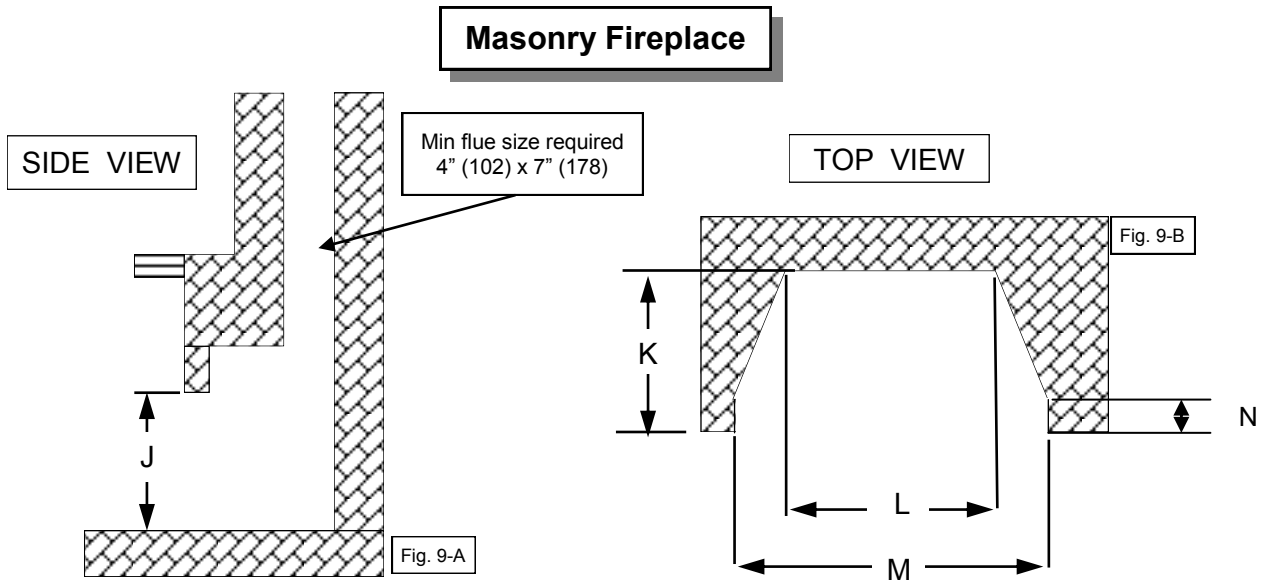

	J	K	L	M	N
DIMENSIONS "Controls Out"	17-3/4" (451 mm)	15" (381 mm)	16" (406 mm)	25 1/2" (648 mm)	0"
DIMENSIONS "Controls In"	17-3/4" (451 mm)	15 1/2" (381mm)	16" (406 mm)	30" (762 mm)	3" (76mm)

A T T E N T I O N

This fireplace has been designed to be installed into a Masonry or Factory Build Wood Burning Fireplaces **ONLY**. Never attempt to install the appliance into a combustible enclosure. If the information in these instructions are not followed exactly, a fire or explosion may result causing property damage, personal injury or loss of life.

SEALING THE VENT

Secure the flexible liner at the top of the fireplace and at the termination. **DO NOT** use silicone as this will void the flame sensor warranty. Use mil-pac or other non silicone sealant and three (3) screws or gear clamps to seal the liner at each end.

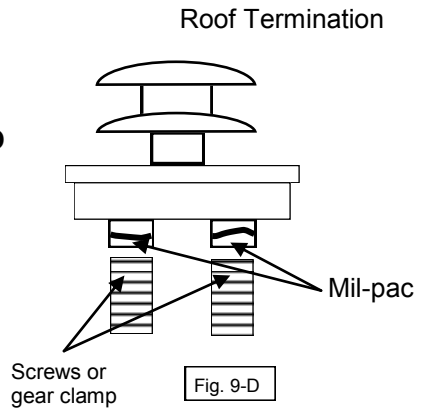
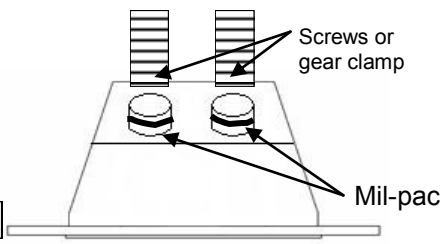

DO NOT USE SILICONE TO SEAL VENT

Factory –Built (metal) Wood-Burning Fireplace Opening Requirements

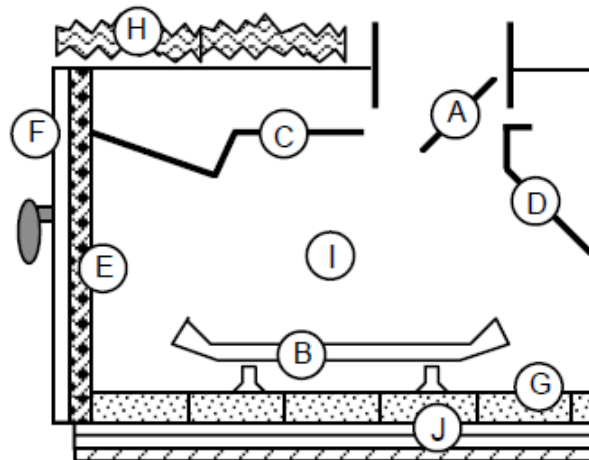

Fig. 10-A

I N S T A L L E R N O T E S

The installer must mechanically attach a marking (supplied in the manual bag) to the inside of the firebox of the fireplace into which the gas fireplace insert is installed indicating that it has been altered and is no longer suitable for burning the original fuel unless the removed parts are reinstalled.

Cutting of any sheet-metal parts of the fireplace, in which the gas fireplace insert is to be installed, is prohibited unless following the directions below.

If the factory-built fireplace has no gas access hole (s) provided, an access hole of 1 1/2" (38.1 mm) or less may be drilled through the lower sides or bottom of the firebox in a proper workmanship-like manner. This access hole must be plugged with non-combustible insulation after the gas supply line has been installed.

The fireplace flue damper (A) must be fully blocked open or removed for installation of the gas fireplace insert.

The fireplace and fireplace chimney must be clean and in good working order and constructed of non-combustible materials. The chimney cleanouts must fit properly.

Refractory (G & I), glass doors (F), screen rails & screen mesh (E) and log grates (B) can be removed from the fireplace before installing the gas fireplace insert.

Smoke shelves (C) and baffles (D) may be removed if attached by mechanical fasteners. Trim panels must not seal ventilation openings in the fireplace.

N O T E

The metal floor of the firebox may be removed only if the following is strictly adhered to.

The metal floor (J) may be removed to allow additional room for installation of the insert. If the floor is removed the insert must be placed directly on the metal base of the metal fireplace. **Under no circumstance can it be placed directly on a combustible material.**

A T T E N T I O N

Any parts that are removed must be saved and re-installed if the insert is ever removed.

W A R N I N G

Failure to position the parts in accordance with these diagrams or failure to use only parts specifically approved with this appliance may result in property damage or personal injury.

W A R N I N G

Any hearth extending out in front of the insert must not have any portion above 7" below the bottom of the unit made from combustible materials. This includes any type of framing underneath a non-combustible material such as tile, marble or stone. Any material below 7" can be combustible.

N O T E

All specified clearances must be maintained from the top surface of carpeting, tile, etc.

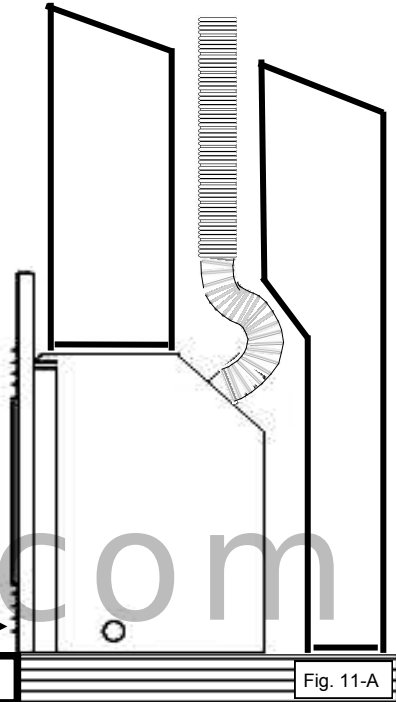

fire-parts.com

C A U T I O N

This appliance is designed for use in any masonry or factory-built, wood-burning fireplace. It cannot be enclosed by combustible material and used as a built-in gas fireplace.

N O T E

If existing wood fireplace hearth protection is removed it must be replaced by a non-combustible hearth protection 7" thick, extending a minimum of 16" (406 mm) from the front of the fireplace insert or have a minimum 7" (178 mm) clearance below the level of the bottom of the insert.

N O T E

All specified clearances must be maintained from the top surface of carpeting, tile, etc.

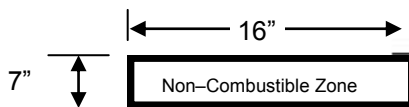
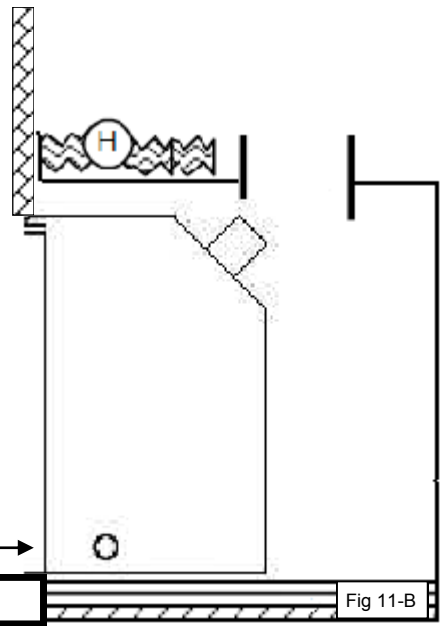

MANTLE CLEARANCES

W A R N I N G

Failure to position the parts in accordance with these diagrams or failure to use only parts specifically approved with this appliance may result in property damage or personal injury.

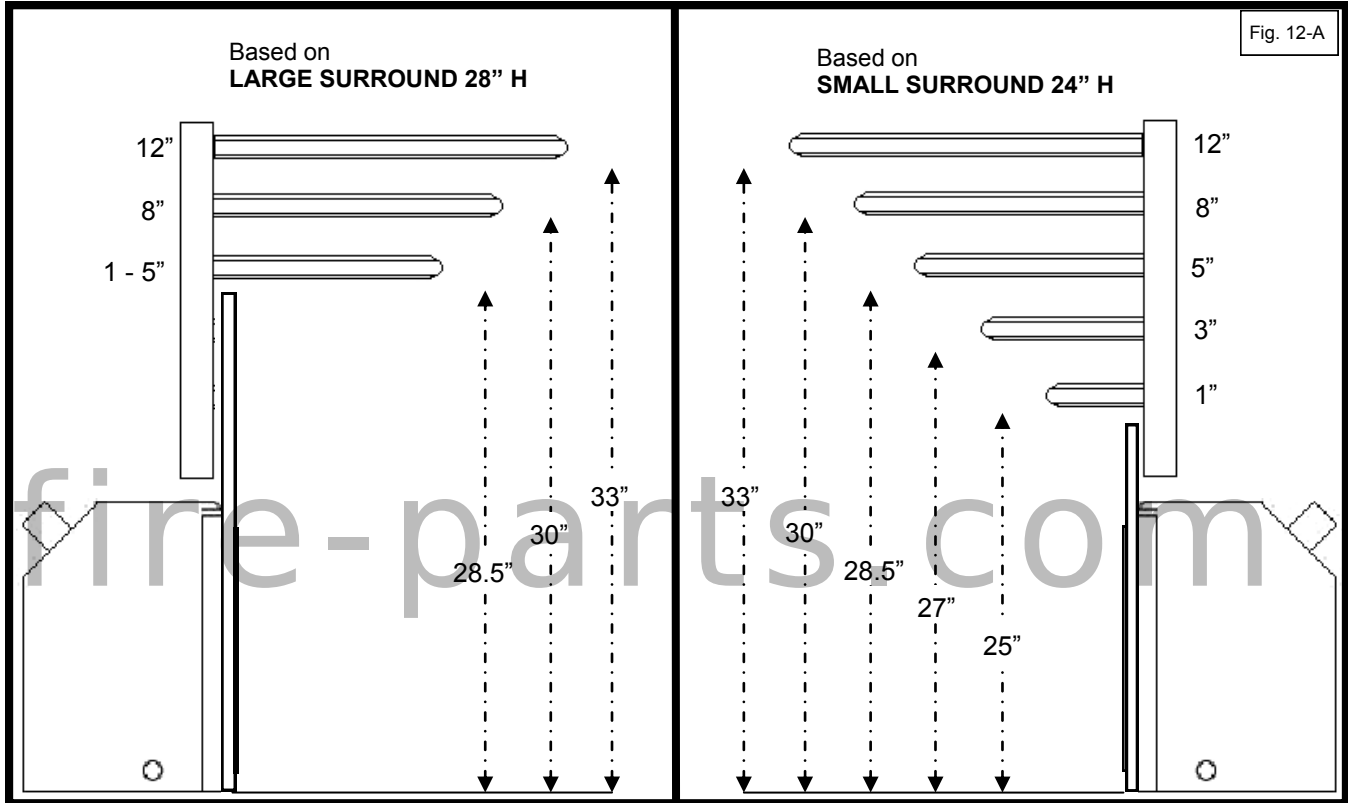

N O T E

Mantle depth of less than 1" is not considered a mantle

SIDEWALL CLEARANCES

Minimum 8" (204 mm) clearance is required from the glass door frame to a sidewall or mantle support.

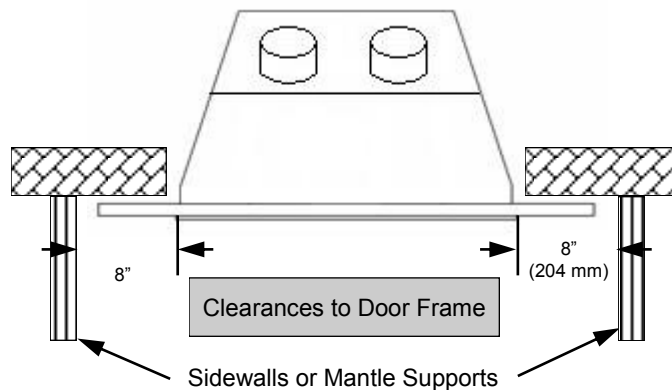

Fig. 12-B

GAS CONNECTIONS

Before connecting the appliance to the gas supply line, double check that the appliance you have purchased is designed for the gas type you are using. The gas type markings are located on the certification label and also on the appliance's gas valve.

Adequate clearance for proper installation and checking of the gas connections must be provided. **All gas connections must be checked for gas leaks.**

Have your gas supplier or a qualified gas fitter run a gas supply line into the fireplace. The line must be properly sized and fitted according to the installation codes. Immediately upstream of the supply connection, the fitter shall provide an accessible manual shut-off valve. When connecting the supply line to the gas valve, the installer shall brace the gas valve to ensure that the gas valve is not moved from its bracket. If the valve is not braced when the supply line is connected, the valve may be moved and cause a "break" in the main burner supply line. Such damage is not covered by the manufacturer's warranty.

C A U T I O N

The appliance and its individual shutoff valve must be disconnected from the gas supply piping system during any pressure-testing of that system at test pressures in excess of 1/2 psig (3.5 kPa). The appliance must be isolated from the gas supply piping system by closing its individual manual shutoff valve during any pressure-testing of the gas supply piping system at test pressures equal to or less than 1/2 psig (3.5 kPa). Failure to do so will damage the appliance's gas valve. Such damage is not covered by the manufacturer's warranty.

Natural Gas Pressure Settings:

The inlet supply or line pressure must be a minimum of 5" W.C. (1.2 kPa) and a maximum of 14" W.C. (3.5 kPa). The orifice is a #43 DMS (2.25mm) drill size.

<u>ELEVATION</u>	<u>INPUT RATING</u>
0-4500 ft (0-1372 M)	22,400 BTU/hr (9.6 kW)
4500 ft (1372 M) and above.	22,400 BTU/hr (9.6 kW) less 4% per 1000 ft. (305 M)

Please contact your local distributor for the appropriate orifice size you require.

Propane Pressure Settings:

The inlet supply or line pressure must be a minimum of 11" W.C. (2.8 kPa) and a maximum of 14" W.C. (3.5 kPa). The orifice is a #54 DMS (1.36 mm) drill size.

<u>ELEVATION</u>	<u>INPUT RATING</u>
0-4500 ft. (0-1372 M)	21,000 BTU/hr (9.02 kW)
4500 ft. (1372 M) and above.	21,000 BTU/hr (9.02 kW) less 4% per 1000 ft. (305 M)

Please contact your local distributor for the appropriate orifice size you require.

I N S T A L L E R S N O T E

THE INPUT RATING SHOULD BE CHECKED ON INITIAL START-UP OF THIS APPLIANCE.

To do this, reduce the background flow rate, time the meter.

Light the fireplace and take another reading after 15 minutes of operation.

Check with your gas supplier for the gas BTU content at your elevation.

Input is the rate of flow multiplied by the heating value of the gas (3600 x Calorific Value) divided by the time (in seconds) it takes for (1) rotation of the 1 cubic foot dial on the meter.

Adjust the manifold pressure so that the unit does not operate above the rated input.

CONVERSION KIT INSTRUCTIONS

WARNING

The conversion kit shall be installed by a qualified service agency in accordance with the manufacturers instructions and all applicable codes and requirements of the authority having jurisdiction. If the information in these instructions is **not** followed exactly, a fire, explosion or productions of carbon monoxide may result, causing property damage, personal injury or loss of life. The qualified service agency is responsible for proper installation of this kit.

The installation is not proper and complete until operation of the converted appliance is checked as specified in the instructions supplied with the kit. Refer to appliance owner's manual or product data plate for proper inlet and manifold pressure adjustments and orifice sizing.

IMPORTANT

This fireplace is Natural gas ready. If converting to LP gas, follow instructions below

KIT NUMBERS: **27-CKELP** for LP gas and **27-CKENG** for Natural Gas

KIT INCLUDES:

- 1- Gas conversion label (303-0128)
- 1- Burner orifice (301-0068) (#54 DMS for LPG) (#43 DMS for NG)
- 1- Instruction Sheet
- 1- SIT 885 Valve conversion regulator c/w instructions & gas type label (0.907.012) LPG (0.907.013) NG

FOR YOUR SAFETY

SHUT OFF GAS SUPPLY AND ELECTRICAL POWER TO FIREPLACE BEFORE BEGINNING THE GAS CONVERSION

PREPARE THE FIREPLACE

- Remove the surround, glass door assembly, logs/media and brick/panels (if applicable).
- Remove the burner side brackets and the front ember ledge. The ledge lifts up and out.
- Remove burner . Three screws along the top edge of the burner secure it to in place.

Remove the burner orifice using a 1/2" wrench. Replace with the orifice supplied with the conversion kit. Use a small amount of pipe sealant on the threads of the orifice holder.

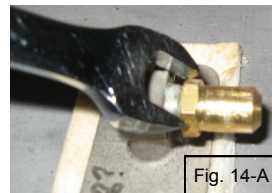
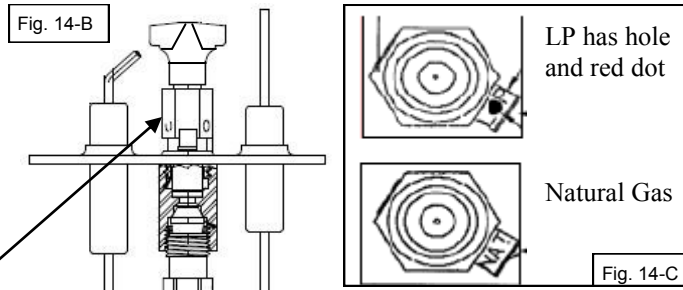

Fig. 14-A

PILOT CONVERSION

Using a 7/16" wrench and loosen the pilot hood 1/4 turn. Slide the tab at the bottom of the orifice hood all the way so the red side (propane) with the hole in it is showing. Tighten the pilot hood back up so that it is lined up with the two probes on both sides of the pilot assembly.



CONVERSION KIT INSTRUCTIONS, cont.

CONVERT THE GAS VALVE

STEPPER MOTOR PRESSURE REGULATOR CONVERSION KIT INSTALLATION OR REPLACEMENT INSTRUCTIONS.

Verify that the following items are present in the package.

- Pressure regulator assembly (E)
- Two (2) screws (F)
- Identification label (G)
- Installation instructions (this document).

1 Shut off the gas supply to the valve and shut down the electric supply.

2 See Fig. 1. Using a Torx T20, or slotted screwdriver, remove and discard the two (2) pressure regulator mounting screws (A), pressure regulator tower (B), and the spring and diaphragm assembly (C), (if applicable).

3 Ensure the rubber gasket (D), which is prefitted as part of assembly (E), is properly positioned, see Fig. 2, otherwise fit the gasket as shown Fig. 2.

4 Install the new STEPPER MOTOR pressure regulator assembly, as shown in Fig. 3 and Fig. 4. Use the supplied screws (F), M4 x 0.7 threaded, length of thread L=(16 mm + 0 - 0.5 mm), steel material, resistance class 8.8 (see Fig. 5).

5 Manually thread the two conversion kit mounting screws into the valve body. Use a standard screwdriver or T20 Torx bit and tighten to the screws with a fixing torque of 25lb-in ± 5%.

IN THE EVENT THAT THE THREADS OF THE VALVE ARE STRIPPED OR DAMAGED, REPLACE THE VALVE.

6 Install the enclosed identification label (G) to the valve body where it can be easily seen.

7 Make STEPPER MOTOR and valve electrical connections, apply gas to system and relight appliance according to manufacturers instructions.

8 With the main burner "ON", test the new pressure regulator assembly for leaks using a soap solution.

9 Relight the main burner and verify proper burner ignition and operation.

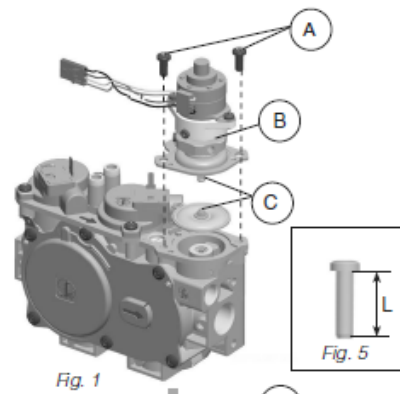

Fig. 1

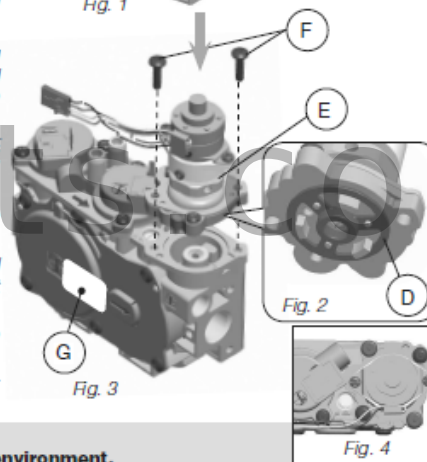

Fig. 3

Fig. 2

Fig. 4

WARNING!
Installation should be carried out in a clean environment.

WARNING!
This modulating conversion kit must ONLY be applied as part of a conversion kit supplied by the APPLIANCE MANUFACTURER for the specific appliance, and type of gas, being converted.

WARNING!
Correct operation of the system cannot be guaranteed if the conversion kit or valve has been dropped or has sustained a strong impact.

INSTALLER NOTICE. These instructions must be left with appliance.

COMPLETE THE CONVERSION

Turn on the gas and electrical supplies.
Turn on the fireplace so the burner is on
Check for leaks at all connections.

Test inlet and outlet pressure. Visually check pilot flame. Flame should envelope top of the flame sensor and extend forward onto the burner. To adjust pilot turn the pilot adjustment screw on the control valve clockwise to decrease or counter clockwise to increase pilot flame.

Turn fireplace off

Affix gas type label to the rating plate label. (Bottom right side, under the door frame of insert on pull chain)

Complete the conversion label and affix to valve assembly plate.

Re-install the burner, brick, logs, embers and door. (per the instructions starting on pg. 19)

I M P O R T A N T

For high altitude installations above 4500 ft (1372 meters), consult local gas distributor or the authority having jurisdiction for proper de-rating methods.

APPLIANCE DESCRIPTION

TOP VIEW

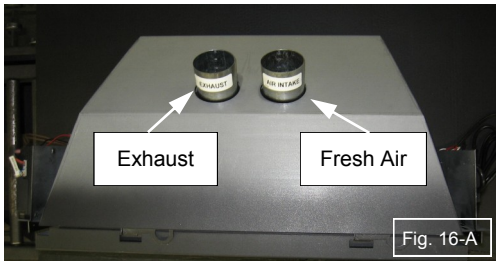

FRONT VIEW



Shown with 27-SKSBS Trim

LEVELING THE 27-DVIE22

Front Level

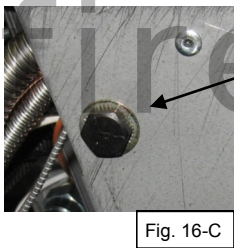

Located slightly in from the front edge of the fireplace is the new leveling feature. Leveling bolts can be installed to enable you to raise the front of the firebox if necessary. If you need higher adjustment you only need to change to a longer bolt. If no rise is required simply leave empty.

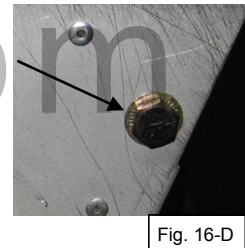

Rear Level

Before placing the appliance into the fireplace, check the hearth of the fireplace to see if it is level with the front of the fireplace. If it is not, measure the depth of the hearth. Loosen the three screws of the leveling “L” bracket at the back of the appliance. Lower it to the measurement obtained and tighten the screws.

ELECTRICAL CONNECTIONS

The 27-DVIE22 comes complete with an adjustable speed fan with 6 levels wired directly to the main control module for your protection against shock hazard.

Do not cut or remove the grounding prong from this plug.

NOTE: This appliance, when installed, must be electrically grounded in accordance with local codes or, in the absence of local codes, with the **National Electrical Code, ANSI / NFPA 70**, or the **Canadian Electrical code, CSA C22.1**.

N O T E

Main On/Off switch must be connected to the surround switch or jumpered and in the “on” position for the remote to operate the fireplace

VENTING INSTRUCTIONS

WARNING: Operation of this heater when not connected to a properly installed and maintained venting system can result in carbon monoxide (CO) poisoning and possible death. The appliance must not be connected to a chimney flue serving a separate solid fuel burning appliance.

C A U T I O N

Only 3" (76mm) double wall aluminum flex liner and approved vent terminals are to be used for this appliance.

APPROVED TERMINATIONS

Manufacturer	Vertical Termination	Termination Adapter
Archgard	999-INS-TK	N/A
Dura Vent	980 - Co-Axial Cap (requires adapter) 991 - Co-Axial High Wind (requires adapter)	923GK (Co-Axial to Co-Linear)
ICC/Excel	IVT - Co-Linear VT - Co-Axial (requires adapter) SVT- Co-Axial (requires adapter)	N/A CTA or CAA (Co-Axial to Co-Linear) CTA or CAA (Co-Axial to Co-Linear)
Ameri-vent	DVC - Co-Axial Cap (requires adapter)	DCAT (Co-Axial to Co-Linear)

A T T E N T I O N

NO OTHER VENTING SYSTEM OR COMPONENTS MAY BE USED. Follow manufacturer instructions for installation of termination.

This appliance is designed for dual 3" (76 mm) double wall aluminum flex liner, running the entire length of the chimney.

The flue length must be a minimum of 10' (3.05 M) and a maximum of 40' (12.2 M)

The exhaust vent restrictor provided with this appliance must only be used by installing it onto the front of the baffle when the vent height is over 18' (5.5 M) if required.

The minimum (chimney) flue size is 4" x 7" (102 mm X 178 mm).

Masonry chimneys may take various contours which the flexible liner will accommodate, however, keep the flexible liner as straight as possible, avoiding unnecessary bending but at all times keep a minimum of 3" (76 mm) inside bend radius.

The Air Intake Flex Liner must be connected to the inlet air collars of the termination cap and the appliance.

The Exhaust Flex Liner must be connected to the exhaust collars of the termination cap and the appliance.

The Air intake and Exhaust connections are marked on the gas appliance. See picture.

DO NOT REVERSE THESE CONNECTIONS

C A U T I O N

To ensure that the venting is not accidentally obstructed or punctured, the damper of the host fireplace must be permanently disabled. Either complete removal of the damper, or welding it in its "open" position. Temporarily disabling the damper is not permissible.

The 27-DVIE22 showing the Fresh Air Intake and Exhaust locations. These connections are labeled.

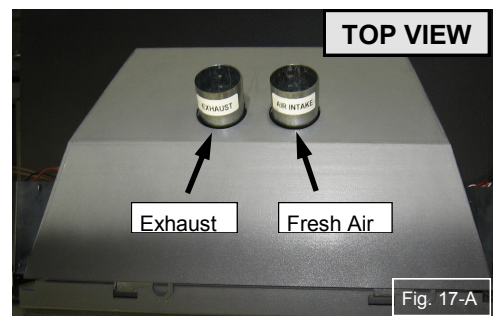

The 27-DVIE22 requires (2) flexible flue liners:

INLET Collar - 3" (76 mm) diameter

OUTLET Collar - 3" (76 mm) diameter

VENTING INSTRUCTIONS 999-INS-TK

Instructions for use with Archgard vertical termination cap. Part # 999-INS-TK

Install the termination cap being sure to provide sufficient space (around and on top) so as not to impede the flow of air, both into and out of the cap. This cap is only to be used for non combustible installations. Do not recess into the top of the chimney.

1. Mark each end of one liner with "Air Intake".
2. Mark each end of the second liner with "Exhaust".
3. Pull the liner through the chimney.
4. Install the flashing.
5. Seal and attach the liner marked "Air Intake" to the vent terminal pipe marked "Air Intake" with the collar clamp provided.
6. Seal and attach the liner marked "Exhaust" to the vent terminal pipe marked "Exhaust" with the collar clamp provided.
7. Seal and attach the end of the flex marked "Air Intake" to the collar marked "Air Intake" on the appliance with the collar clamp provided with the unit.
8. **Install exhaust vent restrictors provided with the unit if required.** Seal and attach the end of the flex marked "Exhaust" to the collar marked "Exhaust" on the appliance.
9. Caulk all joints using a high temperature sealant such as milpac. **DO NOT USE SILICONE SEALANTS. Use of silicon sealants voids the warranty of the pilot assembly.**

NOTE: The vertical termination cap must be sealed to the liner with suitable high temperature sealant, such as milpac and with the hose clamps fasteners provided. **DO NOT USE SILICONE SEALANTS (Use of silicon sealants voids the warranty of the pilot assembly)** The liners must form a complete connection from the appliance flue collars to the vertical termination cap.

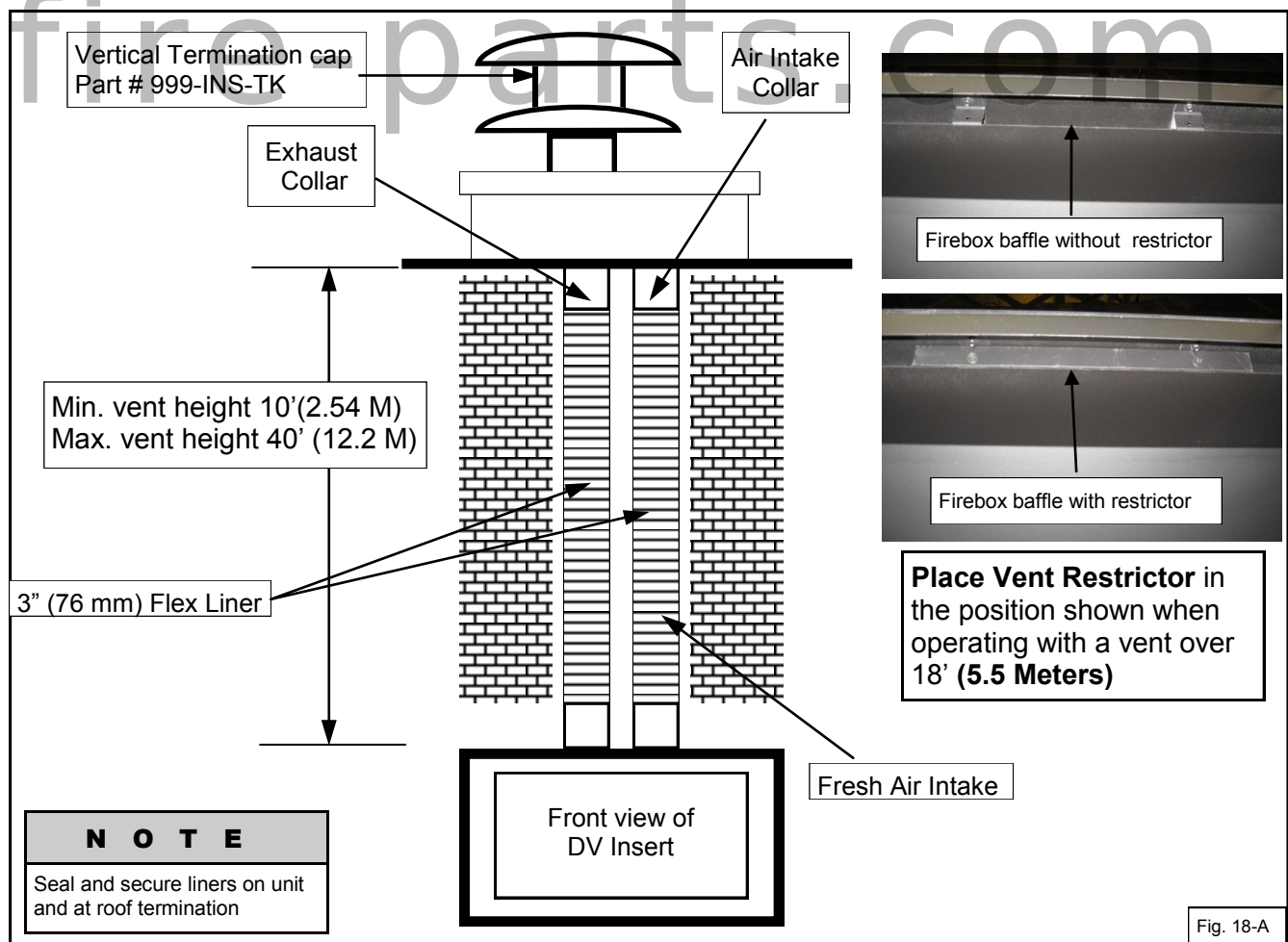

The minimum flue (chimney) size required to run the two 3" (76 mm) is 4" x 7" (100 mm X 178 mm)

SURROUND INSTALLATION

Surround options available are dependent upon the control panel configuration. (See Control Panel Locations regarding configuration.) Shallow surround options are not available on a unit with 'Controls Out' configuration.

Make sure the gas and electrical lines are properly connected to the appliance. Slide the unit into the fireplace and slide the excess flue liner material back onto the chimney. Before the appliance is fully recessed into the fireplace, attach the surround onto the appliance.

Attach the surround to the appliance at the locations shown by lining up the tabs on the surround with the slots on the unit. Make sure the surround drops down and fully engages. Then finish with the wiring connection to the on/off switch on the side of the trim. Now fully "seat" the unit into its final position.

Care must be taken that Trim Panels or Surrounds shall not seal ventilation openings in the fireplace.

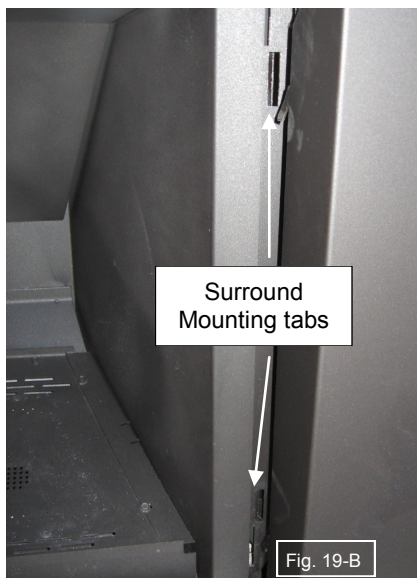

A T T E N T I O N

Main On/Off switch must be connected to the surround switch and in the "on" position for the remote to operate the fireplace



Shown with 27-SKSBS Trim

LOG PLACEMENT

The Archgard pan burner bed and fiber logs are designed to give a realistic fire package, and created to look the same as the day they were originally installed. Care must be given when first installing the logs, and if removed for servicing, as they can be damaged or broken if not handled properly.

After opening the log set package, inspect the logs to ensure that no damage has occurred inside the package. Please report any damage immediately to your Authorized Archgard Dealer.

Gas and vent connection must be made before installing the embers and logs on the pan burner.

N O T E

Improper placement of logs and embers may cause soot accumulation on the internal parts and glass. This is not covered under warranty. Do not use broken or damaged logs.

W A R N I N G

Failure to position the parts in accordance with these diagrams or failure to use only parts specifically approved with this appliance may result in property damage or personal injury.

Locate the embers and logs and place them on their prospective locations. Refer to the pictured instructions on the following pages that will show how to place all six (6) logs. Pins and holes must be aligned with logs and burner.

Locator Pins

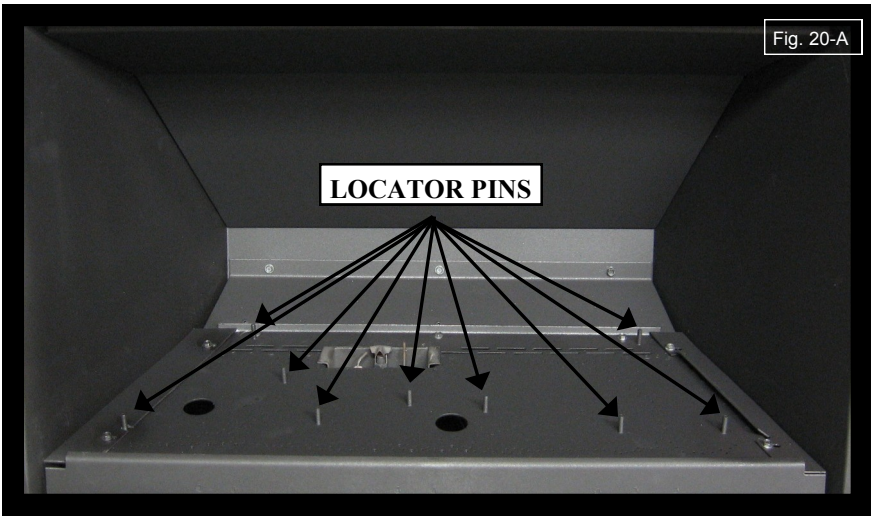

N O T E

Installing the fiber logs in any position other than shown can result in flame impingement causing soot accumulation on the logs, brick liner and ceramic glass viewing area.

LOG PLACEMENT... Continued**L O G # 1**

Locate Log 1 and align the holes in the bottom line up with the two locator pins. Push down firmly onto locator pins.

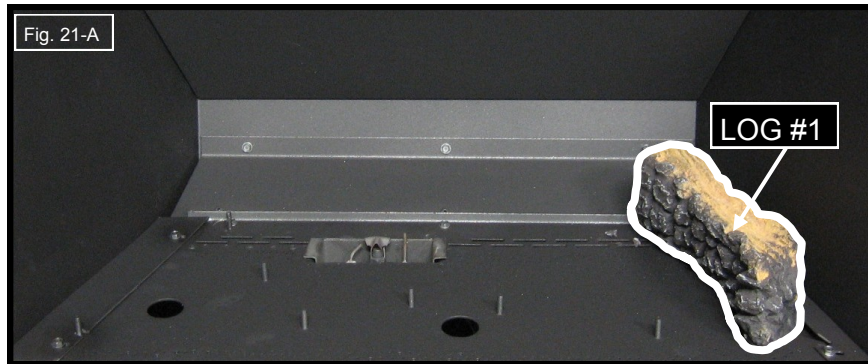
**L O G # 2**

Locate log #2 using the locator pin on the burner for the left side. Sit the right side of the log into the notch of log #1 (as shown in inset)

**L O G # 3**

Locate Log 3 and align the two holes in the log with the two locator pins on the left of the burner. Push down onto locator pins as shown.



LOG PLACEMENT... Continued**L O G # 4**

Locate Log #4 and align the two holes in the log with the two locator pins in the center of the burner. Push down onto locator pins as shown.

**L O G # 5**

Locate Log #5 and align the hole in the bottom with the locator pin in the burner. Place the other end of the log in the locator pin of log #2.

**L O G # 6**

Locate Log 6 and align the hole in the bottom with the locator pin in the burner. Lay the log back top rest against log #2 and log #4



LOG PLACEMENT... Continued

N O T E

Logs #1, #3 and #4 have been crafted to allow airflow from under the logs. **DO NOT** crush the bottom of the logs to make these sit flush with the top of the burner. Care must also be taken to not completely block the front of the logs with embers.



DO NOT block under log air paths.

S T E P # 7

Place black embers around logs as shown , do not completely block the holes in the burner.



Black Embers

COMPLETE LOG SET

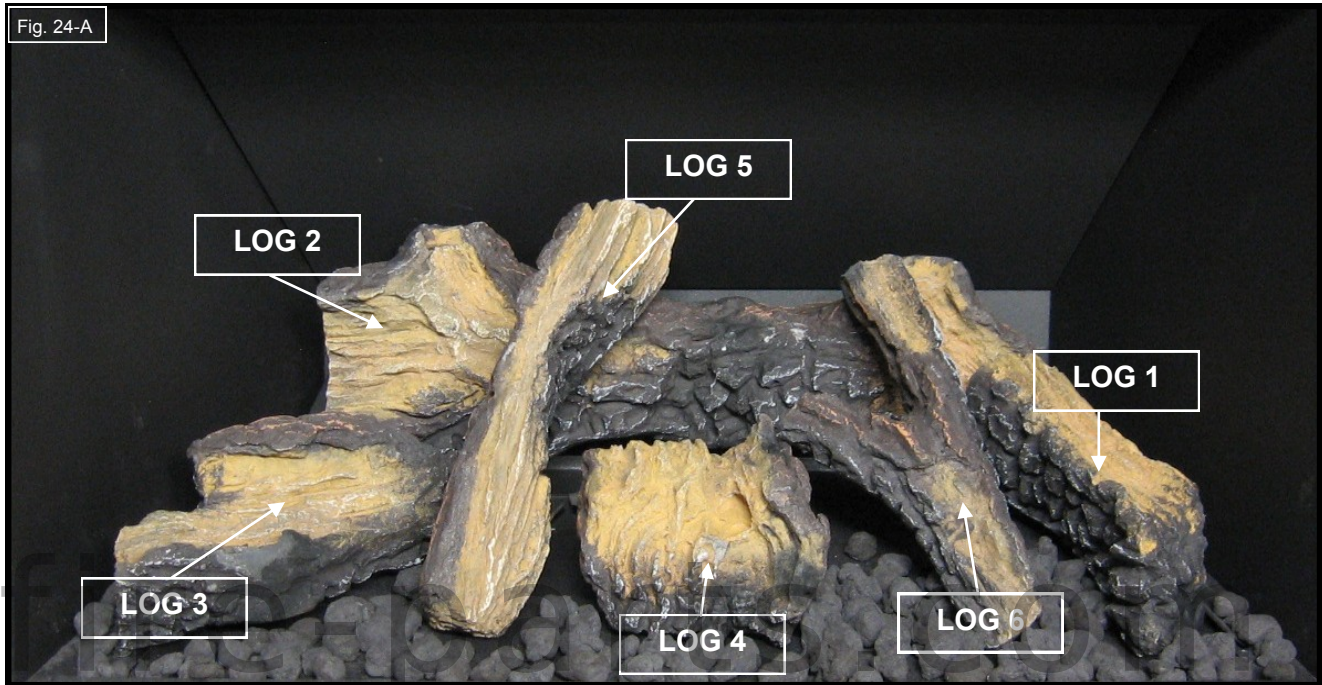

Item #	Item Description	Qty	Unit
310-6270	Complete Log Set	1	EA
310-6270-1	Log 1 (Right Side)	1	EA
310-6270-2	Log 2 (Rear)	1	EA
310-6270-3	Log 3 Left Side)	1	EA
310-6270-4	Log 4 (Center Front)	1	EA
310-6222-6	Log 5 (Center Left)	1	EA
310-6222-5	Log 6 (Center Right)	1	EA
310-0020	Black Embers (2 cup bag)	1	EA

GLASS DOOR REMOVAL AND REPLACEMENT**C A U T I O N**

Do not attempt to remove the glass door when the appliance is hot.

1. Just above the door frame reach in and pull the two finger rings forward (25-A).
2. Pull and lift the finger rings to detach from the door frame (25-B).
3. Pull the door forward until the bottom catches release.
4. Lift door up and away.
5. To replace the door line up the two bottom catches with the notches on the fireplace. While pushing evenly on the bottom of the door lift up on the top of the door until it engages.
6. Push down on the top of the door to ensure the door is seated all the way down on the catches.
7. Pull the finger rings out and down to engage in the slots on the top of the door frame.
8. Push the finger rings back.



Fig. 25-A



Fig. 25-B

W A R N I N G

Do not operate appliance with the glass front cracked or broken. Replacement of the glass should be done by a licensed or qualified service person.

**IF YOUR GLASS BREAKS**

In the event your glass cracks or breaks, Archgard recommends that a complete new door assembly be ordered to replace the original door.

- Remove door as per the instructions above.
- Replace with new door assembly.

N O T E

The new door will emit some odor/fumes when the appliance is re-lit. This will quickly dissipate after gasket material within the door has cured.

W A R N I N G

Do not substitute glazing materials. Use ARCHGARD certified replacement parts

FINAL INSTALLATION CHECK

Each Archgard Gas Fireplace is checked and tested at the factory prior to being packaged and shipped to our dealers and finally installed in your home. Archgard recommends that before leaving this unit with the customer, the installer must ensure that the appliance is firing correctly and that the electrical system is in working order. **This will include:**

1. Perform leak tests of supply line, gas control valve, supply line from gas control valve and pilot assembly.
2. Clocking the appliance to ensure the correct firing rate (see page 6 of this manual).
3. If required, adjusting the primary air to burner to ensure that the flame does not carbon or soot.
4. Check for proper operation including correct drafting.
5. The fireplace should be turned ON to ensure that the fan is working correctly. After the system has been checked and confirmed that the fan is in working order, refer to the instructions for FIRST FIRE located in this manual.

As a reminder, a TAG is attached to all of our gas fireplaces. This TAG is located at the gas control valve. See below.

Fig. 26-A

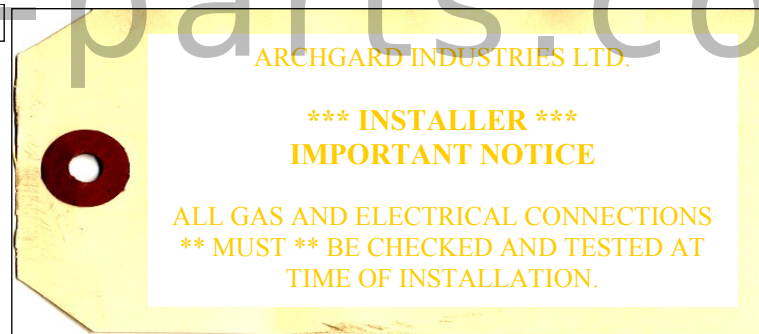

N O T E

Any alteration to our product that causes carbon or soot deposits that results in any damage or requires cleaning is not the responsibility of the manufacturer.

INITIAL OPERATION

1. Check that the appliance is properly vented and connected to the gas supply.
2. Check that the logs and branches are properly placed.
3. Check that all external parts, such as door and faceplate are properly attached and fastened.
4. Do not operate this appliance with broken, cracked glass doors or without the door (s) in its correct (and latched) position. Do not abuse the glass by either striking or slamming shut.
5. Check that there are no fingerprints left on glass panels, as high temperature can bake these prints on permanently.

FIRST FIRE**A T T E N T I O N**

When operated for the first few times, the appliance will emit some odor and fumes. This is due to the heat evaporating the oils and solvents used in the production of the fireplace. Close off the room to the rest of the house and open all windows. Keep the room well ventilated, as smoke alarm may sound. Run the appliance for at least 6 hours at maximum setting with blower set to "OFF" to allow paint to cure (after the installer has checked to ensure the fan is operational). Smoke and fumes caused by the curing process may cause discomfort to some individuals.

LIGHTING INSTRUCTIONS - CAUTION**W A R N I N G**

If you do not follow these instructions exactly, a fire or explosion may result causing property damage, personal injury or loss of life. Do not operate the appliance with the glass front removed, cracked or broken. Replacement of broken glass should be done by a licensed or qualified service person.

N O T E

This appliance requires fresh air for safe operation and must be installed so there are adequate provisions for combustion and ventilation air.

Do not store or use gasoline or other flammable vapors and liquids in the vicinity of this or any other appliance.

WHAT TO DO IF YOU SMELL GAS:

- * Do not try to light any appliance.
- * Do not touch any electrical switch; do not use any phone in your building.
- * Immediately call your gas supplier from a neighbor's phone. Follow the gas supplier's instructions.
- * If you cannot reach your gas supplier, call the fire department.

Installation and service must be performed by a qualified installer, service agency or the gas supplier.

1. **BEFORE LIGHTING**, smell all around the appliance area for gas. Be sure to smell next to the floor, because some gasses are heavier than air and will settle on the floor.
2. **IF YOU SMELL GAS**, follow the instructions as listed directly above or as shown on the front cover of this manual.
3. Do not use this appliance if any part has been under water. Immediately call a qualified service technician to inspect the appliance and to replace any part of the control system and any gas control which has been under water.
4. This appliance is equipped with an ignition device which automatically lights the pilot and main burner. The pilot and burner light automatically with the hand held remote or with the switch on the side of the surround if it is activated.

LIGHTING INSTRUCTIONS ON RATING PLATE

FOR YOUR SAFETY READ BEFORE LIGHTING Pour votre sécurité Veuillez lire avant d'allumer

WARNING: If you do not follow these instructions exactly, a fire or explosion may result causing property damage, personal injury or loss of life.

ATTENTION: Si vous ne suivez pas ces instructions à la lettre, un feu d'une explosion entraînant des dommages matériels, des blessures ou la perte de la vie.

- | | |
|--|---|
| <p>A. This appliance has a pilot which must be lighted by a spark ignitor. When lighting the pilot follow these instructions exactly.</p> <p>B. BEFORE LIGHTING smell all around the appliance area for gas. Be sure to smell next to the floor because some gas is heavier than air and will settle on the floor.</p> <p>WHAT TO DO IF YOU SMELL GAS</p> <ul style="list-style-type: none"> • Do not try to light any appliance. • Do not touch any electrical switch; do not use any phone in your building. • Immediately call your gas supplier from a neighbor's phone. Follow the gas supplier's instructions. If you cannot reach your gas supplier, call the fire department. <p>C. Do not use this appliance if any part has been under water. Immediately call a qualified service technician to inspect the appliance and to replace any part of the control system and any gas control which has been under water.</p> | <p>A. Cet appareil possède une veilleuse qui doit être éclairée par une bougie d'allumage. En allumant le pilote suivez ces instructions à la lettre.</p> <p>B. AVANT D'ALLUMER odeur tout autour de l'appareil pour le gaz. Assurez-vous de sentir à côté du plancher, car certains gaz sont plus lourds que l'air et se déposent sur le sol.</p> <p>QUE FAIRE SI VOUS UNE ODEUR DE GAZ</p> <ul style="list-style-type: none"> • Ne pas tenter d'allumer l'appareil. • Ne touchez à aucun interrupteur électrique; ne pas utiliser le téléphone dans votre immeuble. • Appelez immédiatement votre fournisseur de gaz de téléphone d'un voisin. Suivez les instructions du fournisseur de gaz. Si vous ne pouvez pas joindre votre fournisseur de gaz, appelez les pompiers. <p>C. Ne pas utiliser cet appareil si une partie a été sous l'eau. Appeler immédiatement un technicien qualifié pour inspecter l'appareil et remplacer toute pièce du système de contrôle et de commande du gaz qui a été sous l'eau.</p> |
|--|---|

LIGHTING INSTRUCTIONS INSTRUCTIONS D'ALLUMAGE

STOP! Read the safety information above on this label.

1. This appliance is equipped with an ignition device which automatically lights the pilot. Do not try to light the pilot by hand
 2. Set the remote switch to "OFF"
 3. Turn on the electric power to the appliance.
 4. Open the Gas isolation valve
 5. Turn remote to the "ON" position
- If the pilot and burner will not stay lit after several tries, turn the remote to the "OFF" and check the lighting instructions in the manual or call your service technician or gas supplier.

STOP! Lire les consignes de sécurité ci-dessus sur cette étiquette.

1. Cet appareil est équipé d'un dispositif d'allumage qui allume automatiquement le pilote. Ne pas tenter d'allumer le pilote à la main
 2. Réglez le commutateur à distance sur "OFF"
 3. Tournez sur la puissance électrique de l'appareil.
 4. Ouvrez la vanne d'isolement de gaz
 5. Tournez à distance à la position «ON»
- Si le pilote et le brûleur ne reste pas allumée après several, tourner la télécommande sur le "OFF" et vérifiez les instructions dans le manuel d'éclairage ou appelez votre technicien ou votre fournisseur de gaz.

TO TURN OFF GAS TO APPLIANCE INSTRUCTIONS D'ALLUMAGE

- | | |
|--|---|
| <ol style="list-style-type: none"> 1. Set the remote switch to "OFF". 2. Turn off all electric power to the appliance if service is to be performed. 3. Close the gas isolation valve | <ol style="list-style-type: none"> 1. Réglez le commutateur à distance sur "OFF". 2. Coupez l'alimentation électrique de l'appareil si le service doit être exécuté. 3. Fermez la vanne d'isolement de gaz |
|--|---|

REMOTE CONTROL SETUP AND OPERATION

I M P O R T A N T

The Proflame II Transmitter is an integrated part of the Proflame II System, which consists of these elements:

- Proflame II Transmitter, to be used in conjunction with:
- Integrated Fireplace Control (Proflame II IFC)



The Proflame II Transmitter provides for controlling the following hearth appliance functions:

1. Main Burner ON/OFF
2. Main Burner flame modulation (6 levels)
3. Choice of standing or intermittent pilot (CPI/IPI)
4. Thermostat and SMART thermostat function
5. Comfort fan speed modulation (6 levels)

The Proflame Transmitter uses a streamline design with a simple button layout and informative LCD display. A Mode Key is provided to index between the features and a Thermostat Key is used for on/off or to index through the thermostat function. Additionally a Key Lock function is provided.

A T T E N T I O N

- TURN "OFF" THE MAIN GAS SUPPLY DURING INSTALLATION OR MAINTENANCE OF THE RECEIVER DEVICE
- TURN "OFF" MAIN GAS SUPPLY TO THE APPLIANCE PRIOR TO REMOVING OR REINSERTING THE BATTERIES
- IN CASE OF REMOTE CONTROL MALFUNCTION TURN OFF THE IFC DEVICE USING THE 'ON/OFF' MAIN SWITCH
- FOR INSTALLATION/MAINTENANCE SWITCH OFF THE IFC DEVICE REMOVE BY REMOVING MAIN POWER SUPPLY PLUG

TECHNICAL DATA - REMOTE CONTROL

Supply Voltage	4.5 V (three (3) 1.5V AAA batteries)
Ambient temperature ratings	0 - 50 C (32 - 122 F)
Radio frequency	315 MHz

REMOTE CONTROL SETUP AND OPERATION

HANDHELD REMOTE DISPLAY

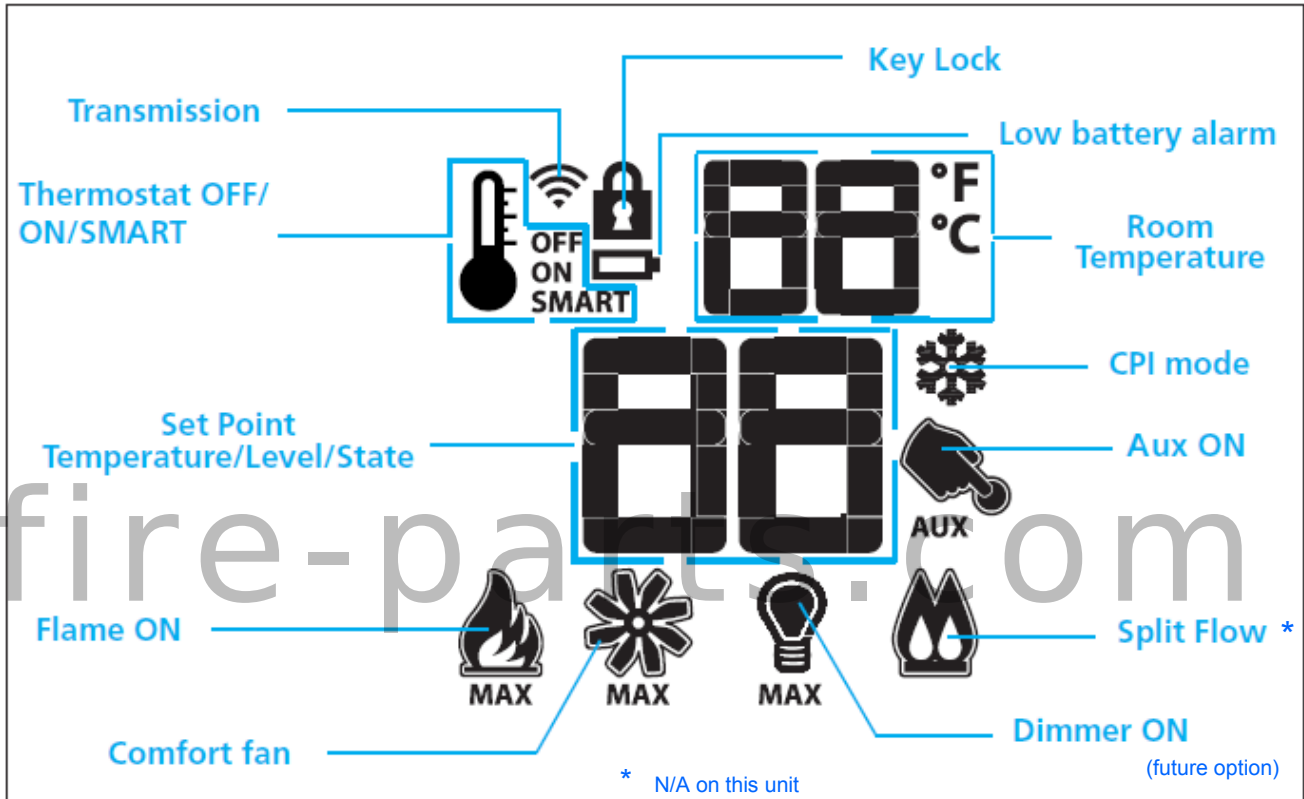

Fig. 30-A

W A R N I N G

THE TRANSMITTER AND RECEIVER ARE RADIO FREQUENCY DEVICES. PLACING THE TRANSMITTER IN OR NEAR METAL ENCLOSURES MAY REDUCE THE SIGNAL RANGE

OPTIONAL WALL MOUNT REMOTE

All the same functions of the Handheld Remote with the convenience of always knowing where the remote is.

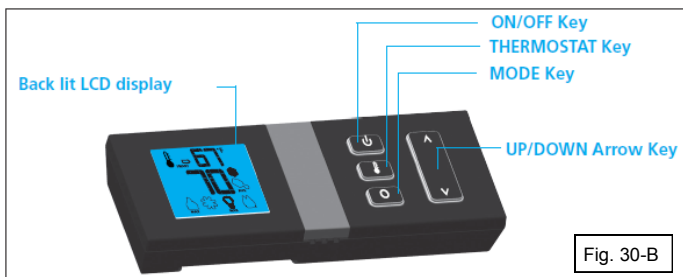

Fig. 30-B

Simple Installation

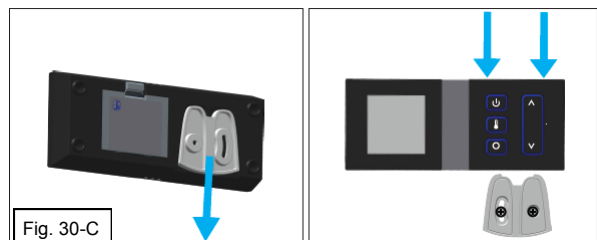

Fig. 30-C

REMOTE CONTROL SETUP AND OPERATION

INITIALIZING THE SYSTEM FOR HANDHELD REMOTE OPERATION

1. Connect IFC Control Module to AC power supply. A single “beep” will indicate the presence of power. **NOTE: This will initiate Pilot Start-up in Manual Mode. The pilot will spark repeatedly and ignite if gas has been supplied to the unit if the main power switch is in the “ON” position.**
2. Install three (3) AAA batteries into the Handheld Remote battery bay.
3. Press red SW1 button until the IFC module beeps three (3) times and/or the amber LED illuminates indicating the module is ready to synchronize with the remote.
4. Within ten (10) seconds push the ON/OFF button on the handheld remote to lock in code to the module. The IFC module will “beep” four (4) times to indicate a successful link.
5. Press the ON/OFF button to turn off the pilot. This indicates the handheld remote is now in control of the IFC Control Module.
6. Install the provided four (4) AA batteries into battery back up holder.

INITIALIZING THE SYSTEM FOR MANUAL OPERATION

1. Connect IFC Control Module to AC power supply. A single “beep” will indicate the presence of power. **NOTE: This will initiate Pilot Start-up in Manual Mode. The pilot will spark repeatedly and ignite if gas has been supplied to the unit if the main power switch is in the “ON” position.**
2. The ON/OFF rocker switch on the surround must be connected to the leads coming from the module
3. Press red SW1 button until the IFC module beeps three (3) times and/or the amber LED illuminates indicating the module is ready to synchronize with the remote.
4. Within ten (10) seconds push the red SW1 button on the IFC again to lock in the manual mode. The IFC module will “beep” four (4) times to indicate a successful link. In this mode the fireplace will only turn ON/OFF with no optional functions
5. The rocker switch on the side of the trim will now operation the fireplace.
6. Install the provided four (4) AA batteries into battery back up holder.



Fig. 31-A

Battery Compartment

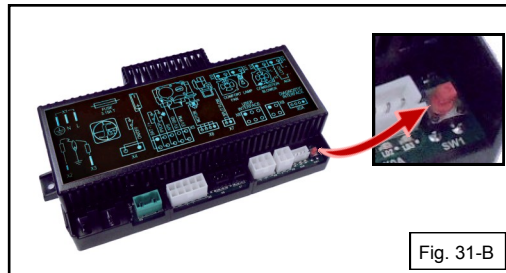

Fig. 31-B

Proflame II IFC Module

TURN “ON” THE APPLIANCE

With the system OFF, press the ON/OFF Key on the Transmitter. The Transmitter display will show other active icons on the screen. At the same time the Receiver will activate the appliance. A single “beep” from the receiver will confirm reception of the command.

TURN “OFF” THE APPLIANCE

With the system OFF, press the ON/OFF Key on the Transmitter. The Transmitter display will show other active icons on the screen. At the same time the Receiver will activate the appliance. A single “beep” from the receiver will confirm reception of the command.

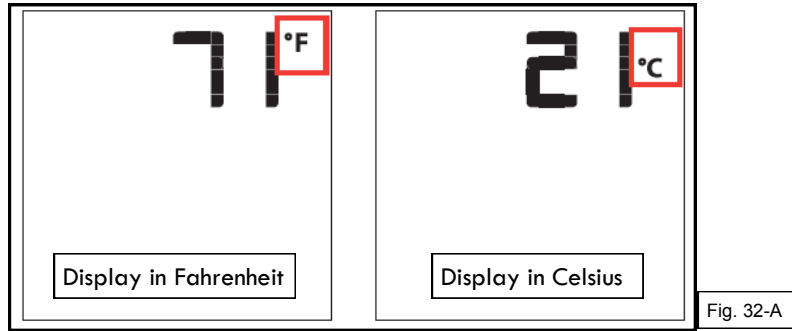

Fig. 31-C

REMOTE CONTROL SETUP AND OPERATION

TEMPERATURE INDICATION DISPLAY

With the system in the "OFF" position, press the Thermostat Key and the Mode Key at the same time to switch between Fahrenheit (F) or Celsius (C). Verify on the LCD screen the correct designation is visible



VARIABLE FLAME CONTROL

This function is disabled when in SMART Thermostat Mode

The Proflame IFC has six (6) flame levels. With the system "ON" and the flame at maximum in the appliance, pressing the Down Arrow Key once will reduce the flame height by one step. Repeat to lower the flame till "OFF". The UP Arrow Key will increase the flame height each time it is pressed. If the UP Arrow Key is pressed while the system is on but the flame is off, the flame will activate in the high setting. A single "beep" will confirm reception of the command

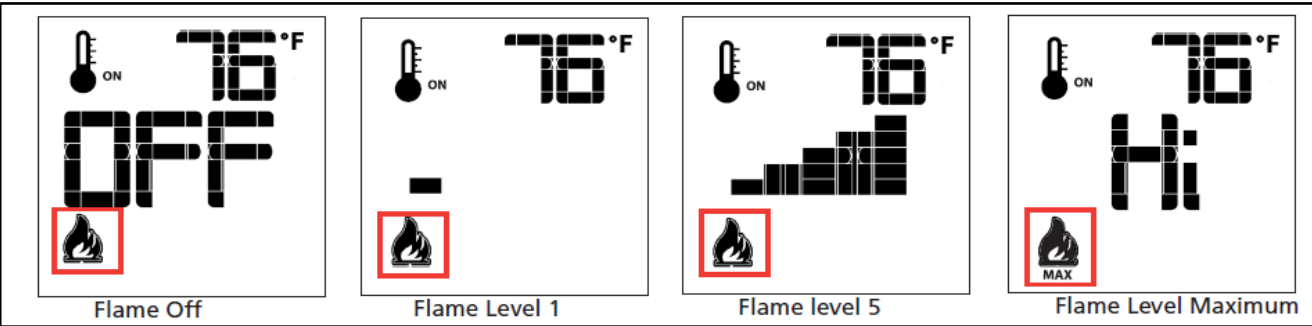

Fig. 32-B

FAN SPEED CONTROL

If the appliance is equipped with a hot air circulating fan, the speed of the fan can be controlled by the Proflame system. The fan speed can be adjusted through six (6) speeds. To activate this function use the Mode Key to index to the fan control icon. Use the Up/Down Arrow Keys to turn on, off or adjust the fan speed. A single "beep" will confirm reception of the command.

In manual mode the fan will activate immediately upon burner ignition. Adjust the fan speed to personal preference. Blower will shut off when the burner is extinguished.

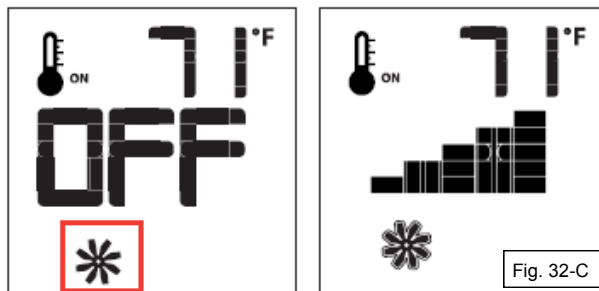

Fig. 32-C

REMOTE CONTROL SETUP AND OPERATION

ROOM THERMOSTAT (TRANSMITTER OPERATION)

The Remote Control can operate as a room thermostat. The thermostat can be set to a desired temperature to control the comfort level in a room.

- To activate this function:
- Press the Thermostat Key. The LCD display on the remote will change to show that the room thermostat is “ON” and the set temperature is now active.
- To adjust the temperature, press the Up/Down Arrow Keys until the desired temperature is displayed.

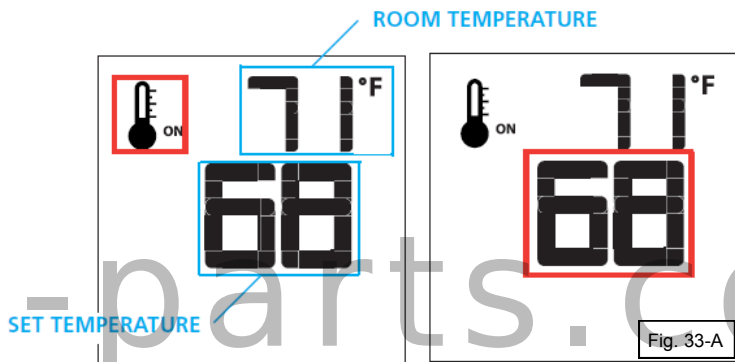

SMART THERMOSTAT (TRANSMITTER OPERATION)

The Smart Thermostat function adjusts the flame height automatically in accordance to the difference between the set point and the actual room temperature. As the room temperature approaches the set point, the Smart Function will modulate the flame down.

To activate this function:

- Press the Thermostat Key until the word “SMART” appears to the right of the temperature bulb graphic.
- To adjust the set temperature, press the Up/Down Arrow Keys until the desired set temperature is displayed.

N O T E

When the fireplace is started in Smart Thermostat mode:

1. The fan will automatically activate 5min after ignition and shut down 12min after fire is turned off.
2. Manual Flame height adjustment is disabled

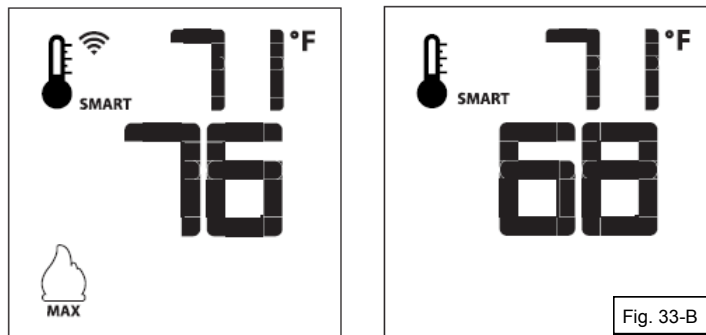

REMOTE CONTROL SETUP AND OPERATION

Continuous Pilot/Intermittent Pilot (CPI/IPI) selection

With the system in "OFF" position press the Mode Key to index to the CPI mode icon. Pressing the UP Arrow Key will activate the Continuous Pilot Ignition mode (CPI). Pressing the Down Arrow Key will return to IPI. A single "beep" will confirm the reception of the command.

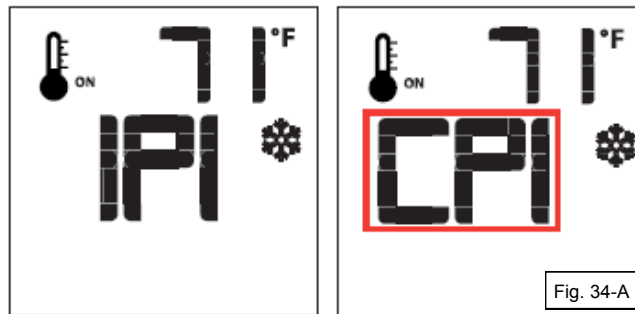

Fig. 34-A

NOTE

This system is shipped from the factory with a CPI/IPI Jumper that enables the ability to switch between CPI/IPI with the remote.

To disable the Continuous Pilot selection ability via the remote, cut one of the wires (blue or white) shown in the picture and cap them off to prevent shorting. Once this connection is severed, the appliance will not switch to standing pilot even if the remote shows a CPI mode.

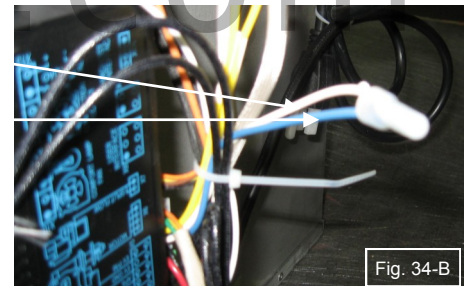

Fig. 34-B

AUTOMATIC SAFETY SHUT-OFF

This system will execute an automatic turn OFF command after a 24hr continuous pilot flame ignition. This allows the system to verify correct safety functions.

DIAGNOSTIC INDICATIONS INFORMATION

LOW BATTERY CONDITION (Less than 4V):

- | | |
|------------------------|--|
| Remote Control | - Battery Icon will appear on LCD remote control display. Replace batteries. |
| Battery Back-up | - Red LED indicator will enter a (1) blink sequence. IFC Module will emit a double-beep when it receives an ON/OFF command from the hand held remote. Replace batteries. |

Pilot Flame Error Condition:

- Red LED Indicator will commence a (2) blink sequence. Contact your dealer if this occurs.

System Lock Out Condition:

- Red LED Indicator will commence a (3) blink sequence. Make sure your gas is turned on.
- Make sure pilot sensor is not shorted out.
- Follow reset information above if the module goes into a Lock Out state.

REMOTE CONTROL SETUP AND OPERATION

KEY LOCK

This function will lock the keys to avoid unsupervised operation.

- To activate this function, press the MODE and UP Keys at the same time.
- To deactivate this function, press the MODE and UP Keys at the same time.

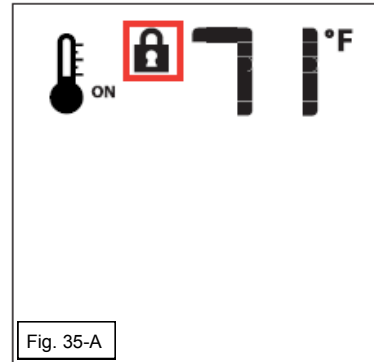

Fig. 35-A

LOW BATTERY POWER DETECTION (Less than 4V)

Transmitter

The life span of the remote control batteries depend on various factors:

- Quality of the batteries used.
- The number of ignitions of the appliance.
- The number of changes to the room temperature set point, etc.

When the Transmitter batteries are low, a Battery Icon will appear on the LCD display of the Transmitter before all battery power is lost. When the batteries are replaced this Icon will disappear.

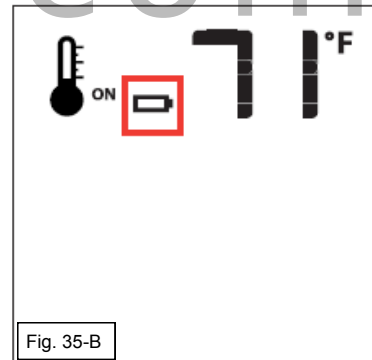

Fig. 35-B

BACKUP BATTERY PACK (used when electrical power is interrupted):

- Red LED indicator on the IFC Module will enter a (1) blink sequence.
- Backup batteries lifespan depends on various factors including battery quality, number of ignitions, changes to room thermostat set point, etc. When batteries are low, a double beep will be emitted from the IFC control module when it receives an ON/OFF command from the remote control.
- This is an alert for a low battery condition of the backup batteries and after this double-beep warning, no commands will be accepted until batteries are replaced.
- When batteries are replaced a beep will be emitted from IFC control module as soon as powered.

SIT INTERMITTENT IGNITION SEQUENCE

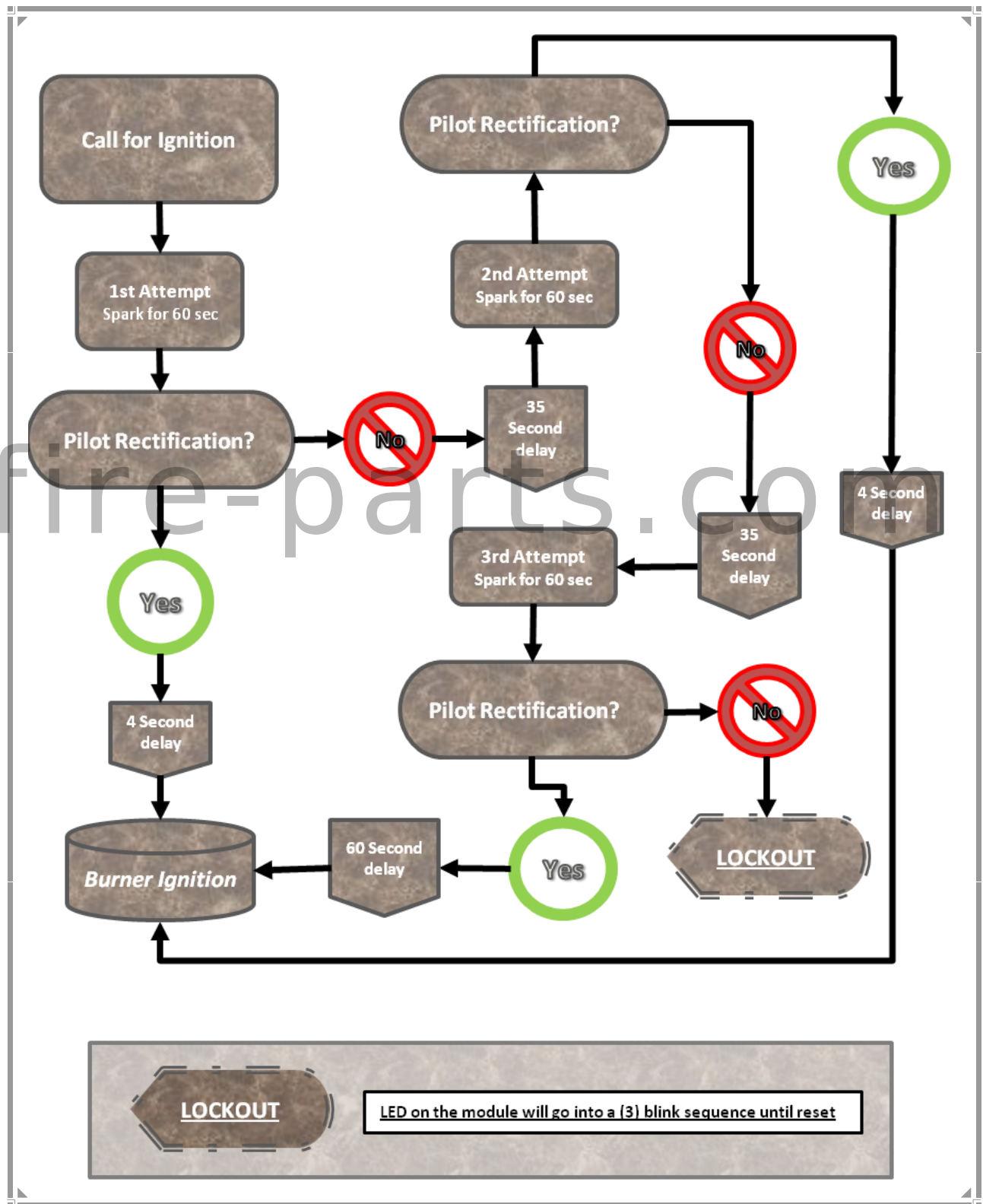

Fig. 36-A

MAINTENANCE**C A U T I O N**

Do not conduct maintenance on the appliance while it is operating or while it is still hot.

CLEANING THE APPLIANCE

The exterior painted surfaces, glass and gold trims may be cleaned with a soft, non-abrasive cloth and water or a suitable, mild, non-abrasive cleaner. The use of abrasive cleaners will damage the glass which may cause an unsafe situation and void the warranty.

Regularly:

- Frequent cleaning of the ceramic glass is required. Archgard recommends using a good quality “gas fireplace” glass cleaner that is available at any hearth retail location. **DO NOT CLEAN WHILE HOT.**
- Clean and remove any lint accumulations or debris from the combustion and convection air passage ways.
- Visually check the height and color of the burner and pilot flames (as shown on pg #39)

Every 2 to 3 months:

- Remove the glass door and clean the inside of the glass with a good quality “gas fireplace” glass cleaner. **DO NOT CLEAN WHILE HOT.**
- Carefully remove the media and gently brush off any loose carbon deposits. This job is best done outside the house. **Do not wash logs with any liquid.** While the logs are removed, check that all burner openings are not obstructed and it is recommended you use a vacuum cleaner to clean off any dust or lint.
- After cleaning, the media must be replaced as per the instructions in this manual.

Once a year, have a qualified service technician:

- Completely inspect the appliance and the venting system, if the vent pipe or seal is found to be defective, replace and or reseal (follow the instructions found in the venting instructions section). Verify proper operation after servicing.
- Clean and remove any lint accumulations or debris in the firebox, on the burners, on the pilot, at the primary air opening, on the convection air blower and in any combustion and convection air passageways.
- Check the safety system of the gas valve and the appliance.

S A F E T Y N O T E

The appliance area must be kept clear and free from combustible materials, gasoline and other flammable vapors and liquids.

W A R N I N G

All parts removed or disturbed, including guards and grills, must be properly replaced after maintenance. Service and repair must be conducted by a qualified service person. If these instructions are not followed, a fire or explosion may result, causing property damage, personal injury or loss of life.

SERVICING UNDER WARRANTY

Before servicing, read the terms and conditions of the Archgard warranty at the back of the manual. Contact the authorized Archgard dealer where you purchased the appliance from and provide them with details of the problem, along with the initial installation information (from the front of this manual).

W A R N I N G

Servicing of this appliance must be conducted by a **qualified service technician**. Improper servicing, adjustment or alteration of this appliance may cause property damage, personal injury or loss of life. All servicing should be conducted with the appliance cold. All replacement parts must be authorized by Archgard for suitability.

ADJUSTING PRIMARY AIR

NOTE: Fig. 38-A is an *example* of what a correct or incorrect flame pattern looks like. It is not a true representation of what the 27-DVIE22 will look like in your home environment. The air shutter can be adjusted from the front of the unit while in operation. All adjustments should be made after 20 minutes of operation.

1. Locate the Robertson screw below the glass door and left of center.
2. Turn the screw clockwise to give more air (less yellow flame). Turn the screw counter clockwise to give less air (more yellow flame).

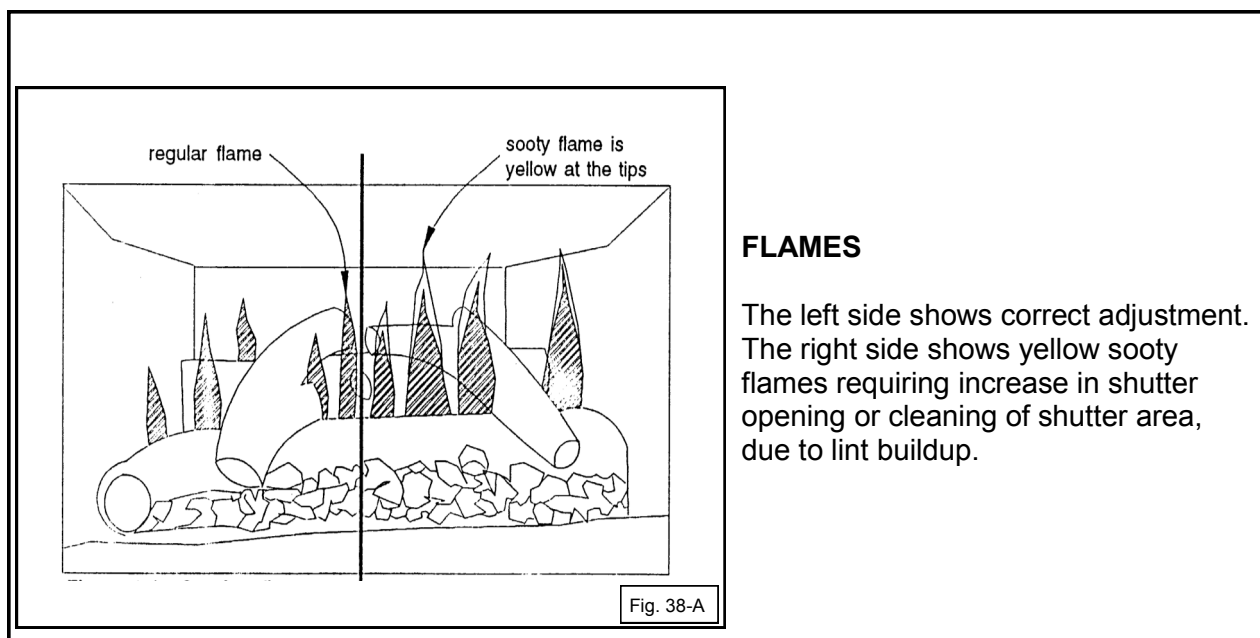

CHECKING INLET AND OUTLET GAS PRESSURE

1. Remove the surround.
2. The pressure test taps are located on the valve. The taps are located in the gas valve front face. The inlet is marked 'IN' and the outlet is marked 'OUT'. See Fig.39-A
3. Loosen the set screw inside the tap with a screwdriver.
4. Connect a 1/4" (6 mm) rubber tube to the tap post and a manometer.
5. Verify that the readings obtained are within specs (as shown on the appliance rating plate)
6. Be sure to tighten the set screw inside the tap after you finish taking pressure readings.
7. Check for leaks.

GAS VALVE

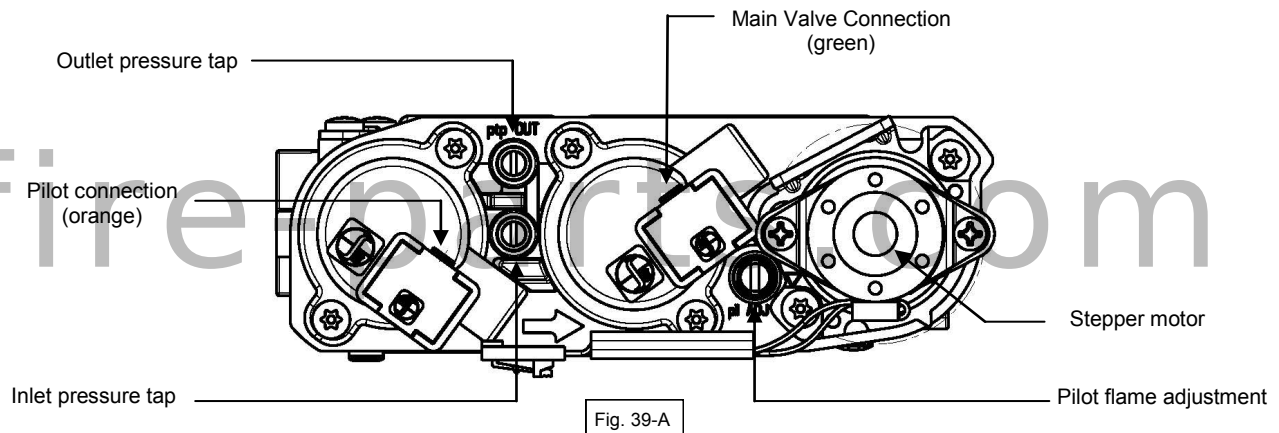

CHECKING AND ADJUSTING PILOT

The pilot flame should have the characteristic as shown in the illustration to the right.

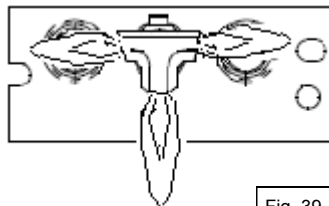

The flame should not have yellow tips but should engulf the flame sensor and spark electrode. It can be adjusted by turning the screw marked "pilot" on the control valve.

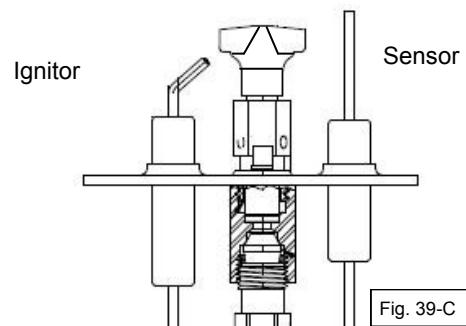

REPLACING COMFORT BLOWER**C A U T I O N**

Label all wires prior to disconnection when servicing controls. Wiring errors can cause improper and dangerous operation. Verify proper operation after servicing.

This appliance, when installed, must be electrically grounded in accordance with local codes or, in the absence of local codes, with the **National Electrical Code, ANSI/NFPA 70**, or the **Canadian Electrical code, CSA C22.1**.

N O T E

- **Make sure the gas to the appliance has been shut off.**
- **Ensure that the main power and breaker system is turned off before removing the fan.**
- **Make sure the fireplace has been turned off and is cool to the touch.**
- **Mark all wires to be removed for proper reassembly.**

I M P O R T A N T

Wiring errors cause improper and dangerous operation.

The convection fan can be accessed either through the front or through the back of the insert.

TO ACCESS FROM THE FRONT

1. Remove the glass door. Follow GLASS DOOR REMOVAL instructions within this manual.
2. Remove the BURNER MEDIA.
3. Remove the pan burner. Follow instructions for CHANGING MAIN BURNER ORIFICE within the conversion section of this manual.
4. Remove the access cover (section set at 45 degree angle) of the firebox by removing the 1/4 " hex head screws.
5. Remove the four nuts holding the fan in place.
6. Disconnect the wires.
7. Mark all wires to be removed for proper reassembly.
8. Install new fan in reverse order.
9. Reverse these steps after new fan is installed & tested.

TO ACCESS FROM THE BACK

1. Remove the surround by lifting up and forward.
2. Disconnect the gas line.
3. Disconnect the intake and exhaust liners
4. Remove the insert from the fireplace.
5. Remove 1/4" hex head screws and the cover plate at the back of the insert
6. Remove the 1/4" hex head screws holding the fan bracket.
7. Disconnect the wires.
8. Remove the 4 nuts holding the fan to the bracket.
9. Replace the fan with the new fan.
10. Reassemble in the reverse order. Making sure to re-seal the venting.

WIRING SCHEMATICS

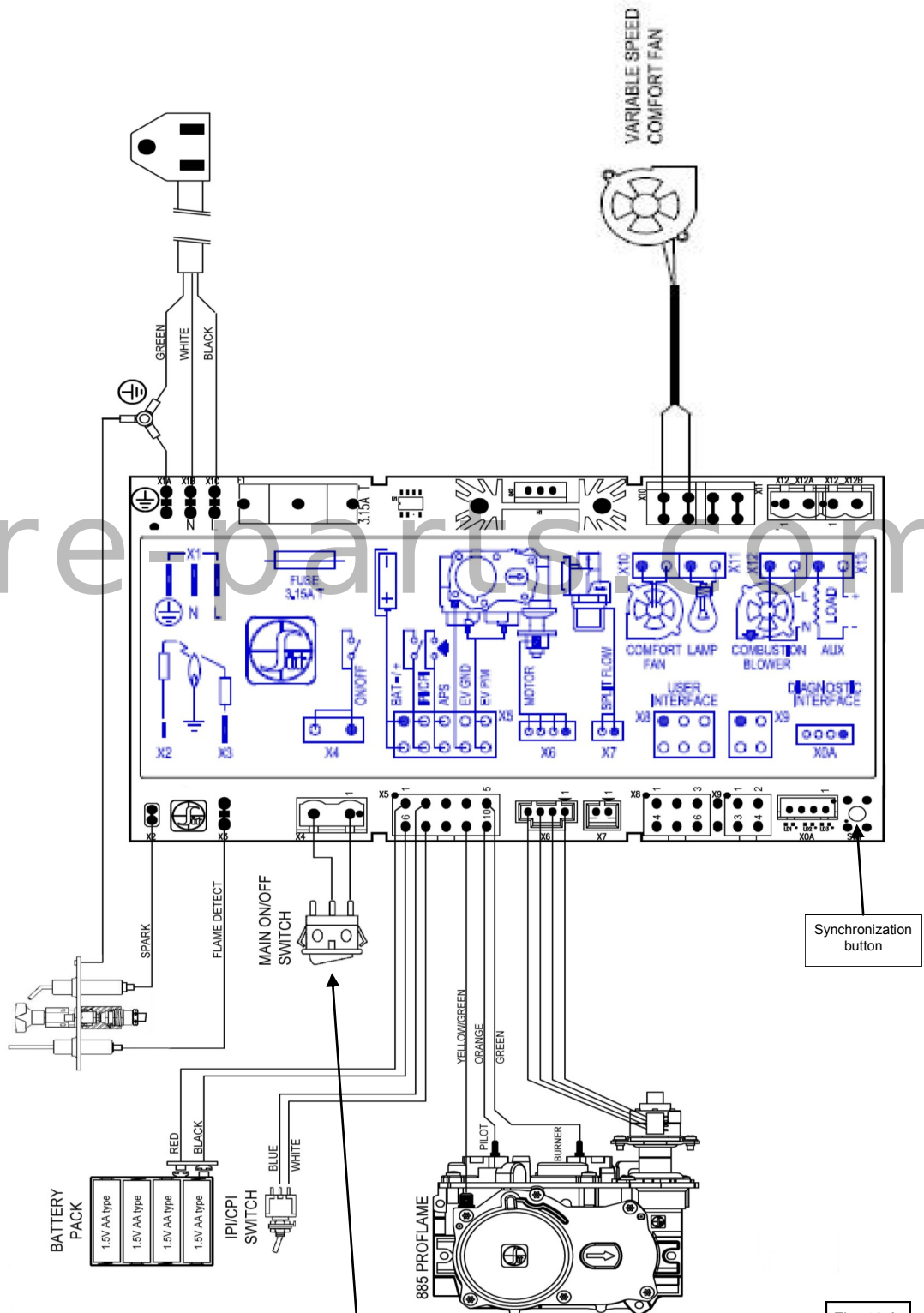

Main On/Off switch must be connected to the surround switch and in the "on" position for the remote to operate the fireplace

Fig. 41-A

ARCHGARD LIMITED WARRANTY

This Limited Warranty is made by ARCHGARD INDUSTRIES LTD., hereinafter referred to as "Archgard". Archgard warrants to the original purchaser of an Archgard gas burning fireplace (s) that the product will be free of defects in materials and workmanship under normal use and service, for a "lifetime".

INCLUSIONS: "LIFETIME LIMITED WARRANTY"

- ❖ All heat exchangers, combustion chamber, burner tubes and pans.
- ❖ Ceramic Fiber Logs and Ceramic Brick Panels against splitting or cracking from heat exposure.
- ❖ Ceramic Glass against thermal breakage.
- ❖ NOTE: Discoloration and some minor movement of certain parts are normal and are not a defect and therefore, not covered under warranty.

The above will be covered "parts & labor" to the original purchaser for FIVE years and "parts" only thereafter from original date of purchase.

INCLUSIONS: "FIVE YEAR LIMITED WARRANTY"

- ❖ Five year limited warranty on the Burner System. Warranty will cover any defective burner if defect is deemed as original by the manufacturer.

The above will be covered "parts & labor" to the original purchaser for TWO years and "parts" only thereafter from original date of purchase.

INCLUSIONS: "ONE YEAR LIMITED WARRANTY"

- ❖ All 24 K gold trims and accessories against tarnishing.
- ❖ All trim accessories against tarnishing and paint defects.
- ❖ Blowers, fans and fan motors, wiring, rheostats and thermodises.
- ❖ Rocker switches, spill switches and wiring to them.
- ❖ Gas control valves, pilot assemblies including thermopiles, thermocouples, electrodes, and igniters.

The above will be covered "parts & labor" to the original purchaser for ONE year from date of purchase.

EXCLUSIONS:

- ❖ Ember material.
- ❖ Tempered Glass is under warranty for ONE year to the original purchaser from date of purchase.
- ❖ Travel time or mileage to original purchasers residence. Archgard suggests that you pre-arrange travel expenses with your Authorized Archgard Dealer.

WHAT TO DO IN THE EVENT OF A PROBLEM:

- ❖ Thoroughly read your manual.
- ❖ If you cannot solve the problem, contact your Archgard Dealer or representative.
- ❖ When calling for help please have the following information:

Model of your Fireplace	Serial Number	Place of Purchase
Date of Purchase	Problem Description	

- ❖ NOTE: Warranty may be void if work is carried out by an unqualified person (s). Only original Archgard parts may be used. Please consult your Archgard dealer or representative if in doubt about a replacement part (s).

OBTAINING WARRANTY SERVICE:

To obtain warranty service, the original purchaser shall return the defective part (s) to the original authorized Archgard selling dealer transportation prepaid, along with the serial number of the appliance and proof of purchase. Any defective part, in our judgment, will be repaired or replaced at Archgard's discretion. The dealer must obtain approval from Archgard before any repairs are made.

WARRANTY LIMITATION:

THIS LIMITED WARRANTY IS MADE IN LIEU OF ALL OTHER WARRANTIES, EXPRESSED OR IMPLIED AS TO QUALITY, MERCHANTABILITY OR FITNESS FOR PARTICULAR PURPOSE.

The appliance is only warranted for the use as intended by the installation and operating instruction and local building codes. The warranty will not cover damage due to accident, misuse, abuse, alteration, improper installation or "Acts Of God".

This limited warranty is void unless the appliance is installed by a qualified installer, in accordance with the instructions furnished with the appliance. Some Provinces or States do not allow limitations on how long an implied warranty lasts, so the above limitation may not apply to the original purchaser. Any damage resulting from defects in this product, is limited to the replacement of the defective part (s) and does not include incidental and consequential exposures sustained in connection with the product. This includes facing (s), mantle (s), cabinet (s), tile (s) or any other finishes resulting from removal of any gas appliance. This warranty is limited to residential use only and gives the consumer specific rights. These rights may vary from State to State or Province to Province.

FREQUENTLY ASKED QUESTIONS

Listed below are some frequently asked questions regarding Archgard Gas Fireplaces. If you have questions that are not listed below, or are not answered in this manual, please contact your Authorized Archgard Dealer.

Q. My glass has a condensation “fog” when the appliance is first lit.

A. Condensation is normal and will disappear in a few minutes after the glass is heated.

Q. I have a white “film” on my glass. What is the best way to clean the inside of the glass.

A. Frequent cleaning of your glass is recommended. Archgard recommends using a good quality “gas fireplace” glass cleaner that is available at all authorized dealers. Do not use abrasive materials, and do not clean the glass or the appliance when the unit is hot.

Q. How do I care for my plated trims.

A. Archgard recommends a cleaning with a damp cloth. DO NOT use chemical cleaners as they may harm the finish, and void your warranty. NOTE: If the top louvers, or top overlay starts to discolor, check the door gasket seal and replace if necessary.

Q. My fan/blower makes a “whirring” or “humming” noise.

A. Your Archgard gas appliance uses a powerful fan to push heated air into your room. It is not unusual to hear a “humming” noise when your fan is running. Note: the sound will change depending on the setting that your fan speed control is set at.

Q. I hear a “ticking”, “cracking” or “pinging” sound when my fireplace is running, and after it is turned off.

A. The different gauges of steel used to manufacture your fireplace will expand and contract at different rates when your fireplace is on, and will continued as your fireplace completes its heating function. You will likely hear these same sounds more on start up and shut down. This is normal for steel fireplaces.

Q. I hear a “click” when my main burner turns ON or OFF.

A. Your Gas Control Valve will make a clicking sound when it opens to allow gas to flow to the main burner. This is a normal part of the operating system.

Q. Can I burn wood and other materials in my gas fireplace.

A. No! Burning anything other than natural or LP gas in a gas fireplace or stove will create a potential fire hazard and present a danger to your home and its occupants. Only burn the gas fuel for which the unit was originally designed.

Q. Can I shut my pilot off in the summer?

A. You will save energy by turning off the pilot light if you are not using your appliance for the hot summer months. Remember to relight it before you want to use the appliance for the first time in the fall. Refer to your owners manual for lighting instructions.

Q. Can I position my gas logs in a different fashion or use a different log set?

A. No. Your gas fireplace is an engineered system that includes the firebox, burner, logs, venting and options which are tested and listed by CSA. Changing any specifications or placement of the logs could void your manufacturer's warranty, and possible even your homeowner's warranty.

REPLACEMENT PARTS LIST - ARCHGARD 27-DVIE22N

Item #	Item Description	Unit
200-1127	Owner's Manual	EA
308-6011	SIT Pro Flame II Electronic Control Module	EA
308-6014	SIT Pro Flame II Handheld Transmitter	EA
308-6017	SIT 885 Gas Valve c/w Step Motor	EA
305-6002	Module Main Wiring Harness (5 wire)	EA
305-6003	Valve Wiring Harness (4 wire)	EA
305-0060	Battery Holder (4-AA)	EA
301-0068	Orifice (Main Burner Orifice) Drill to # 43 DMS for Natural Gas	EA
	Orifice (Main Burner Orifice) Drill to # 54 DMS for LP Gas	EA
308-0119	Pilot Assembly, conv. PSE IPI	EA
827-1050	Burner Assembly	EA
733-0027	Pilot Shield	EA
27-CKELP	Conversion Kit NG to LP	EA
27-CKENG	Conversion Kit LP to NG	EA
305-0019	On/Off Rocker Switch	EA
RF-305-0024	Replacement Cross-flow Fan (120VAC, 115V, 24 watt)	EA
827-0000	Complete Replacement Door Black. Includes glass, gasket and door frame	EA



WARRANTY REGISTRATION

**ARCHGARD INDUSTRIES LTD.
7116 BEATTY DRIVE
MISSION, B.C. CANADA
V2V 6B4**

FOLD DOWN AT LINE

fire-parts.com

FOLD DOWN AT LINE & TAPE CLOSED

Model # : 27-DVIE22 Serial #: _____ Date Installed: _____ / _____ / _____
mm dd yyyy

Name: _____ Address: _____

City: _____ State/Prov: _____ ZIP: _____ Phone: (_____) _____

Dealer's Name & Address: _____

City: _____ State/Prov: _____ ZIP: _____ Phone: (_____) _____

Installer's Name & Address: _____

City: _____ State/Prov: _____ ZIP: _____ Phone: (_____) _____

Why did you choose this product? _____

Thank you for purchasing our product and filling out this warranty card.

CUT ALONG LINE

CUT ALONG LINE

CUT ALONG LINE

fire-parts.com

ARCHGARD INDUSTRIES LTD.

7116 BEATTY DRIVE
MISSION, B.C. V2V 6B4
CANADA

WEBSITE: WWW.ARCHGARD.COM