



# OPTIMA 35 - 1

## GAS FIREPLACE INSERT ROOM HEATER

FOR USE WITH NATURAL GAS OR  
PROPANE



## USERS

## INSTALLATION

## OPERATION &

## MAINTENANCE MANUAL

**WARNING:** If the information in this manual is not followed exactly, fire or explosion may result causing property damage, personal injury or loss of life.

— Do not store or use gasoline or other flammable vapors and liquids in the vicinity of this or any other appliance.

— **WHAT TO DO IF YOU SMELL GAS**

- Do not try to light any appliance.
- Do not touch any electrical switch; do not use any phone in your building.
- Immediately call your gas supplier from a neighbor's phone. Follow the gas supplier's instructions.
- If you cannot reach your gas supplier, call the fire department.

— Installation and service must be performed by a qualified installer, service agency or the gas supplier.

**Installer: Please leave this manual with the appliance owner for future reference**



7116 Beatty Dr  
Mission, BC V2V 6B4  
Canada



200-0047

11APR01

# CONTENTS

<b>Introduction</b>	<b>3</b>
<b>General Information</b>	<b>4</b>
<b>Appliance Description</b>	<b>5</b>
<b>Dimensions and Clearances</b>	<b>6</b>
<b>Installation Instructions</b>	<b>8 - 14</b>
<b>Operation Instructions</b>	<b>15 - 17</b>
<b>Maintenance</b>	<b>18</b>
<b>Trouble Shooting Instructions</b>	<b>19 - 20</b>
<b>Wiring Diagrams</b>	<b>21</b>
<b>Servicing</b>	<b>22 - 24</b>
<b>Replacement Parts</b>	<b>25</b>
<b>Warranty</b>	<b>26</b>

## CAUTION

Due to high temperatures, the appliance should be located out of traffic and away from furniture and draperies.

Children and adults should be alerted to the hazards of high surface temperature and stay away to avoid burns or clothing ignition.

Young children should be carefully supervised when they are in the same room as the appliance.

Clothing or other flammable material should not be placed on or near the appliance.

Do not operate with cracked or broken glass. Be careful not to strike or slam the glass.

Installation and repair must be done by a qualified service person. Any parts removed or opened for servicing of the appliance must be properly replaced prior to operating the appliance.

The appliance must be inspected before use and at least annually by a qualified service person. More frequent cleaning maybe required due to excessive lint from carpeting, bedding material, etc. It is imperative that the control compartments, burners and circulating air passageways for the appliance be kept clean.

Patents Pending

## INTRODUCTION

Congratulations for choosing an Archgard fireplace.

The Optima 35 is one of the most advanced fireplace insert heaters available. It is solidly designed using the latest technology and manufactured to the highest quality. It is our aim to provide you an appliance with many trouble free years of reliable service.

Some of the many features are:

- **Heater Classification** The Optima 35 is classified as a heating appliance. Therefore, it has additional safety devices built-in and it can be operated continuously for zone heating.
- **High Efficiency** The Optima 35 has one of the highest efficiencies of any gas fireplace; which means that it is less expensive to operate.
- **Adjustable Fan Speed** Each unit comes complete with a heat activated circulation fan with a fully adjustable speed control.
- **Adjustable Flame** The flame aesthetics and heat output can be adjusted to suit the owner's liking and heating needs.
- **Solid Construction** The Optima 35 is constructed mainly of 16 and 18 gauge galvanized steel for long life and durability.
- **Optional Decorative Accessories** Check with your dealer for a full compliment of decorative accessories to suit your home décor and your tastes, including; gold tone louvers, a variety of surround faceplates with optional trims and even an overlay bay door which is simply attached to the front of the unit while leaving the flat door in place.

**Please read the manual carefully prior to installation and operation of the appliance. Proper installation, operation and maintenance of the appliance will provide you with many years of enjoyment.**

## GENERAL INFORMATION

### APPLIANCE CERTIFICATION

This appliance is tested and certified to the following US and Canadian gas appliance standards.

- ANSI Z21.88a-1998/CSA 2.33a-M98, Vented Gas Fireplace Heaters,
- ANSI Z21.44-1995, CAN1-2.19-M81, Direct Vent Wall Furnaces
- CAN/CGA-2.17-M91, Gas-Fired Appliances for Use at High Altitudes

Please contact Archgard Industries Ltd., if you have any questions regarding the certification of this appliance.

### INSTALLATION CODES

This appliance must be installed by a qualified gas appliance installer.

The installation must conform with the local codes or, in the absence of local codes, with the current National Fuel Gas Code, ANSI Z223.1/ NFPA 54, in the US or Installation Code, CAN/CGA-B149, in Canada. Electrical connections and grounding must conform with local code, or current National Electrical code, ANSI/NFPA No. 70-1987, in the US and in Canada, the current Canadian Electrical Code, CSA C22.1.

### SPECIFICATIONS

	Natural Gas (NG)	Propane (LP)
<b>Manifold Pressure</b>	0.9 - 3.5 in. w.c. (0.2 - 0.9 kPa)	3.6 - 10.0 in. w.c. (0.9 - 2.5 kPa)
<b>Min. Supply Pressure for Purpose of Input Adjustment</b>	4.5 in. w.c. (1.2 kPa)	11.0 in. w.c. (2.8 kPa)
<b>Orifice Size</b>	#34 DMS (2.82 mm dia)	#50 DMS (1.70 mm dia)
<b>Nominal Input Rating</b>	17,500 - 35,000 BTU/hr (5.1 - 10.2kW)	17,000 - 34,000 BTU/hr (5.0 - 10kW)
<b>Output (Fan On) @ Max. Rating</b>	28,800 BTU/hr (8.4 kW)	27,100 BTU/hr (7.9 kW)
<b>Output (Fan Off) @ Max. Rating</b>	27,700 BTU/hr (8.1 kW)	25,400 BTU/hr (7.4 kW)
<b>Altitude</b>	0 - 4,500 ft. (0 - 1372 m)	0 - 4,500 ft. (0 - 1372 m)
<b>Primary Air Opening</b>	1/8 in. (4.8 mm)	1/4 in. (9.6 mm)

### HIGH ALTITUDE INSTALLATION

When installing this appliance beyond 4500 ft. (1372 m) above sea level. The appliance must be properly de-rated and installed according to local codes, in the absence of local codes, with the current National Fuel Gas Code, ANSI Z223.1/ NFPA 54, in the US or Installation Code, CAN/CGA-B149, in Canada.

**APPLIANCE DESCRIPTION**

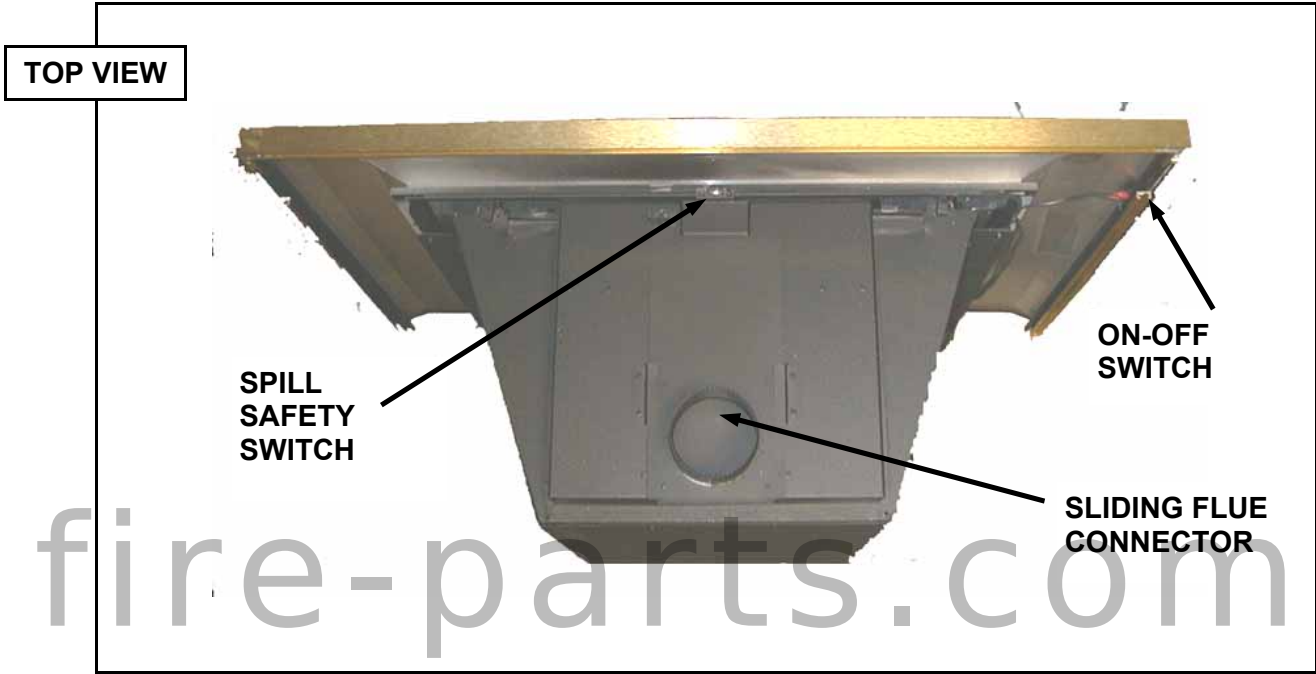

**DIMENSIONS AND CLEARANCES**

**APPLIANCE DIMENSIONS**

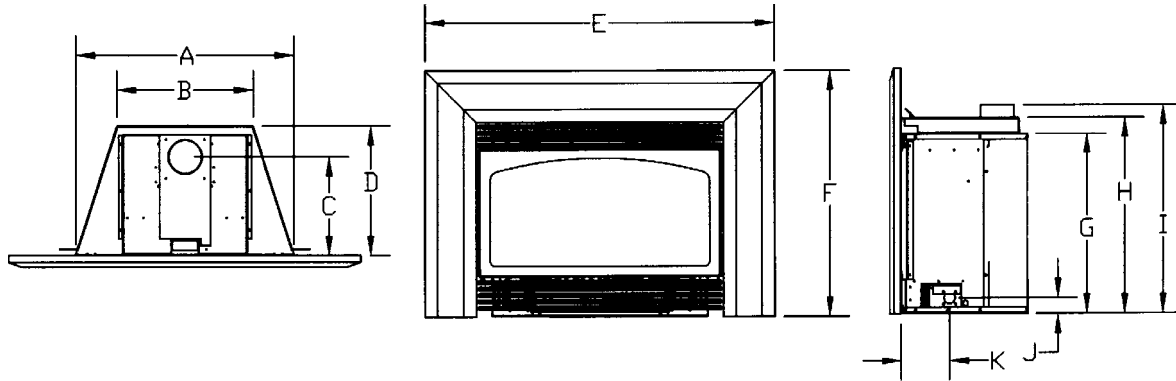

- A 25 5/8" (651 mm)
- B 16" (406 mm)
- C 11 3/8" (289 mm)
- D 15" (381 mm)

With standard aluminum surround

- E 41 1/2" (1054 mm)
- F 28 3/4" (730 mm)

- G 20 7/8" (530 mm)
- H 22 5/8" (575 mm)
- I 24 1/8" (613 mm)
- J 1 3/4" (45 mm)
- K 5 3/4" (146 mm)

With oversize steel surround

- E 47 1/2" (1207 mm)
- F 31 3/4" (807 mm)

Flue Collar - 4" (102 mm) diameter

**MINIMUM FIREPLACE DIMENSIONS**

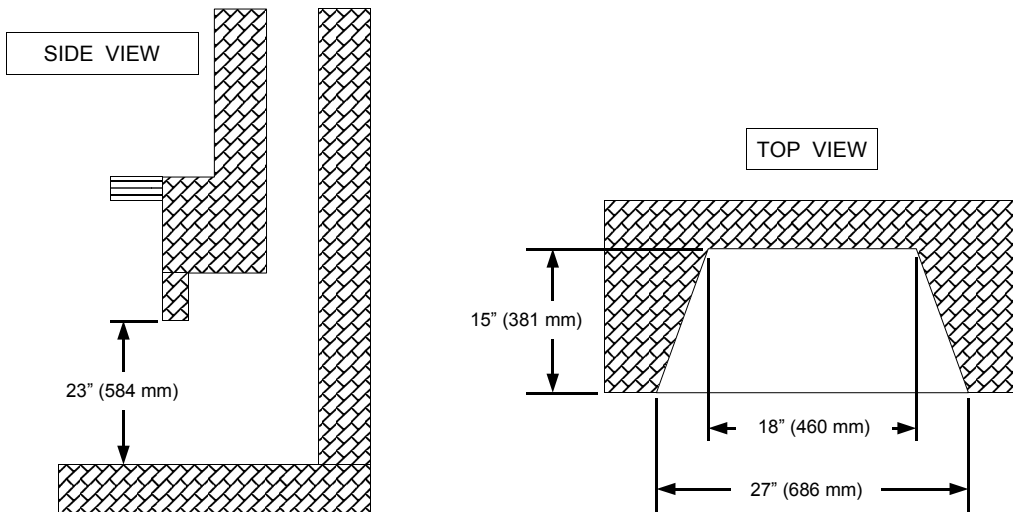

**DIMENSIONS AND CLEARANCES Cont...**

**CLEARANCES TO COMBUSTIBLES**

**SIDE VIEW**

Combustible mantle allow in shaded area. Mantle extension maybe increased 1" (25mm) for each additional 1" (25mm) increase in clearance height.

**Note:** With bay window attached clearances remain the same.

**Note:** If existing wood fireplace hearth protection is removed it must be replaced by a non combustible hearth protection extending 16" from the front of the fireplace insert.

**TOP VIEW**

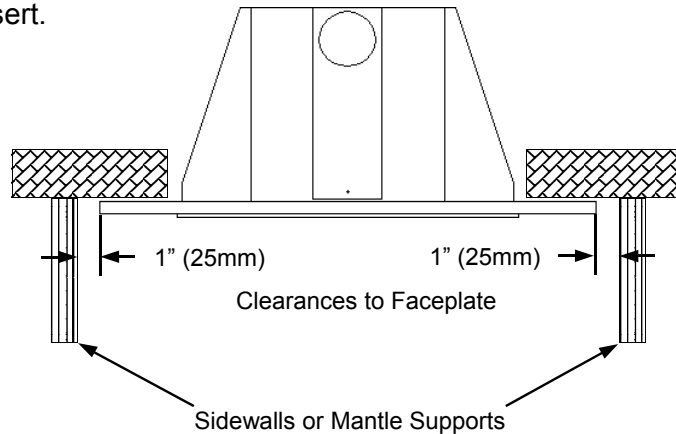

**WARNING:** Failure to position the parts in accordance with these diagrams or failure to use only parts specifically approved with this appliance may result in property damage or personal injury

**CAUTION:** This appliance is designed for used in any masonry or factory built wood burning fireplace. It cannot be enclosed by combustible material and used as a built-in gas fireplace.

## INSTALLATION INSTRUCTIONS

### PRECAUTIONS

This appliance must be installed by a qualified gas installer and the installation conform to the installation codes.

This appliance needs fresh air for safe operation and must be installed so there are provisions for adequate combustion and ventilation air. Provide adequate clearance around air openings of the appliance. Never obstruct front openings.

Provide adequate clearances for proper operation and servicing of the appliance.

This appliance must be properly connected to a venting system and must not be connected to a chimney flue serving a separate solid fuel burning appliance.

### GAS CONNECTIONS

Have your gas supplier or a qualified gas fitter run a gas supply line into the fireplace. The line must be properly sized and fitted according to the installation codes. Immediately up stream of the supply connection, the fitter shall provide an accessible manual shut-off valve and a 1/8 NPT plugged tapping accessible for connection to a test gauge.

**CAUTION:** The appliance and its individual shutoff valve must be disconnected from the gas supply piping system during any pressure testing of that system at test pressures in excess of 1/2 psig (3.5 kPa). The appliance must be isolated from the gas supply piping system by closing its individual manual shutoff valve during any pressure testing of the gas supply piping system at test pressures equal to or less than 1/2 psig (3.5 kPa). Failure to do so will damage the appliance's gas valve. Such damage is not covered by the manufacturer's warranty.

#### **Natural Gas Pressure Settings:**

The inlet supply or line pressure must be a minimum of 4.5" wc (1.1 kPa) and a maximum of 8" wc (2 kPa). The orifice has a #34 hole.

ELEVATION	INPUT RATING
0-4500 ft. (0-1400 m)	35,000 BTU/hr (10,200 watts)
4500 ft. (1400 m) +	35,000 BTU/hr (10,200 watts) less 4% per 1000 ft. (300m)
<i>Please contact your Archgard dealer or distributor for the appropriate orifice size above 4500'.</i>	

#### **Propane Pressure Settings:**

The inlet supply or line pressure must be a minimum of 11" wc (2.8 kPa) and a maximum of 14" wc (3.5 kPa). The orifice has a #50 hole.

ELEVATION	INPUT RATING
0-4500 ft. (0-1400 m)	34,000 BTU/hr (10,000 watts)
4500 ft. (1400 m) +	34,000 BTU/hr (10,000 watts) less 4% per 1000 ft. (300m)
<i>Please contact your Archgard dealer or distributor for the appropriate orifice size above 4500'.</i>	

**NOTE:** THE INPUT RATING SHOULD ALWAYS BE CHECKED WHEN FIRST RUNNING THIS APPLIANCE. To do this, reduce the background flow rate, time the meter, light the fireplace and take another reading after 15 minutes of operation. Check with your gas supplier for the gas BTU content at your elevation. Input is the rate of flow multiplied by the heating value of the gas (cubic feet/hour x BTU per cubic feet). Adjust the manifold pressure so that the unit does not operate above the rated input. To do this, loosen the screw on the variable input knob on the valve and reposition that the maximum input is correct. Retighten the screw.



**INSTALLATION INSTRUCTIONS Cont...**

Before connecting the appliance to the gas supply line, double check that the appliance you have purchased is design for the gas type you are using. The gas type markings are located on the certification label and also on the appliance's gas valve.

Adequate clearance for proper installation and checking of the gas connections must be provided. All gas connections must be checked for gas leaks.

**ELECTRICAL CONNECTIONS**

The Optima 35 comes complete with an electrical cord and plug already installed. If you require to run an electrical lead to the appliance instead, follow the instructions listed below.

Have qualified electrician run a set of 120VAC supply lines to the lower left side of the fireplace before installing the appliance. He should leave 18" (460mm) of the supply line free for ease of connection to the appliance. Connect the electrical supply line to the appliance at the same time the gas line is being connected to the appliance.

Flip open the bottom grill and undo the 2 screws holding the control panel. Run the lines into the left side of the appliance through the conductor clamp. Run the lines through the conductor clamp on the controller box. Connect the 'live' (black) supply conductor to the free black conductor from the speed controller with a marrette type wire connector. Connect the 'neutral' white supply conductor to the free white conductor from the convection fan with a marrette type wire connector. Connect the 'ground' (green or bare) conductor to the ground screw formerly used by the cord and plug. Replace the control panel and fasten with the 2 screws.

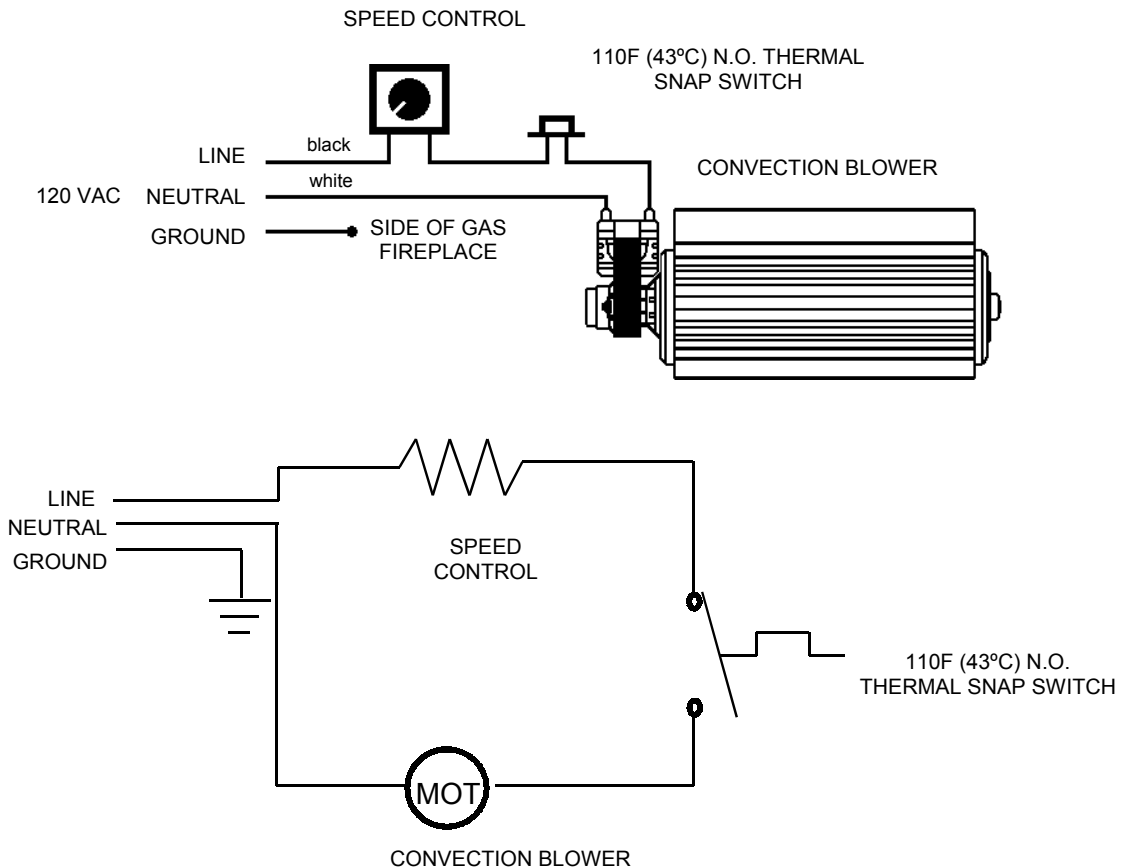

## INSTALLATION INSTRUCTIONS Cont...

### VENTING

The appliance is equipped with a vent safety shutoff system and a safety control system designed to protect against improper venting of combustion products. The appliance will not function without being connected to a proper venting system.

**WARNING: Operation of this heater when not connected to a properly installed and maintain venting system or tampering with the vent shut-off system can result in carbon monoxide (CO) poisoning and possible death. This appliance must not be connected to a chimney flue serving a separate solid fuel burning appliance. The draft hood opening behind the top louvers must not be obstructed in any way.**

The appliance may be vented using 4 in. diameter aluminum or stainless steel flexible gas flue liner running inside a masonry chimney or the flue of the factory built fireplace. The vent system must be properly terminated with a suitable vent cap. This cap must be sealed to the liner with a silicone type high temperature sealer. The liner must form a complete connection from the flue collar to the vent cap. If maximum heating efficiency is desired, it is recommended to seal between liner and chimney using non backed fiberglass insulation above the appliance. Follow the vent component manufacturer's instruction. Also check with local gas authorities for proper venting methods and procedures.

The appliance has a detachable flue connection plate for ease of installation. (see page 11). A 45° adapter is available if the vertical orientation of the outlet is difficult to use (Part# FAE-25).

**WARNING:** Maximum distance between front of unit and front of flue pipe is 15 1/2"

**CAUTION:** To ensure that the venting path is not accidentally obstructed, damper of the host fireplace must be permanently disabled. This means either complete removal of the damper or welding it in it's "open" position. Temporarily disabling the damper with braces, wedges, brackets, etc., is not allowed.

After the flexible gas liner has been properly installed in the fireplace, attach the collar of the connector plate to the liner with screws or a clamp. Before placing the appliance into the fireplace, check the hearth of the fireplace to see if it is level with the front of the fireplace. If it is not, measure the depth of the hearth. Loosen the three screws of the leveling "L" bracket at the back of the appliance. Lower it to the measurement obtained and tighten the screws.

Make sure the gas and electrical lines are properly connected to the appliance. Slide the unit into the fireplace and slide the flue plate back onto the top of the appliance. Fasten the pull bar with the screw provided in the hood edge so that the flue adapter cannot slide back out (see page 11). Attach the faceplate to the appliance before sliding it all the way into the fireplace. The return flange on the side of the face plate fits on the inside of the mounting rails on the appliance and has been designed for easy straight on fit up. Attach the faceplate to the appliance at the locations shown with the four (4) black screws provided.



**INSTALLATION INSTRUCTIONS Cont...**

**SWITCH WIRING**



SPILL SAFETY SWITCH

ON-OFF SWITCH WIRING

SPILL SWITCH WIRING

WIRE CLIP

GROMMET

fire-parts.com

**SLIDING FLUE ADAPTER**

WARNING:  
Maximum clearance between front of unit and front of flue pipe is 15 1/2"

9" to 15 1/2"

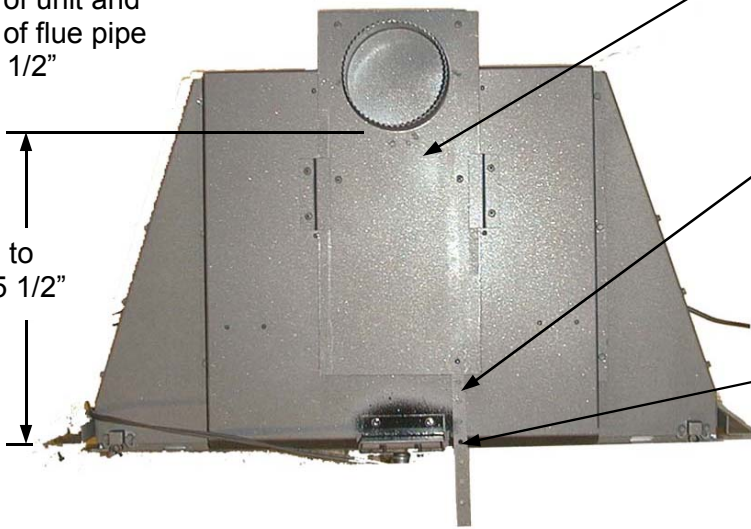

SLIDING FLUE ADAPTER

FLUE PULL AND FASTENING BAR

SCREW HERE AFTER INSTALLATION AND CUT OFF EXCESS BAR

**INSTALLATION INSTRUCTIONS Cont...****SWITCH MOUNTING AND WIRING****SPILL SWITCH:**

The spill switch is located in a critical location to shut off the appliance in the event the draft is insufficient. It is located above and in front of the draft hood. Do not tamper with its location. In the event of insufficient draft the heat from the venting gases shuts off the gas to the burner.

**ON-OFF SWITCH:**

The on-off switch is located in the side trim. The wire must be run along the frame as shown and clipped together with the spill switch wire. Run the wire through the same grommet as the spill switch wire (see page 11). Attach to valve terminals as shown on page 14.

**GLASS DOOR**

**WARNING: THE OPTIONAL BAY DOORS ARE DECORATIVE ACCESSORIES ONLY. LEAVE THE FLAT DOOR IN PLACE!**

Do not attempt to remove the glass door when the appliance is hot.

**Removing the Glass Door**

Release the two latches underneath the door.

Lift out the bottom of the door and lift the whole door assembly up and off the two locating tabs at the top of the door assembly.

**Replacing the Glass Door**

The reverse procedure of Removing the Glass Door.

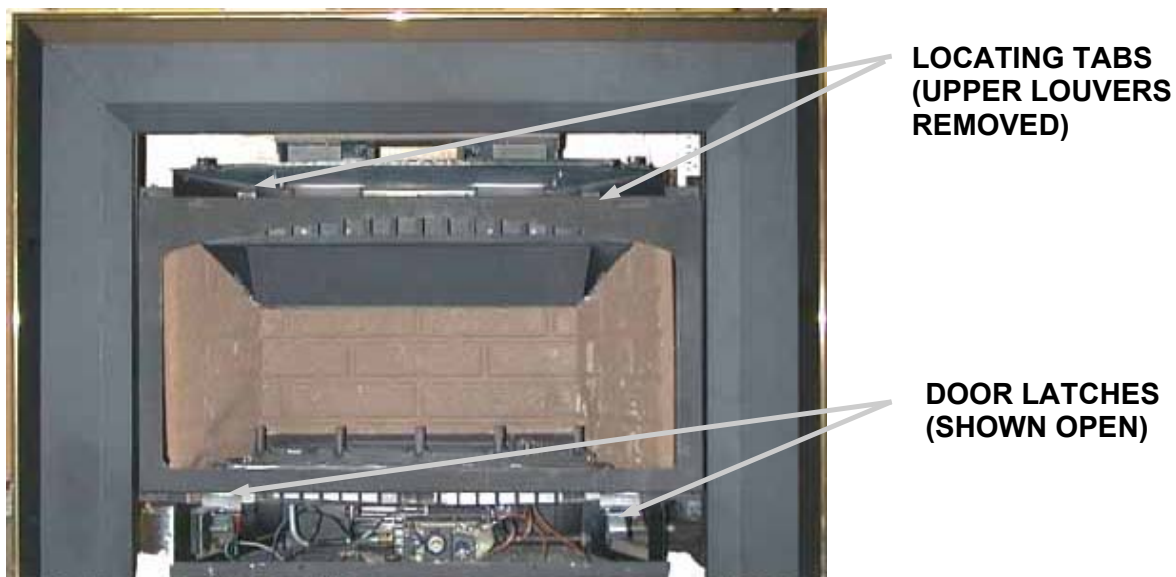

## INSTALLATION INSTRUCTIONS Cont...

### PLACEMENT OF LOGS AND BRANCH

Locate the rear log on the locator pins and then the front logs on it's pins. The branch fits over top as shown. It is locked into place with a pin on the Left Front Log and sits on the edge of the knot hole in the rear log. Both the Left and Right Front Logs must be positioned on their locating pins behind the front burner.



### PLACEMENT OF EMBERS

A small bag of embers and coals are provided with the fireplace. Carefully place the embers and coals on the ledge between the grate and the front of the burner. Try not to allow the embers to obstruct the burner ports.



**WARNING:** Do not place logs in any other configuration than that shown. Under no circumstances are logs to be modified. Do not add materials to the burner other than the type and amount that has been supplied by Archgard with the unit.

## INSTALLATION INSTRUCTIONS Cont...

### OPTIONAL BAY DOOR INSTALLATION

**WARNING:** THE OPTIONAL BAY DOOR IS A DECORATIVE OPTION ONLY AND IS MANUFACTURED WITH TEMPERED GLASS. THIS UNIT MUST NOT BE OPERATED WITHOUT THE FLAT CERAMIC DOOR SECURED IN PLACE, BEHIND IT.

**NOTE:** Ensure that the fireplace is turned off and cool, disconnect the power to the unit.

- 1 Remove the upper grilles by pulling the assembly forward.
- 2 Remove the lower grilles by removing the four hex head mounting screws.
- 3 Remove the two hex head screws from the existing Control Panel Bracket, and pull the assembly out from under the firebox.
- 4 Remove the Fan Control Knob, remove the mounting nut, push the rheostat back out of the hole, and disconnect the quick connect plugs from the wire and the thermal switch on the underside of the firebox.
- 5 Plug the included 10" black extension wires onto the rheostat wires, the power wire, and the spade connector of the thermal switch on the underside of the firebox, see Fig. 1.
- 6 Remove the sparker wire from the existing piezo sparker.
- 7 Place the rheostat through the corresponding hole in the Bay Control Panel Bracket so that the wires extend to the left, tighten the nut, and push the knob back on.
- 8 Install the 6" Hi/Low and 6" On/Off extension knobs onto the corresponding knobs on the valve.
- 9 Place the Bay Control Panel Bracket over the extension knobs, move the rear bend over the bottom bend of the heater, and insert the left side in front of the Fan Control Bracket.
- 10 Line up the corresponding mounting holes, see Fig. 2, and turn the two new hex head screws in.
- 11 Push the sparker wire onto the new piezo on the Knob Extension Kit Bracket.
- 12 Move the Bay Assembly over the front of the insert, line up the slots in the upper area slightly above the corresponding tabs at the front top of the firebox, and push the assembly down.

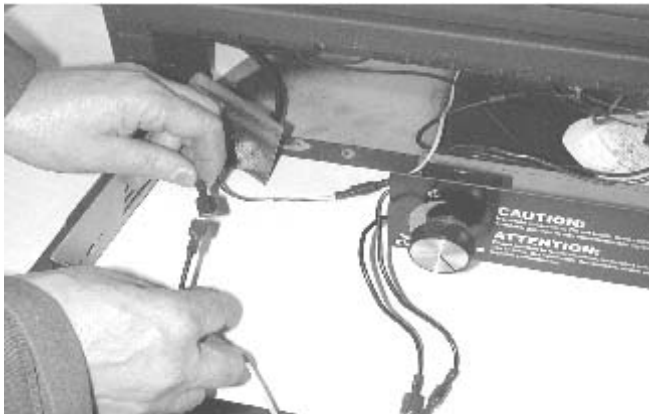

**Fig. 1**

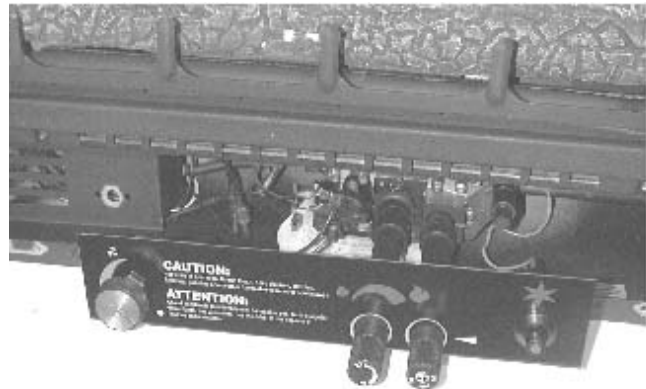

**Fig. 2**

**OPERATION INSTRUCTIONS****FOR YOUR SAFETY, READ BEFORE LIGHTING****INITIAL OPERATION**

- Check that the appliance is properly vented and connected to the gas supply.
- Check that the logs and branches are properly placed.
- Check that all external parts, such as grills, door and faceplate are properly attached and fastened.
- Check that there are no finger prints left on gold surfaces as high temperature can bake these prints permanently.

**NOTE :** When operated for the first few times, the appliance will emit some odor and fumes. This is due to the heat from the appliance evaporating the oils and solvents used in fabricating the appliance. Close off the room to the rest of the house and open all windows. Keep the room well ventilated as smoke alarm may sound. Run the appliance for at least 4 hours at maximum setting with blower set to "OFF" to allow paint to cure.

**WARNING :** If you do not follow these instructions exactly, a fire or explosion may result, causing property damage, personal injury or loss of life. Do not operate the appliance with the glass front removed, cracked or broken. Replacement of the glass should be done by a licensed or qualified service person.

- A.** This appliance has a pilot which must be ignited using the sparker located next to the appliance valve controls. When lighting the pilot, follow the start-up procedures exactly.
- B.** BEFORE LIGHTING, smell all around the appliance area for gas. Be sure to smell next to the floor, because some gases are heavier than air and will settle on the floor.
- IF YOU SMELL GAS, follow the instruction on the front cover of this manual.
- C.** Use only your hand to push in or turn the gas control knob. Never use tools. If the knob will not push in or turn by hand, don't try to repair it. Call a qualified service technician. Force or attempted repair may result in a fire or explosion.
- D.** Do not use this appliance if any part has been under water. Immediately call a qualified service technician to inspect the appliance and to replace any part of the control system and any gas control which has been under water.
- E.** This appliance is equipped with a three-prong (grounding) plug for your protection against shock hazard and should be plugged in directly into a properly grounded three-prong receptacle. Do not cut or remove the grounding prong from this plug.



## OPERATION INSTRUCTIONS Cont..

### AUTOMATIC VALVE START-UP PROCEDURE

1. Set the thermostat, if present, to the lowest level. Press slightly and turn the control knob clockwise  to the **OFF** position and wait 5 minutes; thus allowing any gases to escape which may have accumulated in the combustion chamber.

**Note:** LP gases do not vent upward. Then follow step 2 and 3 to establish pilot.

2. Press slightly and turn control knob counterclockwise  to **PILOT** position; depress control knob and light pilot by repeatedly pressing the sparker. Venting of air may take place prior to flow of pilot gases. Once flame is established, hold knob depressed for approximately 60 seconds.

3. Release knob. If pilot should go out, turn the control knob to **OFF** position and repeat steps 1, 2 and 3.

**Note:** The control valve is equipped with an internal safety interlock. You must leave at "off" position for about 5 minutes before lighting pilot again.

4. Press and turn control knob counterclockwise  to **ON** position.
5. Turn flame and heat adjustment knob to the desired comfort level from **HIGH** to **LOW**.
6. Turn thermostat to the desired comfort level or turn ON/OFF switch to the ON position.

### SHUT-DOWN PROCEDURE TO PILOT FLAME

7. To turn off the main burner only, set the thermostat to the lowest setting or turn switch to OFF. Press and turn the knob clockwise  to **PILOT** position.

### COMPLETE SHUT-DOWN PROCEDURE

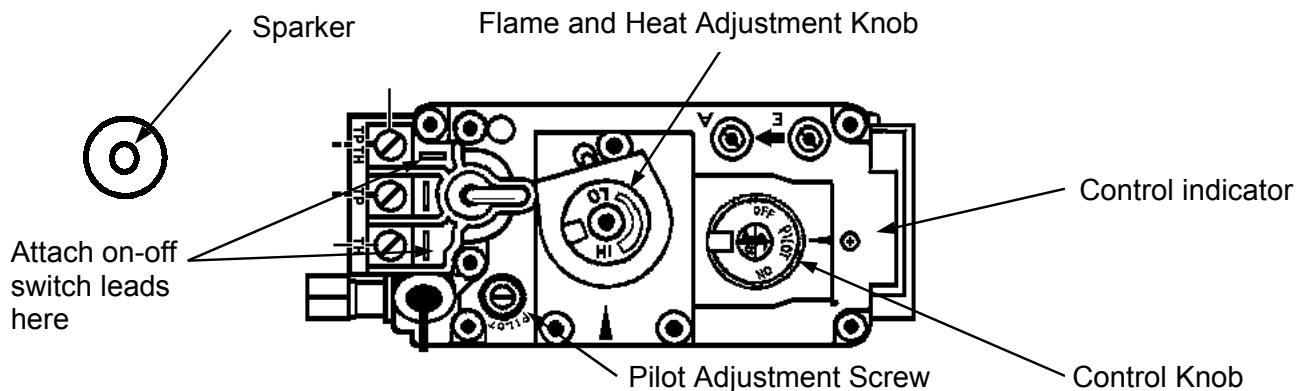

8. Press and turn the knob clockwise  to the **OFF** position.





## OPERATION INSTRUCTIONS Cont..

### MANUAL VALVE START-UP PROCEDURE

1. Press slightly and turn the control knob clockwise  to the **OFF** position and wait 5 minutes; thus allowing any gases to escape which may have accumulated in the combustion chamber.  
**Note:** LP gases do not vent upward. Then follow step 2 and 3 to establish pilot.
2. Press slightly and turn control knob counterclockwise  to **PILOT** position; depress control knob and light pilot by repeatedly pressing the sparker. Venting of air may take place prior to flow of pilot gases. Once flame is established, hold knob depressed for approximately 60 seconds.
3. Release knob. If pilot should go out, turn the control knob to **OFF** position and repeat steps 1, 2 and 3.  
**Note:** The control valve is equipped with an internal safety interlock. You must leave at "off" position for about 5 minutes before lighting pilot again.
4. Press and turn control knob counterclockwise  to **HIGH** position.
5. Turn control knob to the desired comfort level between the **HIGH** and the **LOW** range. This control incorporates a temperature sensor near the unit. Once set to a certain setting the flame will automatically modulate from "high" then to "low" and if need to "off" and back again to keep a constant room temperature. You will need to experiment to find the "right" setting.

### SHUT-DOWN PROCEDURE TO PILOT FLAME

6. To turn off the main burner only. Press and turn the knob clockwise  to **PILOT** position.

### COMPLETE SHUT-DOWN PROCEDURE

7. Press and turn the knob clockwise  to the **OFF** position.

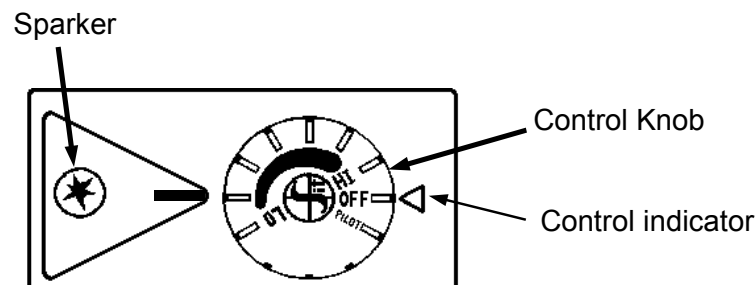

## MAINTENANCE

**CAUTION** : Do not conduct maintenance on the appliance while it is operating or while it is still hot.

### CLEANING THE APPLIANCE

The exterior painted surfaces, glass and gold trims may be cleaned with a soft, non-abrasive cloth and water or a suitable, mild, non-abrasive cleaner.

#### Regularly:

- Clean and remove any lint accumulations or debris from the grills and in any combustion and convection air passage ways.
- Keep the appliance area free from combustible materials, such as paper, wood, clothing, gasoline and flammable solids, liquids and vapors.
- Visually check the height and color of the burner and pilot flames.

#### Every 2 to 3 months:

- Remove the glass door and clean the inside of the glass with a soft, non-abrasive cloth and water or a suitable, mild, non-abrasive cleaner. **DO NOT CLEAN WHILE HOT.**
- Carefully remove the logs and gently brush off any loose carbon deposits. This job is best done outside the house, wearing a dust mask. The logs are very fragile, take care not to break them. **Do not wash logs with any liquid.** While logs are removed, also remove the coals or “embers” and check that all burner openings are not obstructed and it is recommended you use a vacuum cleaner to clean off any dust or lint.
- After cleaning, the logs and embers must be replaced as per the instructions in this manual.

#### Once a Year have a qualified service technician:

- Completely inspect the appliance and the venting system.
- Clean and remove any lint accumulations or debris in the firebox, on the burners, on the pilot, at the primary air opening, on the convection air blower and in any combustion and convection air passage ways.
- Check the safety system of the gas valve and the appliance.

**WARNING** : All parts removed or disturbed including guards and grills must be properly replaced after maintenance. Service and repair must be conducted by a qualified service person. If these instructions are not followed, a fire or explosion may result, causing property damage, personal injury or loss of life

## TROUBLE SHOOTING

Please check to make sure the instructions are followed exactly before attempting trouble shooting of the appliance.

**WARNING:** Trouble shooting and servicing of gas and electrical devices of the appliance should only be conducted by a qualified service technician.

SYMPTOM	ACTION
Pilot will not light after pressing the sparker many times.	<ol style="list-style-type: none"> <li>1. When lighting the appliance for the first time after installation or after servicing, there is air in the gas line. It takes a while for all the air to purge out of the pilot before gas can reach the pilot and ignite. Remove the glass door and try lighting the pilot many times to purge the air.</li> <li>2. Check to make sure the gas supply to the appliance is turned on and there is adequate gas supply pressure to the appliance.</li> <li>3. Check for sparks between the spark electrode and the pilot head when the sparker is pressed. If there are no sparks,               <ol style="list-style-type: none"> <li>a. Check for broken or poor connection from the sparker to the electrode.</li> <li>b. Check for the spark shorting or arcing at other locations.</li> <li>c. Check for defective sparker.</li> <li>d. Check for defective spark electrode.</li> </ol> </li> <li>4. With the door removed, try lighting the pilot with a match.               <ol style="list-style-type: none"> <li>a. If air is blowing on the flame of the match, hold the control knob in at the '<b>PILOT</b>' setting until all the air is purged out of the line.</li> <li>b. If there is no gas or air coming out of the pilot and there is gas pressure to the appliance, the pilot orifice may be blocked or the gas valve may be defective.</li> </ol> </li> </ol>
Pilot will not remain on after being lit.	<ol style="list-style-type: none"> <li>1. Press the control knob all the way in.</li> <li>2. Hold the control knob in for a longer period of time.</li> <li>3. If you are trying to re-light the pilot immediately after you have shut-off the pilot, you have to wait 5 minutes for the valve to reset.</li> <li>4. Check to see if the pilot flame is large enough to reach and surround the thermocouple. If the flame is too small, check for correct gas supply pressure. If pressure is good, adjust the pilot flame size with the adjustment screw on the valve. If the flame cannot be adjusted, there might be some debris obstructing the pilot orifice, or a wrong size pilot orifice.</li> <li>5. Check for poor connection of the thermocouple to the valve.</li> <li>6. Check for proper millivolts of the thermocouple. The thermocouple should generate at least 30 mV or it is defective.</li> <li>7. Check for defective gas valve.</li> </ol>
The main burner does not turn on with the pilot lit.	<ol style="list-style-type: none"> <li>1. Check to make sure the control knob is turned to the '<b>ON</b>' position.</li> <li>2. Allow enough time for the pilot to heat up the thermopile to generate sufficient voltage to activate the valve.</li> </ol>

## TROUBLE SHOOTING Cont...

SYMPTOM	ACTION
The main burner does not turn on with the pilot lit. Cont...	<ol style="list-style-type: none"> <li>3. Check to make sure the thermostat is set high enough to turn on the appliance.</li> <li>4. Check that the remote switch or the thermostat is turned on.</li> <li>5. Check for weak pilot flame. If flame is weak, check gas supply, check pilot flame adjustment and check for blockage of pilot orifice.</li> <li>6. Check all connections to the valve for tight electrical contact.</li> <li>7. Check spill switch for continuity.</li> <li>8. Check for 400-500 mV from the thermopile with the burner off and 200-250 mV with the burner on. If the voltages are lower, the thermopile is defective.</li> <li>9. Check for defective gas valve.</li> </ol>
The main burner shuts off when the appliance is warm.	<ol style="list-style-type: none"> <li>1. This may be the normal operation of a wall thermostat installed to appliances.</li> <li>2. Check for good pilot flames on the thermopile (see page 22).</li> <li>3. Check for good voltage from the thermopile.</li> <li>4. Check for proper functioning of venting system.</li> <li>5. Check wire connections. Expansion from heat affects a loose connection</li> </ol>
Sooty deposits on the glass door.	<ol style="list-style-type: none"> <li>1. If the flame is yellow and lazy, check for lint etc. around primary air shutter. Increase primary air by opening the primary air shutter if necessary.</li> <li>2. Check for proper placement of the logs and branches. Ensure logs and burner are clean. See that section in the instruction manual.</li> <li>3. Check for obstruction of the burner ports by the embers. See that section in the instruction manual.</li> <li>4. Check for proper venting and blockage of the vent termination.</li> <li>5. Check manifold pressure and clock input rating for over-firing.</li> </ol>
Sharp blue flames with flames lifting off the burner at the ends.	<ol style="list-style-type: none"> <li>1. Too much primary air. Reduce primary air by closing the primary air shutter. During cold temperatures, some flame lifting may occur during start-up.</li> </ol>
Convection blower does not turn on.	<ol style="list-style-type: none"> <li>1. The convection fan is thermostatically controlled. It will only turn on when the appliance is warmed-up. This may take up to 15 minutes with the appliance on high.</li> <li>2. Check for 120 VAC electrical supply to the appliance. (Is the cord plugged in?)</li> <li>3. Check for proper mounting of the thermal snap disc.</li> <li>4. Check electrical connections.</li> <li>5. Check for defective thermal snap disc.</li> <li>6. Check for defective convection blower speed controller.</li> <li>7. Check for defective convection blower.</li> </ol>

# WIRING DIAGRAMS

## CONVECTION BLOWER

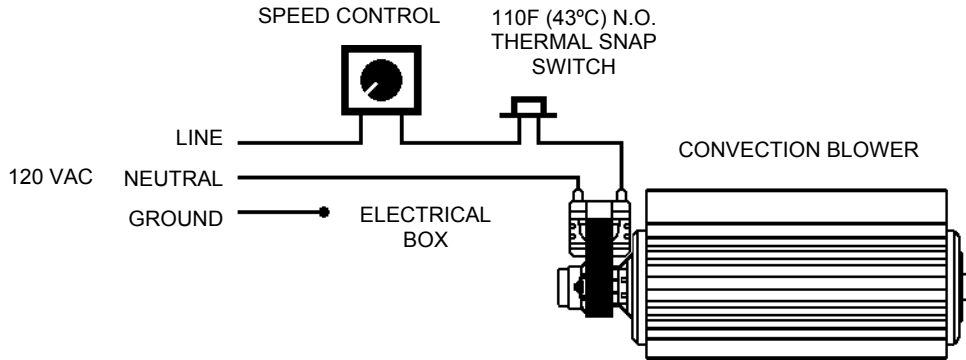

## AUTOMATIC VALVE

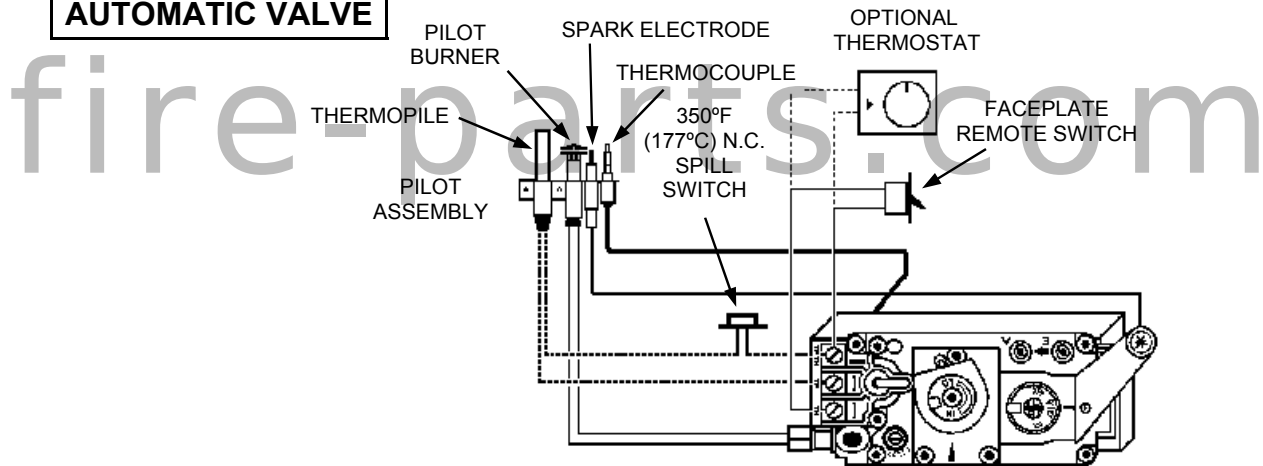

## MANUAL VALVE

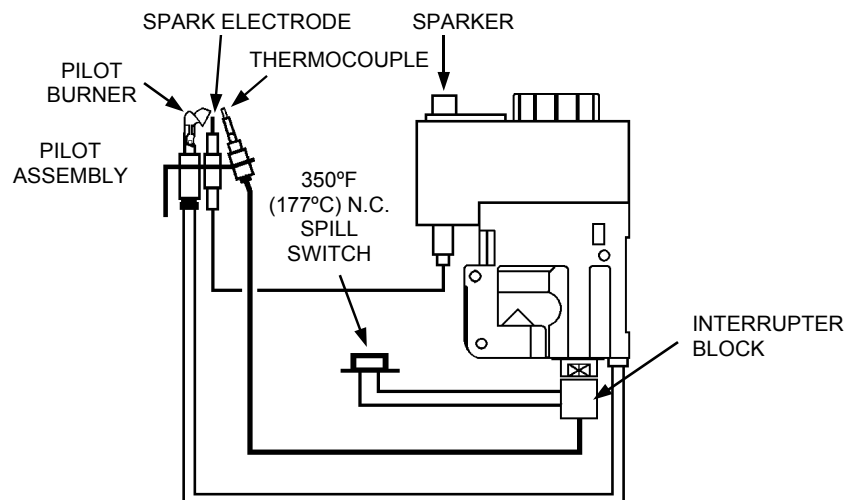

## SERVICING

### SERVICING UNDER WARRANTY

Before servicing, read the terms and conditions of the Archgard warranty at the back of the manual. Contact the Archgard authorized dealer which you have purchased the appliance from and provide him with details of the problem and the installation information which the installer has fill out at the back of the manual.

**WARNING:** Servicing of this appliance **must be conducted by a qualified service technician**. Improper servicing, adjustment or alteration of this appliance may cause property damage, personal injury or loss of life. All servicing should be conducted with the appliance cold. All replacement parts must be authorized by Archgard for suitability.

### ADJUSTING PRIMARY AIR

Note: the Shutter is set at the factory and normally only requires setting at higher altitudes.

- Open the lower grills.
- Unscrew the 2 screws holding the control panel and remove the panel.
- The primary air adjustment wing nut is located behind and to the left of the control valve.
- Loosen the wing nut and slide the primary air shutter to the right to increase primary air and to left to reduce primary air.
- Tighten the wing nut after adjustment.

**Caution:** Wear gloves when adjusting the primary air with the appliance hot.

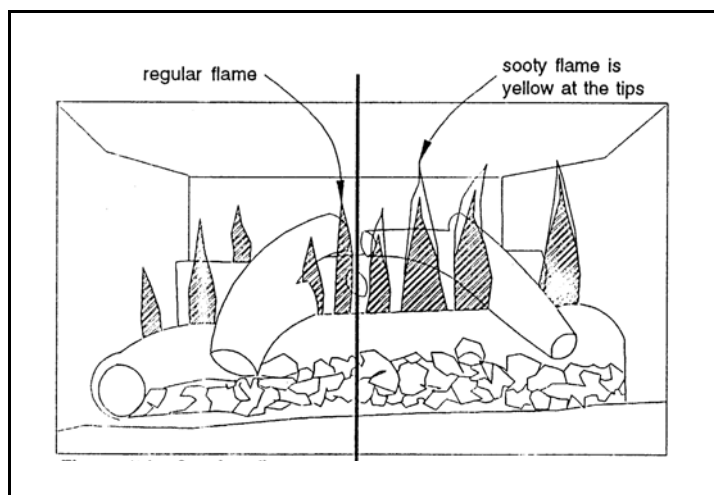
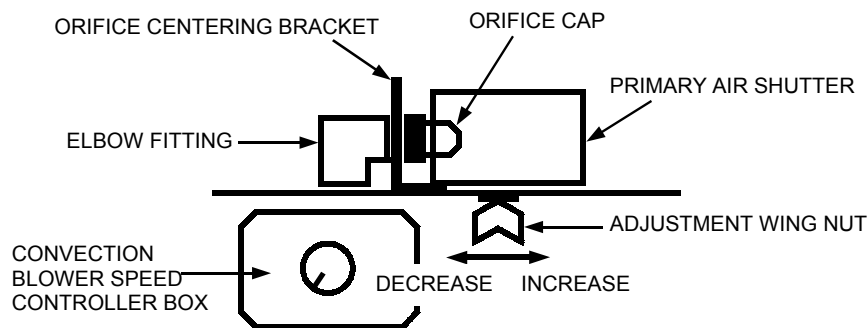

### FLAMES...

The left side shows correct adjustment. The right side shows yellow sooty flames requiring increase in shutter opening or cleaning of shutter area due to lint buildup.

## SERVICING Cont...

### CHANGING MAIN BURNER ORIFICE

- Remove the glass door, log branches and the front log.
- Unscrew the 2 screws holding the left burner shields between the burner tubes and remove the shield.
- Remove the adjustment wing nut and slide the air shutter away from the orifice cap.
- Use a 1/2" wrench to remove the orifice cap.
- Change the orifice cap. Use a small quantity of gas thread seal compound. Do not over tighten.
- Replace the adjustment wing nut and properly set the primary air shutter according to the specifications.
- Replace the burner shield, front log, branches and the glass door.

### CHECKING INLET AND OUTLET GAS PRESSURE

- Open the lower grills.
- The pressure test taps are located on the valve.

**Automatic valve:** The taps are located in the front. The inlet is marked 'IN' and the outlet is marked 'OUT'. There is also an arrow marking the direction of gas flow.

**Manual valve:** The taps are located on the left side of the valve. The connection closest to the back, marked with 'IN' is the inlet and the outlet marked with 'OUT' is closest to the front.

- Loosen the set screw inside the tap with a 1/8" wide flat screw driver.
- Connect a 1/4" rubber tube to the tap and a manometer.
- Be sure to tighten the set screw inside the tap after you are finish taking pressure readings.
- Check for leaks.

### CHECKING AND ADJUSTING PILOT

The pilot flame should have the characteristic as shown in the illustration below. The flame should not have yellow tips but should engulf the thermocouple and thermopile. It can be adjusted by turning the screw marked "pilot" on the control valve.

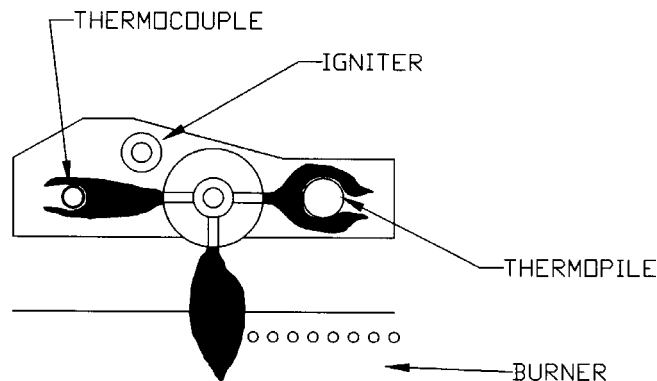

## SERVICING Cont...

### REPLACING PILOT ORIFICE

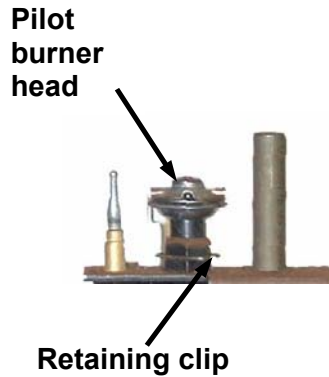

The pilot orifice sits underneath the pilot burner head. Remove the head just by pulling it off. You may have to wiggle it a bit. **DO NOT REMOVE THE RETAINING CLIP.** Use a 5/32 Allen wrench to remove the orifice. Replace in reverse order. There is a notch in the head to line it up correctly on replacement. Ensure the head is pushed down all the way.

fire-parts.com

### WHEN YOUR GLASS BREAKS

In the event your glass cracks or breaks, it must be replaced by the exact same size and material. It is made from high temperature ceramic material. See replacement parts list and contact your nearest Archgard dealer.

- Remove door and carefully remove all traces of glass and gasket material.
- Replacement requires Ceramic glass part #307-0022, gasket part #314-0000 and sealer part #319-0005.
- Install new glass with new gasketing in place. The “thicker” side of the gasket fits against the fireplace opening.
- Hold glass in place by using the sealer between gasket and door. Use sparingly so that no excess will be visible. **DO NOT PUT ANY SEALER BETWEEN GLASS AND UNIT OPENING.**
- Replace the door carefully making sure all three clamps are closed.

### REPLACING CONVECTION BLOWER

- Remove the gas component assembly, see above.
- Mark all wires to be removed for proper reassembly. **CAUTION:** Wiring errors cause improper and dangerous operation.
- The convection blower is located at the bottom of the appliance at the back. Remove the three screws holding the blower.
- Lift the blower out and disconnect the wires from the blower.





## Replacement Parts for OPTIMA 35

Item #	Item Description	Qty	Unit
200-0047	OWNER'S MANUAL, OPTIMA 35	1	EA
300-0030	HINGE, SELF-CLOSING BRASS	2	EA
300-0034	CATCH, DOOR LATCH, 1-11/16" x 1-3/16"	2	EA
301-0021	ORIFICE--CAP #50	1	EA
301-0045	ORIFICE--CAP #34	1	EA
305-0013	SPEED CONTROL, C/W PALE NUT & KNOB, 120V	1	EA
305-0015	ELECTRIC FAN, CROSSFLOW 115 V FAN LH	1	EA
305-0019	SWITCH ROCKER CARLING RA911-VB-B-1VXAG1	1	EA
305-0021	THERMODISC 110 DEG FAN SWITCH	1	EA
305-0027	SWITCH - BLANK ON/OFF CARLING 9711	1	EA
305-0035	THERMODISC 350 DEG LIMIT (L350-60F)	1	EA
307-0022	GLASS--CERAMIC 14-1/4 x 28 (OI35)	1	EA
307-0026	GLASS, 6MMTEMP 15.062x22.312 POL. 2 SHRT	1	EA
307-0027	GLASS,6MM TEMP 6.783x15.062 POL. 1 LONG	2	EA
308-0000	SIT THERMOCOUPLE 450 MM NOVA 820 PILOT	1	EA
308-0004	PIEZO CABLE 16" SIT	1	ea
308-0005	PIEZO IGNITOR C/W NUT (JBS), 66270-003	1	ea
308-0006	SIT EUROSIT COVER BLACK AND PIEZO	1	ea
308-0009	INTERRUPTER BLOCK SIT	1	EA
308-0012	VALVE, SIT NOVA MV HI-LO (LP)	1	ea
308-0013	VALVE, SIT NOVA MV HI-LO (NG)	1	EA
308-0014	VALVE - EUROSIT LP MANUAL	1	ea
308-0015	VALVE - EUROSIT NG MANUAL	1	EA
308-0046	KNOB EXTENSION ON/OFF 1 1/2"	1	EA
308-0047	KNOB EXTENSION HI/LO 1 1/2"	1	EA
308-0052	KNOB EXTENSION--ON/OFF 6"	1	EA
308-0053	KNOB EXTEBSION--HI/LO 6"	1	EA
308-0054	PILOT ASSEMBLY, CONVERTIBLE PILOT LP SIT	1	EA
308-0055	PILOT ASSEMBLY, CONVERTIBLE PILOT NG SIT	1	EA
310-0009	COALS, MEDIUM GRADE 4OZ BAG	1	EA
310-0032	LOG, REAR OPTIMA 35/70	1	EA
310-0033	LOG, CROSS OPTIMA 35/70	1	EA
310-0046	MINERAL WOOL, "EMBERS"	1	OZ
310-0070	Log, Front Left, Optima 35/70	1	EA
310-0071	Log, Front Right, Optima 35/70	1	EA
311-0025	BRICK LINER OPT35 REAR (701-1003)	1	EA
311-0026	BRICK LINER OPT35 RH (701-1004)	1	EA
311-0027	BRICK LINER OPT35 LH (701-1004)	1	EA
312-0017	CONNECTOR, GAS 3/8 MIP x 3/8 FIP x 12"	1	EA
314-0000	GASKET GF - TADPOLE 1.38"	85	IN
314-0002	GASKET GF FLAT .500"	64	IN
703-0009	GRILLE LOUVERS	9	EA
703-0011	FIRE BOX BAFFLE	1	EA
800-0010	WIRING HARNESS, FIREPLACE INSERTS	1	EA
800-0020	ELECTRIC CORD ASSEMBLY	1	EA

Parts can be ordered through your local dealer or distributor by giving ITEM # and DESCRIPTION.



## ARCHGARD LIMITED WARRANTY

This Limited Warranty is made by ARCHGARD INDUSTRIES LTD. hereinafter referred to as "Archgard". Archgard warrants to the original consumer that the gas burning fireplaces will be free from defects in materials and workmanship under normal use and service, for a lifetime.

### INCLUSIONS:

- Combustion chamber, burner pans & burner tubes, log sets (including embers & brick panels) and all gold plating.
- Electrical components and gas valves are covered under the warranty for a period of 1 year from purchase.

### EXCLUSIONS:

- Paint, glass, trim, gasket, parts which have been tampered with or modified in any way.
- Negligence, misuse, accidental damage.
- Special environmental conditions, which may cause spillage or downdraft conditions due to negative room air pressure, geographical location, inadequate ventilation or excessive offsets.

### WHAT TO DO IN THE EVENT OF A PROBLEM:

- Thoroughly read your manual.
- If you cannot solve the problem yourself contact your Archgard dealer or representative.
- When calling for help have the following information available:

<b>Model Name</b>	<b>Serial Number</b>	
<b>Place of Purchase</b>	<b>Date of Purchase</b>	<b>Problem Description</b>

**NOTE:** Warranty may be void if work is carried out by unqualified personnel. Only original Archgard parts may be used. Please consult your Archgard representative if in doubt.

### OBTAINING WARRANTY SERVICE:

To obtain warranty service, the consumer shall return the defective part to the original selling dealer transportation prepaid, along with the serial number of the appliance and proof of purchase. Any defective part, in our judgment, will be repaired or replaced at Archgard's discretion. The dealer must obtain approval from an authorized Archgard representative before any repairs are made.

### WARRANTY LIMITATION:

THIS LIMITED WARRANTY IS MADE IN LIEU OF ALL OTHER WARRANTIES, EXPRESSED OR IMPLIED AS TO QUALITY, MERCHANTABILITY OR FITNESS FOR PARTICULAR PURPOSE.

The appliance is only warranted for the use as intended by the installation and operating instructions and local building codes. The warranty will not cover damage due to accident, misuse, abuse, alteration or improper installation.

This limited warranty is void unless the appliance is installed by a qualified installer, in accordance with the instructions furnished with the appliance. Some Provinces or States do not allow limitations on how long an implied warranty lasts, so the above limitation may not apply to the consumer.

Any damages resulting from defects in this product, is limited to replacement of defective parts and does not include incidental and consequential expenses sustained in connection with the product.

This warranty is limited to residential use only and gives the consumer specific rights. These rights may vary from State to State or Province to Province.

Postage

**WARRANTY REGISTRATION**

**ARCHGARD INDUSTRIES LTD.  
7116 BEATTY DRIVE  
MISSION, B.C. CANADA  
V2V 6B4**

FOLD DOWN AT LINE

fire-parts.com

FOLD DOWN AT LINE & TAPE CLOSED

Model No: \_\_\_\_\_ Date Installed: \_\_\_\_/\_\_\_\_/\_\_\_\_

Name & Address: \_\_\_\_\_

Telephone: ( \_\_\_\_\_ ) \_\_\_\_\_ - \_\_\_\_\_

Dealer's Name & Address: \_\_\_\_\_

Installer's Name & Address: \_\_\_\_\_

Why did you choose this product? \_\_\_\_\_

*Thank you for purchasing our product and filling out this warranty card.*