



OPTIMA 45-1

DIRECT VENT FREE STANDING GAS HEATER

FOR USE WITH NATURAL GAS OR
PROPANE

USERS

INSTALLATION

OPERATION & MAINTENANCE MANUAL

WARNING: If the information in this manual is not followed exactly, fire or explosion may result causing property damage, personal injury or loss of life.

— Do not store or use gasoline or other flammable vapors and liquids in the vicinity of this or any other appliance.

— **WHAT TO DO IF YOU SMELL GAS**

- Do not try to light any appliance.
- Do not touch any electrical switch; do not use any phone in your building.
- Immediately call your gas supplier from a neighbor's phone. Follow the gas supplier's instructions.
- If you cannot reach your gas supplier, call the fire department.

— Installation and service must be performed by a qualified installer, service agency or the gas supplier.

Installer: Please leave this manual with the appliance owner for future reference



7116 Beatty Dr
Mission, BC V2V 6B4
Canada



200-0048
18AUG00

CONTENTS

Introduction	3
General Information	4
Appliance Description	5
Dimensions and Clearances	6
Installation Instructions	7—16
Operation Instructions	17—18
Maintenance	19
Trouble Shooting Instructions	20—21
Wiring Diagrams	22
Servicing	23—24
Replacement Parts	25
Warranty	26

CAUTION

Due to high temperatures, the appliance should be located out of traffic and away from furniture and draperies.

Children and adults should be alerted to the hazards of high surface temperature and stay away to avoid burns or clothing ignition.

Young children should be carefully supervised when they are in the same room as the appliance.

Clothing or other flammable material should not be placed on or near the appliance.

Do not operate this appliance with the glass front removed, cracked or broken. Be careful not to strike or slam the glass. Replacement of the glass should be done by a licensed or qualified service person.

Installation and repair must be done by a qualified service person. Any parts removed or opened for servicing of the appliance must be properly replaced prior to operating the appliance.

The appliance must be inspected before use and at least annually by a qualified service person. More frequent cleaning maybe required due to excessive lint from carpeting, bedding material, etc. It is imperative that the control compartments, burners and circulating air passageways for the appliance be kept clean.

Patents Pending

INTRODUCTION

Congratulations for choosing an Archgard fireplace.

The Optima 45 is one of the most advanced direct vent fireplace heaters available. It is solidly designed using the latest technology and manufactured to the highest quality. It is our aim to provide you an appliance with many trouble free years of reliable service.

Some of the many features are:

- **Heater Classification** The Optima 45 is classified as a heating appliance. Therefore, it has additional safety devices built-in and it can be operated continuously for zone heating.
- **High Efficiency** The Optima 45 has one of the highest efficiencies of any gas heater; which means that it is less expensive to operate.
- **Adjustable Flame** The flame aesthetics and heat output can be adjusted to suit the owner's liking and heating needs.
- **Solid Construction** The Optima 45 is constructed mainly of 14 and 18 gauge galvanized and aluminized steel for long life and durability.
- **Optional Thermostatic Control** The gas control system is "thermostat" ready for any millivolt wall thermostat or wireless remote control

Please read the manual carefully prior to installation and operation of the appliance. Proper installation, operation and maintenance of the appliance will provide you with many years of enjoyment. We recommend you record the following information:

Heater Model Number _____
Heater Serial Number _____
Date of Installation _____
Dealer's Name _____

GENERAL INFORMATION

APPLIANCE CERTIFICATION

This appliance is tested and certified to the following US and Canadian gas appliance standards.

- ANSI Z21.88a-1998/CSA 2.33a-M98, Vented Gas Fireplace Heaters,
- ANSI Z21.44-1995, CAN1-2.19-M81, Direct Vent Wall Furnaces
- CAN/CGA-2.17-M91, Gas-Fired Appliances for Use at High Altitudes

Please contact Archgard Industries Ltd., if you have any questions regarding the certification of this appliance.

INSTALLATION CODES

This appliance must be installed by a qualified gas appliance installer.

The installation must conform with the local codes or, in the absence of local codes, with the current National Fuel Gas Code, ANSI Z223.1/ NFPA 54, in the US or Installation Code, CAN/CGA-B149, in Canada. Electrical connections and grounding must conform with local code, or current National Electrical code, ANSI/NFPA No. 70-1987, in the US and in Canada, the current Canadian Electrical Code, CSA C22.1.

SPECIFICATIONS

	Natural Gas (NG)	Propane (LP)
Manifold Pressure	0.9-3.5 in. W.C. (0.2-0.9 kpa)	3.6-10.0 in. W.C. (0.9-2.5kpa)
Min. Supply Pressure for Purpose of Input Adjustment	4.5 in. w.c. (1.2 kPa)	11.0 in. w.c. (2.8 kPa)
Orifice Size	#37 DMS (2.66mm dia.)	#52 DMS (1.6mm dia.)
Nominal Input Rating	14,000 - 28,000 BTU/hr (4.1 - 8.2 kW)	17,000 - 28,000 BTU/hr (5.0 - 8.2 kW)
Output (Fan Off) @ Max. Rating	21,000 BTU/hr (6.2 kW)	21,000 BTU/hr (6.2 kW)
Altitude	0-4500 ft (0 - 1370 m)	0 - 4500 ft (0 - 1370 m)
Primary Air Opening	0.19 in. (4.8 mm)	0.35 in. (8.9 mm)

HIGH ALTITUDE INSTALLATION

When installing this appliance beyond 4500 ft. (1372 m) above sea level. The appliance must be properly de-rated and installed according to local codes, in the absence of local codes, with the current National Fuel Gas Code, ANSI Z223.1/ NFPA 54, in the US or Installation Code, CAN/CGA-B149, in Canada.

APPLIANCE DESCRIPTION

FRONT VIEW



APPLIANCE DIMENSIONS

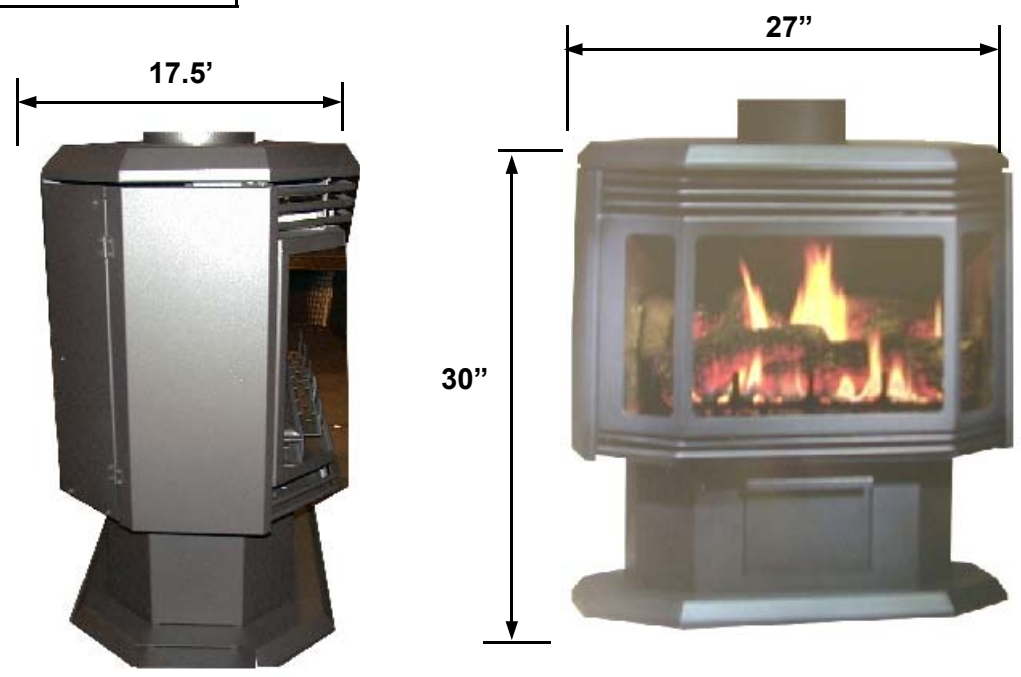

DIMENSIONS AND CLEARANCES

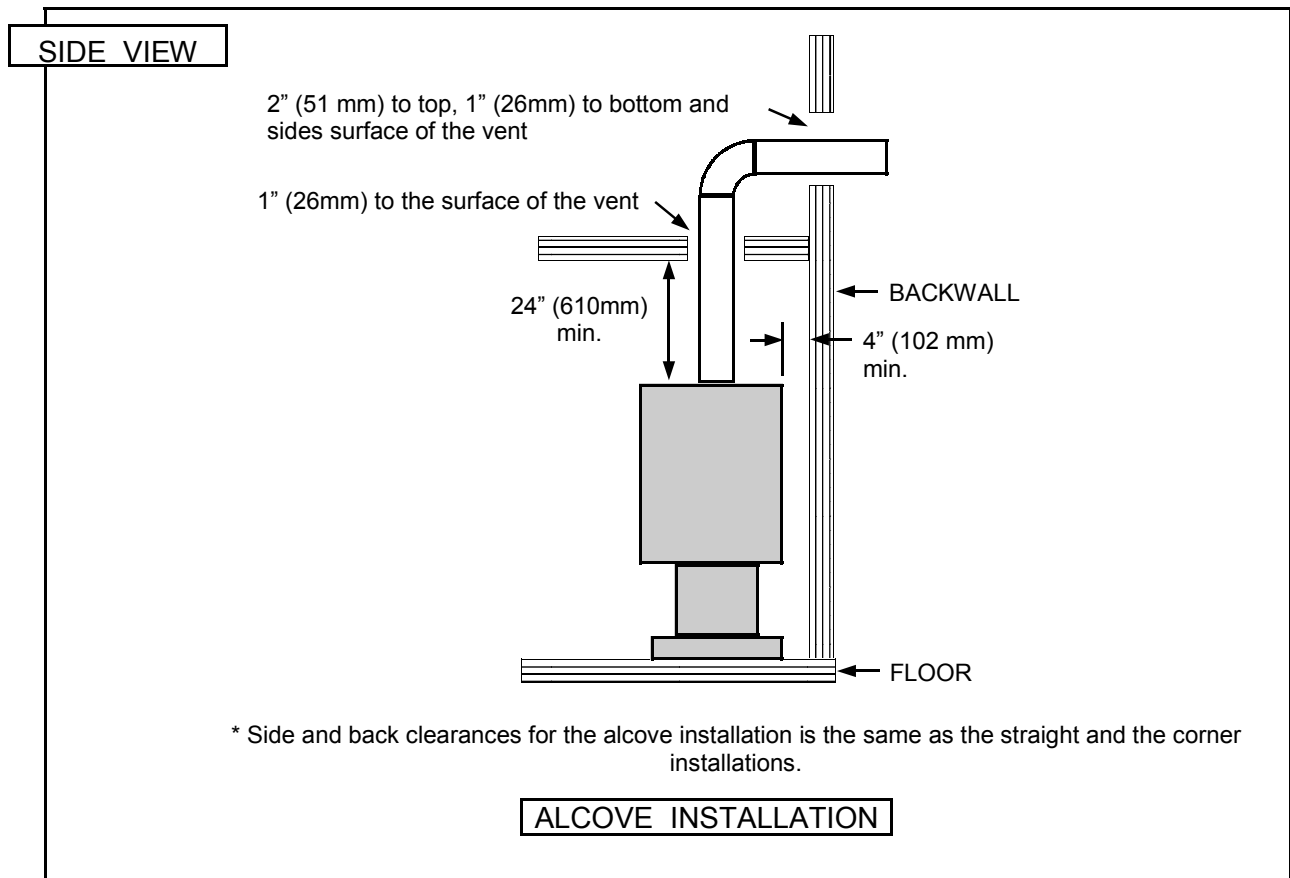
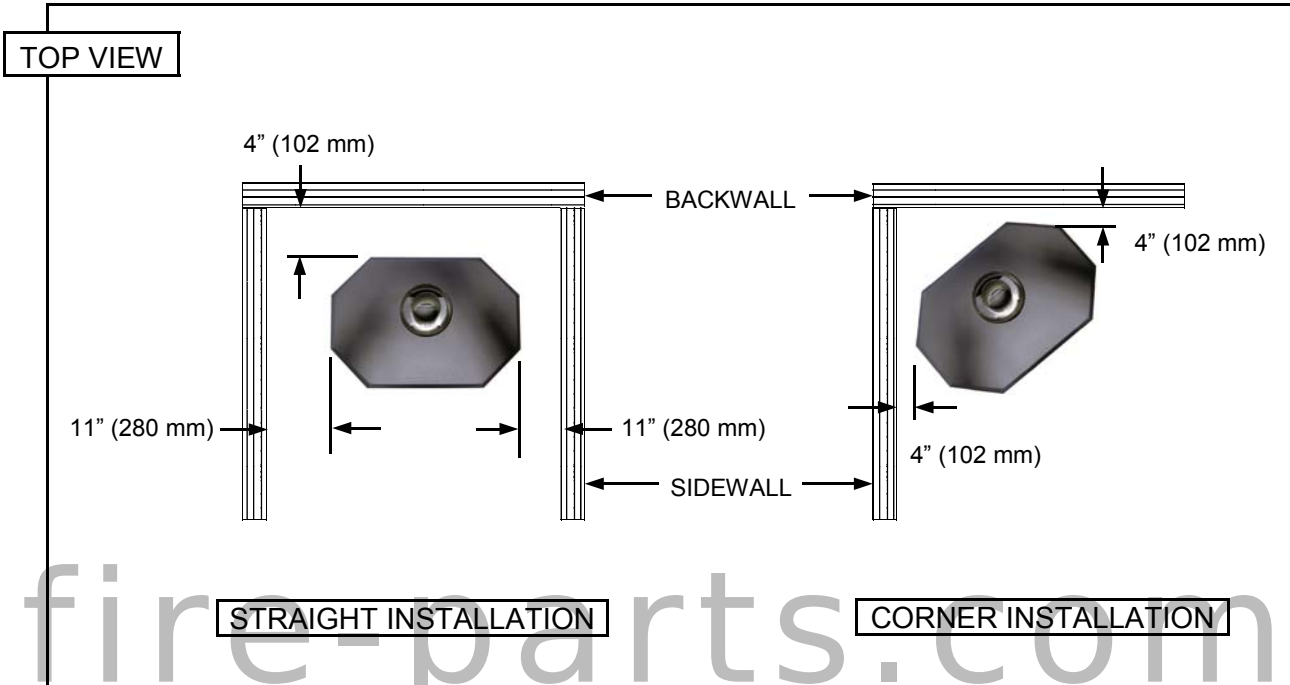

INSTALLATION INSTRUCTIONS

PRECAUTIONS

- This appliance must be installed by a qualified gas installer and the installation must conform to the installation codes.
- Provide adequate clearance around air openings of the appliance. Never obstruct front openings.
- Provide adequate clearances for proper operation and servicing of the appliance.
- This appliance must be properly connected to a venting system.
- This gas appliance must not be connected to a chimney serving a separate solid-fuel burning appliance.
- Do not use this appliance if any part has been under water. Immediately call a qualified service technician to inspect the appliance and to replace any part of the control system and any gas control which has been under water.
- This appliance is equipped with a three-prong (grounding) plug for your protection against shock hazard and should be plugged directly into a properly grounded three-prong receptacle. Do not cut or remove the grounding prong from this plug.
- **Caution:** Label all wires prior to disconnection when servicing controls. Wiring errors can cause improper and dangerous operation.
- Verify proper operation after servicing.
- Do not use substitute materials.
- Do not abuse glass doors by striking or slamming shut.
- Do not use abrasive cleaners.

LOCATING GAS HEATER

This appliance must be installed in any location that is free of plumbing, electrical wiring and heating or air conditioning ducts. Select a location that is accessible for venting. See ALLOWABLE TERMINATION LOCATIONS.

GAS CONNECTIONS

Have your gas supplier or a qualified gas fitter run a gas supply line into the heater. The line must be properly sized and fitted according to the installation codes. Immediately up stream of the supply connection, the fitter shall provide an accessible manual shut-off valve and a 1/8 NPT plugged tapping accessible for connection to a test gauge.

CAUTION: The appliance and its individual shutoff valve must be disconnected from the gas supply piping system during any pressure testing of that system at test pressures in excess of 1/2 psig (3.5 kPa). The appliance must be isolated from the gas supply piping system by closing its individual manual shutoff valve during any pressure testing of the gas supply piping system at test pressures equal to or less than 1/2 psig (3.5 kPa). Failure to do so will damage the appliance's gas valve. Such damage is not covered by the manufacturer's warranty.

INSTALLATION INSTRUCTIONS

Natural Gas Pressure Settings:

The inlet supply or line pressure must be a minimum of 4.5" wc (1.1 kPa) and a maximum of 8" wc (2 kPa). The orifice has a #37 hole.

ELEVATION	INPUT RATING
0-4500 ft. (0-1400 m)	28,000 BTU/hr (8,200 watts)
4500 ft. (1400 m) +	28,000 BTU/hr (8,200 watts) less 4% per 1000 ft. (300 m) or reduce manifold pressure by 0.25" wc (0.06 kPa) per 1000 ft. (300m)

Propane Pressure Settings:

The inlet supply or line pressure must be a minimum of 11" wc (2.8 kPa) and a maximum of 14" wc (3.5 kPa). The orifice has a #53 hole.

ELEVATION	INPUT RATING
0-4500 ft. (0-1400 m)	28,000 BTU/hr (8,200 watts)
4500 ft. (1400 m) +	28,000 BTU/hr (8,200 watts) less 4% per 1000 ft. (300m) or reduce manifold pressure by 1" wc (0.25 kPa) per 1000 ft. (300m)

NOTE: THE INPUT RATING SHOULD ALWAYS BE CHECKED WHEN FIRST RUNNING THIS APPLIANCE. To do this, reduce the background flow rate, time the meter, light the fireplace and take another reading. Check with your gas supplier for the gas BTU content at your elevation. Input is the rate of flow multiplied by the heating value of the gas (cubic feet/hour x BTU per cubic feet). Adjust the manifold pressure so that the unit does not operate above the rated input. To do this, loosen the screw on the variable input knob on the valve and reposition that the maximum input is correct. Retighten the screw.

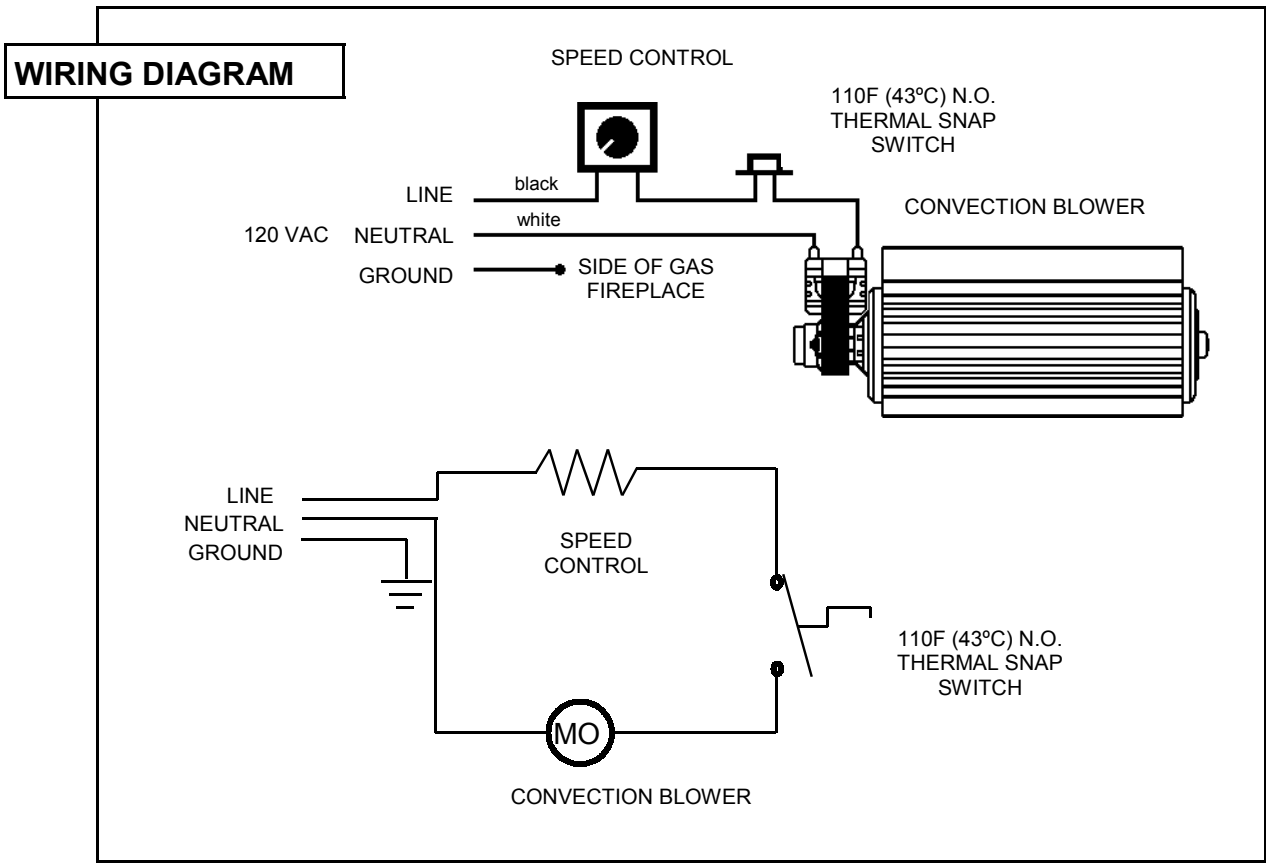

INSTALLATION INSTRUCTIONS Cont...

VENT TERMINATION

1. See ALLOWED TERMINATION LOCATIONS (page 11) and establish a suitable vent termination location.
2. In heavy snowfall areas make sure vent termination is located where it can not be block by snow or snow from snow removal equipment.
3. Locate vent termination away from plants, bushes or any other object near the vent termination that will interfere or obstruct the air flow around it.
4. DO NOT recess vent termination into walls, sidings or planters.
5. Vent terminations located below 7ft from grade level or anywhere that it can be a burn hazard to the public, such as patios and balconies, must be protected with an Archgard approved termination cage.

TERMINATION
FRAMING

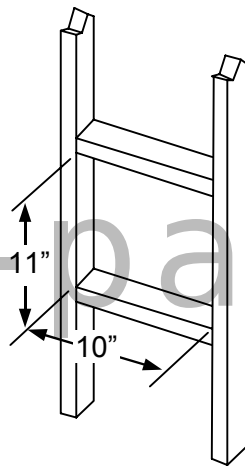

NOTE: Be sure to include 1/4" rise per foot of horizontal length.

For best venting performance, here are some general venting rules that we recommend:

1. Use only Archgard or Simpson Dura Vent direct vent systems and components.
2. Maintain a minimum of 1" (26 mm) clearance to combustibles from the outside surfaces of vertical vents and minimum of 1" (26 mm) sides and bottom, and 2" (51 mm) from top surfaces of horizontal vents.
3. Observe any local code restrictions, if any, regarding the installation of this type of gas appliance.
4. Observe the venting chart given in this manual.
5. Use vent spacers between the inside and outside vents at every 3 ft (915 mm) intervals (Archgard vent kits only).
6. Never slope horizontal vents downwards.
7. Maintain at least a rise of 1/4" (7 mm) for every 1 ft (305 mm) of horizontal vent.
8. Terminate the vent with a suitable vent termination supplied by Archgard Part # TK-1 or Simpson Dura Vent.

INSTALLATION INSTRUCTIONS Cont...

VENTING

The appliance will not function without being connected to a proper venting system. This appliance may only use direct vent system supplied by Archgard, or Simpson Dura-Vent direct vent systems with Archgard SDK-1 adapter.

VENTING CHART

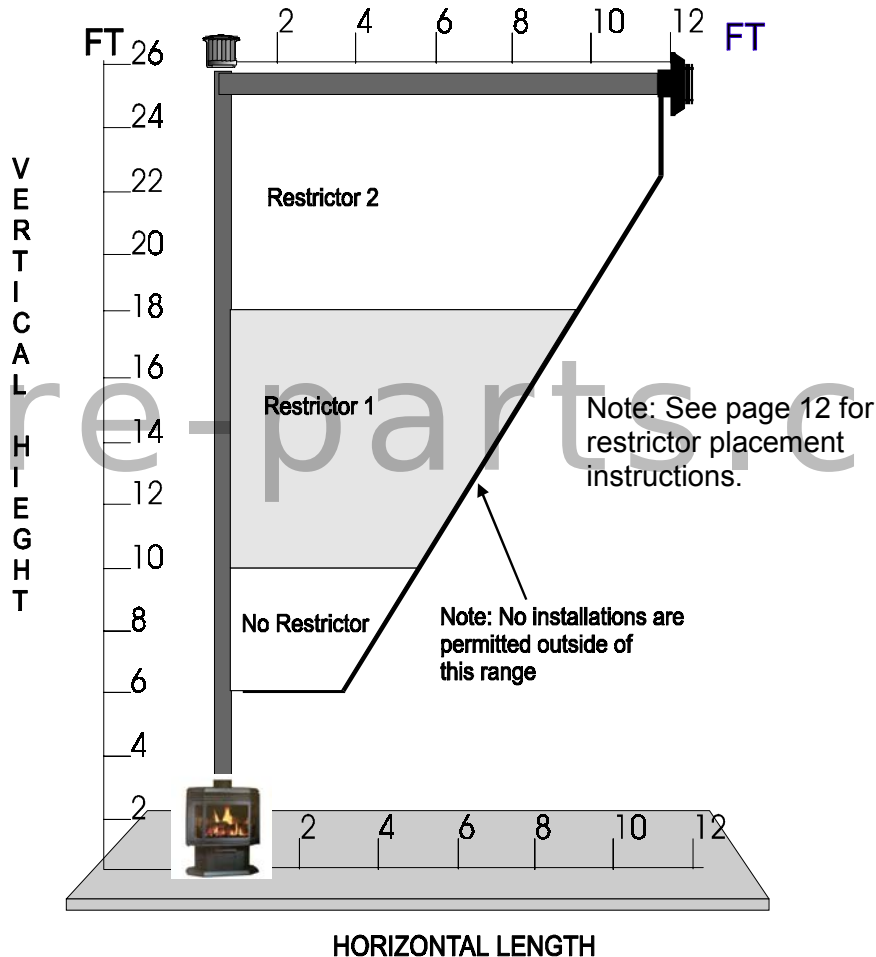

- Chart is for one 90° bend, with 1/4" (7 mm) vertical raise minimum per foot of horizontal length.
- For each additional 90° or two 45°, add one foot of vertical height.
- Maximum three 90° bends, or equivalent.
- Minimum 2 ft (610 mm) straight length between bends.

VENTING ABOVE ROOF OF THE HOUSE USING A VERTICAL TERMINATION

Use Simpson Dura-Vent listed direct vent system caps for all vertical vent termination applications (through the roof).

Please follow the venting instructions as strictly as possible to obtain the best performance from the appliance.

ALLOWED TERMINATION LOCATION

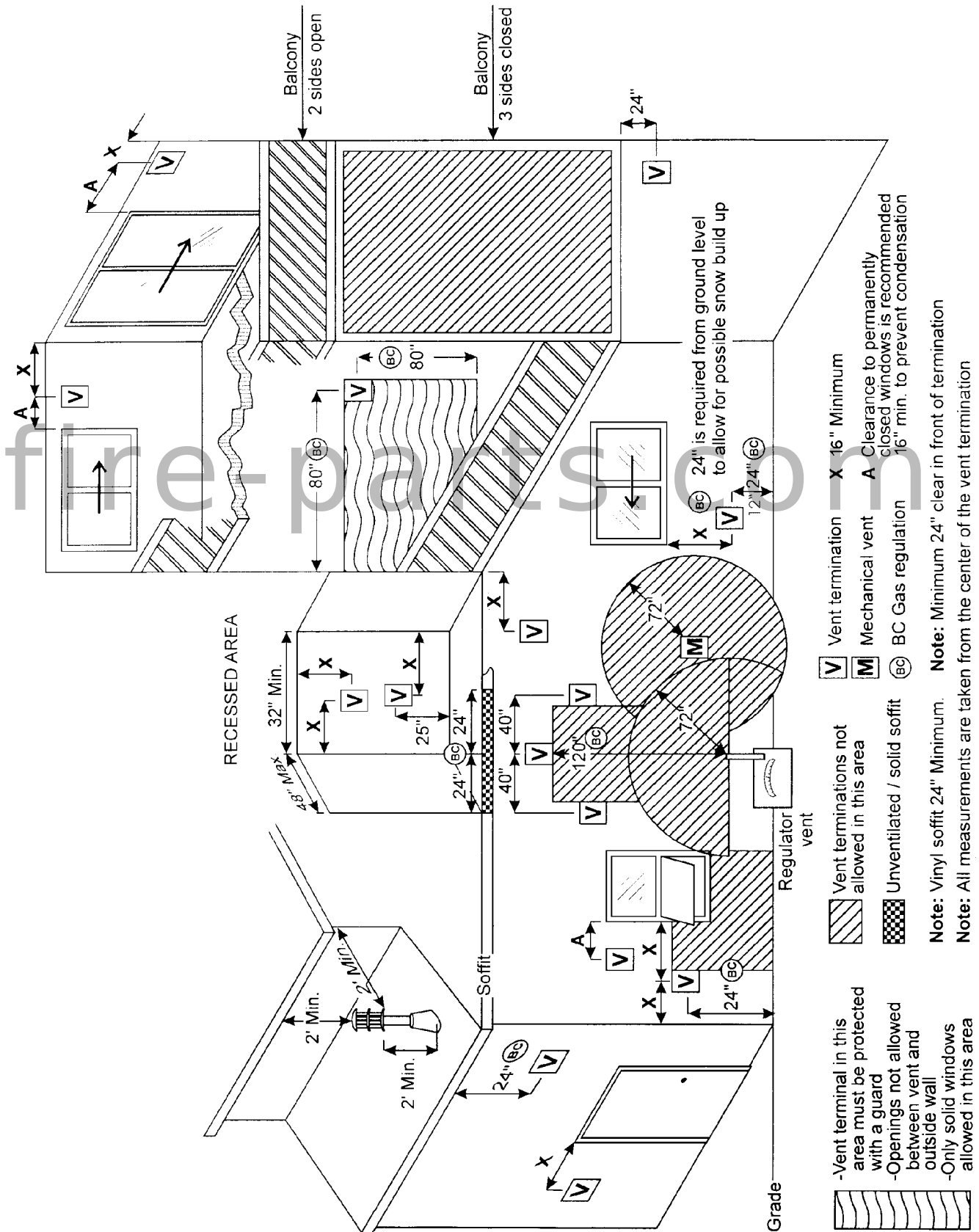

INSTALLATION INSTRUCTIONS Cont...

RESTRICTOR PLACEMENT



Restrictor Number 1



Restrictor Number 2

Archgard System

In the Archgard system the restrictors are placed on the exhaust outlet on the appliance.

Simpson Duravent

With Simpson Duravent the restrictors can be placed anywhere in the system. Locate the restrictor in the exhaust section fitting into the formed lip.



Simpson Duravent

Restrictor Placement



Archgard System

APPROVED VENT COMPONENTS

PART #	DESCRIPTION
TVK-FS1	Vent Kit with 36" vertical vent length (includes TK1)
TVK-FS2	Vent Kit with 48" vertical vent length (includes TK1)
TK-1	Horizontal termination head only
VSD-1	Vinyl siding deflector
C-1	Safety cage
SNK-24	24" Snorkel
SDA-1	Unit to Simpson Dura-Vent system adapter
BVA-45/55	"B" vent adapter
DV-GS	Simpson Dura-Vent venting system

INSTALLATION INSTRUCTIONS Cont...

STANDARD VENT KIT ASSEMBLY (TVK-FS1 & TVK-FS2)

NOTES: This Vent Kit must be installed directly onto the flue outlet of the heater. Maintain a minimum of 1" (25mm) sides and bottom, and 2" (51mm) from the top surfaces of the horizontal vent. Use the vent spacers shown on the Figure below. between the inner and outer vents at 3 ft (900mm) intervals. Maintain at least a 1/4" (7mm) rise for every 1' (300mm) horizontal vent. Use the included pipe joint compound and 3 self tapping screws at every vent connection.

1. Locate where the vent will pass through the wall, and cut and frame an 10" (254mm) wide x 11" (280mm) high hole.
2. Apply pipe joint compound on the 4" (100mm) crimp end of the vent cap and slip on one end of the flex vent. Fasten with 3 self tapping screws.
3. Place the horizontal section of the 7" (180mm) diameter rigid pipe over the flex vent so that the non-crimped end fits over the corresponding crimped end on the vent cap, and screw it in place.
4. Check the thickness of the wall and cut the 10" (250mm) dia x 12" (300mm) pipe to the thickness of the wall.
5. Place the 10" (250mm) dia pipe (thimble) over the other two, and screw it onto the standoffs of the termination.
6. From the outside, pass the vents and the thimble through the hole so that the 2" (51mm) standoff is on the top.
7. Screw the vent cap to the wall using the 2" (51mm) screws.
8. From the inside, place the firestop over the pipes, so that the standoffs fit into the hole and screw it in place using the 1-1/4" (32mm) screws. Seal with silicone sealer around pipe.
9. Similarly place the decorative trim collar over the firestop and screw it in place with 1-1/4" (32mm) screws.
10. Install the 1" (25mm) diameter spring spacers, elbow, and vertical rigid pipe as shown.
11. Move the heater into place and screw the flex, then the rigid pipe onto it's collars .

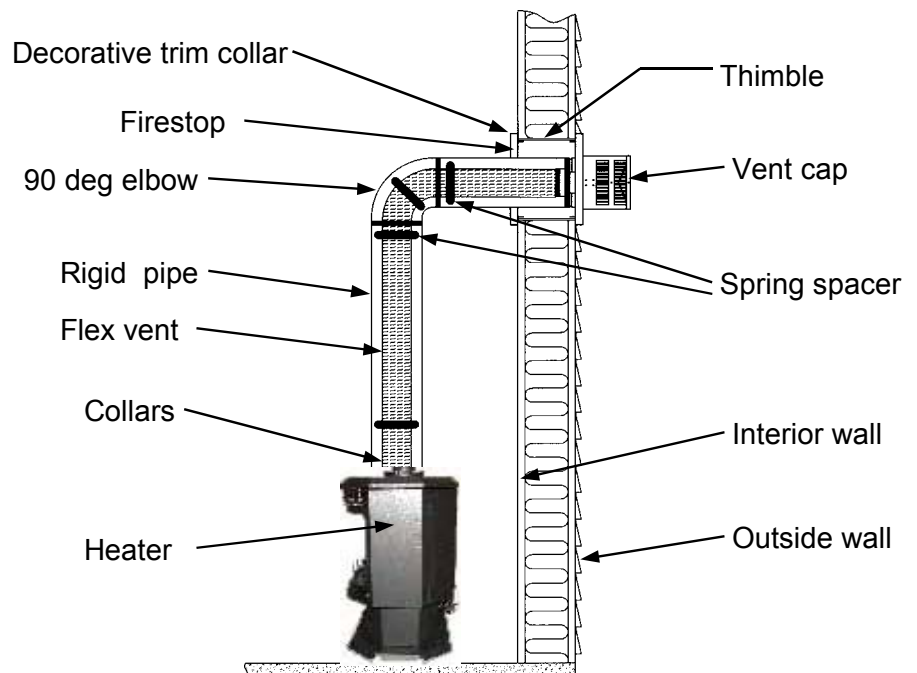
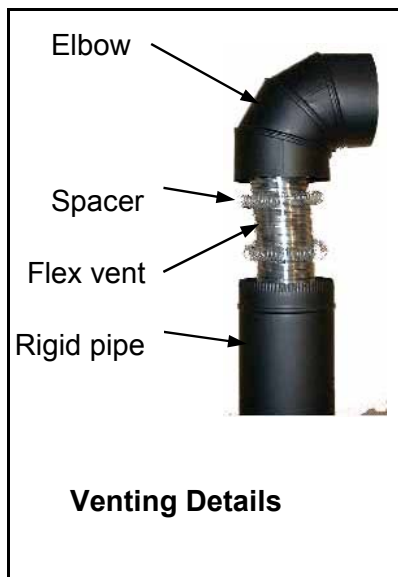

INSTALLATION INSTRUCTIONS Cont...

"B" VENT ADAPTER INSTALLATION (BVA-45/55)

This adapter will convert the Optima 45 direct vent heater into a "B" vent type heater. After installing this adapter, the venting needs to be installed according to the code for "B" vent appliances.

Tools required: Flat screw driver, 1/4" nut driver & Electric drill

NOTE: The Model BVA-45/55 adapter must be installed directly on the flue outlet of the heater. No pipe extensions are to be put in between. Draft openings must not be covered or blocked.

- Set the adapter firmly over the flue outlet with the spill switch facing directly toward the rear. Make sure it is vertical (check with level) and fasten with the 3 self drilling screws provided. Use nut driver and drill. (see photo 1)
- Run the spill switch wires under the top and behind the left door (see photo 2) and fasten with the wire clip as shown.
- Shine a light into the blower compartment and guide the wire through the same hole as the blower wire to the controls.
- Unscrew the control access door hinges and remove the 2 screws holding the control panel. Remove panel to expose the control valve.
- Remove the thermopile lead from the center valve terminal using the flat screw driver. Replace it with the forked terminal of the wire from the adapter (see photo 3)
- Slip the forked terminal just removed into the female connector on the other wire from the adapter. (You may need to bend the fork slightly smaller to fit into the connector).
- Replace panel and door in the reverse order they were removed.
- Listed 4" "B" vent or flex vent can now be installed. Surround the 4" vent with 7" "C" vent for protection and aesthetics. After installation, paint the pipe with "Stove-Brite New Metallic Black" to match.

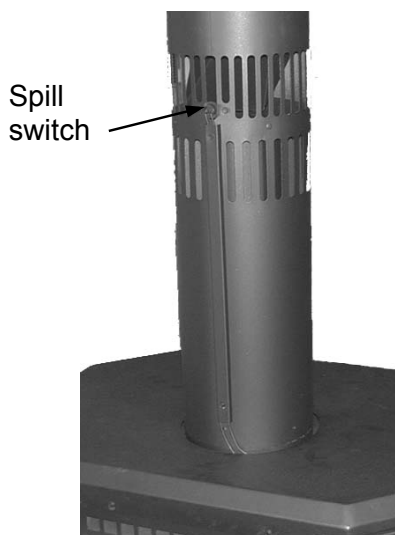
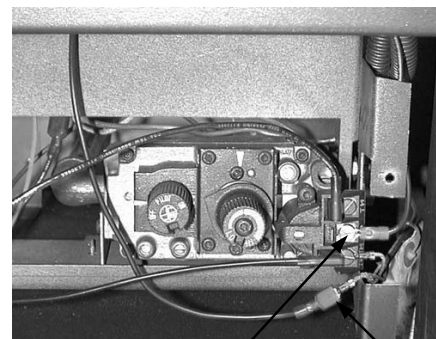

Photo 1



Photo 2



Middle terminal

Connect removed fork terminal here

Wire clip

Photo 3

INSTALLATION INSTRUCTIONS Cont...**GLASS DOOR****WARNINGS:**

- Do not attempt to remove the glass panel assemblies when the appliance is hot.
- Do not strike or abuse glass panels.
- Do not operate with glass panel broken or cracked.
- Broken or cracked glass panel assemblies must be replaced only with ones supplied by Archgard Industries.
- Do not use substitute materials or assemblies.
- Replacement of the glass should be carried out by a licensed or qualified service person.

Removing the Glass Door

To remove the glass door take the following steps:

- Open both side cover doors.
- Unlatch the right hand door catches.
- Swing the door open.
- Lift the door clear of the bottom hinge and drop out of the top hinge.

Replacing the Glass Door

- Reverse procedure of door removable.



To open the door
release the two
securing catches.

INSTALLATION INSTRUCTIONS Cont...**PLACEMENT OF LOGS AND BRANCHES**

- Locate the rear log on the locator pins and then the front log on it's pins. The branch fits over top as shown.

REAR LOG

BRANCH

FRONT LOG

**PLACEMENT OF EMBERS**

- A small bag of coals and embers are provided with the fireplace.
- Carefully place the coals and embers on the ledge between the grate and the front of the burner
- Do not allow the embers to obstruct the burner ports.

EMBERS &
COALS

WARNING: Do not place logs in any other configuration than that shown. Under no circumstances are logs to be modified.

OPERATION INSTRUCTIONS**FOR YOUR SAFETY, READ BEFORE LIGHTING****INITIAL OPERATION**

- Check that the appliance is properly vented and connected to the gas supply.
- Check that the logs and branches are properly placed.
- Check that all external parts, such as grills, door and faceplate are properly attached and fastened.
- Check that there are no finger prints left on gold surfaces as high temperature can bake these prints permanently.

NOTE : When operated for the first few times, the appliance will emit some odor and fumes. This is due to the heat from the appliance evaporating the oils and solvents used in fabricating the appliance. Close off the room to the rest of the house and open all windows. Keep the room well ventilated as smoke alarm may sound. Run the appliance for at least 4 hours at maximum setting with blower set to "OFF" to allow paint to cure.

WARNING : If you do not follow these instructions exactly, a fire or explosion may result, causing property damage, personal injury or loss of life. Do not operate the appliance with the glass front removed, cracked or broken. Replacement of the glass should be done by a licensed or qualified service person.

OPERATION INSTRUCTIONS Cont..

LIGHTING INSTRUCTIONS (copy of instruction plate found in control panel)

FOR YOUR SAFETY READ BEFORE LIGHTING

WARNING: If you do not follow these instructions exactly, a fire of explosion may result causing property damage, personal injury or loss of life.

- A. This appliance has a pilot which must be lighted by a spark ignitor. When lighting the pilot follow these instructions exactly.
- B. BEFORE LIGHTING smell all around the appliance area for gas. Be sure to smell next to the floor because some gas is heavier than air and will settle on the floor.
- WHAT TO DO IF YOU SMELL GAS
- Do not try to light any appliance.
 - Do not touch any electrical switch; do not use any phone in your building.
 - Immediately call your gas supplier from a neighbor's phone. Follow the gas supplier's instructions.
- C. Use only your hand to push in or turn the gas control knob. Never use tools. If the knob will not push in or turn by hand don't try to repair it, call a qualified service technician. Force or attempted repair may result in a fire or explosion.
- D. Do not use this appliance if any part has been under water. Immediately call a qualified service technician to inspect the appliance and to replace any part of the control system and any gas control which has been under water.
- If you cannot reach your gas supplier, call the fire department.

LIGHTING INSTRUCTIONS

1. STOP! Read the safety information above on this label.
2. Set the remote switch to "OFF". Set the thermostat to the lowest setting. (Only if your appliance is equipped with these devices.)
3. Turn off all electric power to the appliance.
4. Open lower louvers or access door.
3. Press slightly and turn the control knob clockwise \curvearrowright to the "OFF" position.
4. Wait 5 minutes to clear out any gas. Then smell for gas, including near the floor. If you smell gas, STOP! and follow instruction "B" above.
5. Find pilot. It is located between the logs near the center behind the burner.
6. Press slightly and turn control knob counterclockwise \curvearrowleft to "PILOT". Depress knob and light pilot by repeatedly pressing the sparker. Once flame is established, hold knob depressed for approximately 30 seconds. Release knob. If pilot should go out, repeat steps 3 to 5.
 - If the knob does not pop up when released, stop and immediately call your service technician or gas supplier.
 - If the pilot will not stay lit after several tries, turn the gas control knob to "OFF" and call your service technician or gas supplier.
7. If the appliance has a manual valve, turn gas control knob counterclockwise \curvearrowleft to the desired heat setting from If the appliance has an automatic valve, turn gas control knob counterclockwise \curvearrowleft to "ON" and set the flame adjustment knob to the desired heat setting from "LO" to "HI".
8. Set the remote switch to "ON". Set the thermostat to the desired setting. (Only if your appliance is equipped with these devices.)
9. Turn on all electric power to the appliance.
10. Close louver or access door.

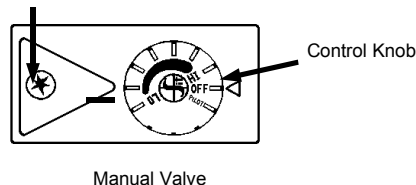
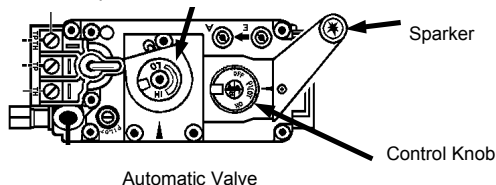

Pilot

TO TURN OFF GAS TO APPLIANCE

1. Set the thermostat to the lowest setting and turn the remote switch to "OFF".
2. Turn off all electric power to the appliance if service is to be performed.
3. Open lower louvers or access door.
4. Press slightly and turn control knob clockwise \curvearrowright to "OFF". Do not force.
5. Close lower louvers or access door.

MAINTENANCE

CAUTION : Do not conduct maintenance on the appliance while it is operating or while it is still hot.

CLEANING THE APPLIANCE

The exterior painted surfaces, glass and gold trims may be cleaned with a soft, non-abrasive cloth and water or a suitable, mild, non-abrasive cleaner.

Regularly:

- Clean and remove any lint accumulations or debris from the grills and in any combustion and convection air passage ways.
- Keep the appliance area free from combustible materials, such as paper, wood, clothing, gasoline and flammable solids, liquids and vapors.
- Visually check the height and color of the burner and pilot flames.

Every 2 to 3 months:

- Remove the glass door and clean the inside of the glass with a soft, non-abrasive cloth and water or a suitable, mild, non-abrasive cleaner. **DO NOT CLEAN WHILE HOT.**
- Carefully remove the logs and gently brush off any loose carbon deposits. This job is best done outside the house, wearing a dust mask. The logs are very fragile, take care not to break them. **Do not wash logs with any liquid.** While logs are removed, also remove the coals and “embers” and check that all burner openings are not obstructed. It is recommended you use a vacuum cleaner to clean off any dust or lint.
- After cleaning, the logs, coals and embers must be replaced as per the instructions in this manual.

Once a Year have a qualified service technician:

- Completely inspect the appliance and the venting system. Vent connection can be checked by removing the vent baffle in the firebox. Remove the 5 — 1/4 hex head screws holding the baffle. Replace baffle after inspection.
- Clean and remove any lint accumulations or debris in the firebox, on the burners, on the pilot, at the primary air opening, on the convection air blower and in any combustion and convection air passage ways.
- Check the safety system of the gas valve and the appliance.

WARNING : All parts removed or disturbed including guards and grilles must be properly replaced after maintenance. Service and repair must be conducted by a qualified service person. If these instructions are not followed, a fire or explosion may result, causing property damage, personal injury or loss of life.

TROUBLE SHOOTING

Please check to make sure the instructions are followed exactly before attempting trouble shooting of the appliance.

WARNING: Trouble shooting and servicing of gas and electrical devices of the appliance should only be conducted by a qualified service technician.

SYMPTOM	ACTION
Pilot will not light after pressing the sparker many times.	<ol style="list-style-type: none"> 1. When lighting the appliance for the first time after installation or after servicing, there is air in the gas line. It takes a while for all the air to purge out of the pilot before gas can reach the pilot and ignite. Remove the glass door and try lighting the pilot many times to purge the air. 2. Check to make sure the gas supply to the appliance is turned on and there is adequate gas supply pressure to the appliance. 3. Check for sparks between the spark electrode and the pilot head when the sparker is pressed. If there are no sparks, <ol style="list-style-type: none"> a. Check for broken or poor connection from the sparker to the electrode. b. Check for the spark shorting or arcing at other locations. c. Check for defective sparker. d. Check for defective spark electrode. 4. With the door removed, try lighting the pilot with a match. <ol style="list-style-type: none"> a. If air is blowing on the flame of the match, hold the control knob in at the 'PILOT' setting until all the air is purged out of the line. b. If there is no gas or air coming out of the pilot and there is gas pressure to the appliance, the pilot orifice may be blocked or the gas valve may be defective.
Pilot will not remain on after being lit.	<ol style="list-style-type: none"> 1. Press the control knob all the way in. 2. Hold the control knob in for a longer period of time. 3. If you are trying to re-light the pilot immediately after you have shut-off the pilot, you have to wait 5 minutes for the valve to reset. 4. Check to see if the pilot flame is large enough to reach and surround the thermocouple. If the flame is too small, check for correct gas supply pressure. If pressure is good, adjust the pilot flame size with the adjustment screw on the valve. If the flame cannot be adjusted, there might be some debris obstructing the pilot orifice, or a wrong size pilot orifice. 5. Check for poor connection of the thermocouple to the valve. 6. Check for proper millivolts of the thermocouple. The thermocouple should generate at least 30 mV or it is defective. 7. Check for defective gas valve.
The main burner does not turn on with the pilot lit.	<ol style="list-style-type: none"> 1. Check to make sure the control knob is turned to the 'ON' position. 2. Allow enough time for the pilot to heat up the thermopile to generate sufficient voltage to activate the valve.

TROUBLE SHOOTING Cont...

SYMPTOM	ACTION
The main burner does not turn on with the pilot lit. Cont...	<ol style="list-style-type: none"> 3. Check to make sure the thermostat is set high enough to turn on the appliance. 4. Check that the remote switch or the thermostat is turned on. 5. Check for weak pilot flame. If flame is weak, check gas supply, check pilot flame adjustment and check for blockage of pilot orifice. 6. Check all connections to the valve for tight electrical contact. 7. Check spill switch for continuity. 8. Check for 400-500 mV from the thermopile with the burner off and 200-250 mV with the burner on. If the voltages are lower, the thermopile is defective. 9. Check for defective gas valve.
The main burner shuts off when the appliance is warm.	<ol style="list-style-type: none"> 1. This may be the normal operation of a wall thermostat installed to appliances. 2. Check for good pilot flames on the thermopile (see page 22). 3. Check for good voltage from the thermopile. 4. Check for proper functioning of venting system. 5. Check wire connections. Expansion from heat affects a loose connection
Sooty deposits on the glass door.	<ol style="list-style-type: none"> 1. If the flame is yellow and lazy, check for lint etc. around primary air shutter. Increase primary air by opening the primary air shutter if necessary. 2. Check for proper placement of the logs and branches. Ensure logs and burner are clean. See that section in the instruction manual. 3. Check for obstruction of the burner ports by the embers. See that section in the instruction manual. 4. Check for proper venting and blockage of the vent termination. 5. Check manifold pressure and clock input rating for over-firing.
Sharp blue flames with flames lifting off the burner at the ends.	<ol style="list-style-type: none"> 1. Too much primary air. Reduce primary air by closing the primary air shutter. During cold temperatures, some flame lifting may occur during start-up.
Convection blower does not turn on.	<ol style="list-style-type: none"> 1. The convection fan is thermostatically controlled. It will only turn on when the appliance is warmed-up. This may take up to 15 minutes with the appliance on high. 2. Check for 120 VAC electrical supply to the appliance. (Is the cord plugged in?) 3. Check for proper mounting of the thermal snap disc. 4. Check electrical connections. 5. Check for defective thermal snap disc. 6. Check for defective convection blower speed controller. 7. Check for defective convection blower.

WIRING DIAGRAMS

VALVE CONNECTIONS

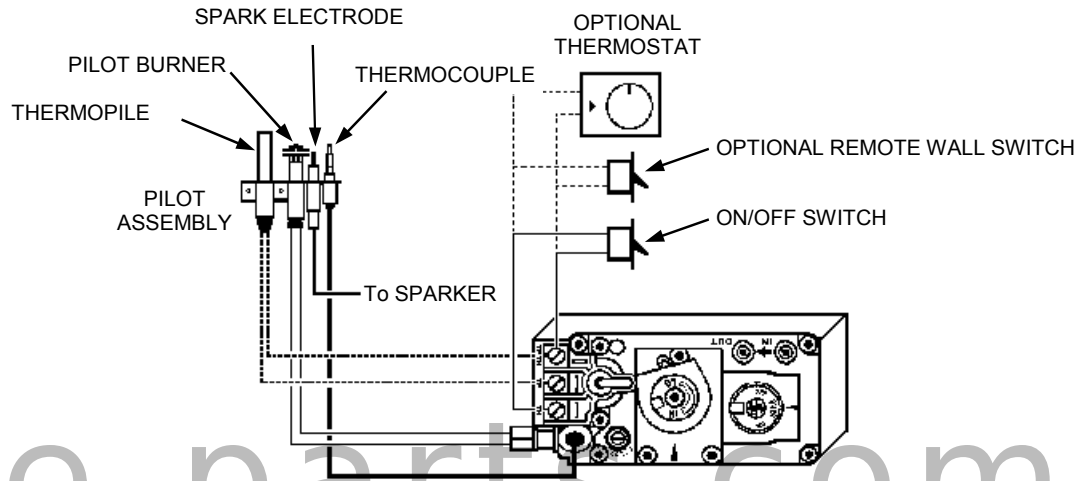

fire-parts.com

SERVICING

SERVICING UNDER WARRANTY

Before servicing, read the terms and conditions of the Archgard warranty at the back of the manual. Contact the Archgard authorized dealer which you have purchased the appliance from and provide him with details of the problem and the installation information which the installer has fill out at the back of the manual.

WARNING: Servicing of this appliance **must be conducted by a qualified service technician.** Improper servicing, adjustment or alteration of this appliance may cause property damage, personal injury or loss of life. All servicing should be conducted with the appliance cold. All replacement parts must be authorized by Archgard for suitability.

ADJUSTING PRIMARY AIR

Note: the Shutter is set at the factory and normally only requires setting at higher altitudes.

- Open the lower grilles.
- Unscrew the 2 screws holding the blower speed control panel and remove the panel.
- The primary air adjustment wing nut is located behind and to the left of the control valve.
- Loosen the wing nut and slide the primary air shutter to the right to increase primary air and to left to reduce primary air.
- Tighten the wing nut after adjustment.
-

Caution: Wear gloves when adjusting the primary air with the appliance hot.

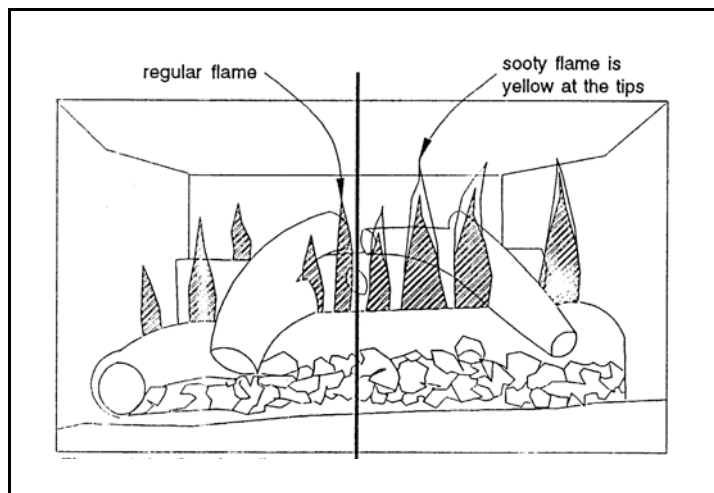
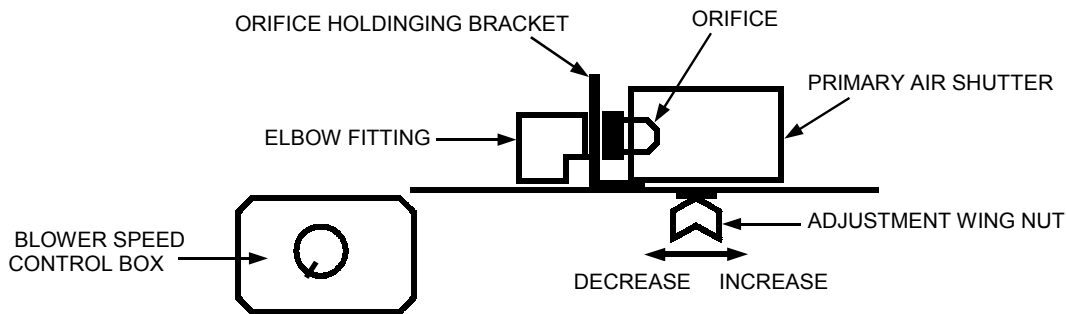

FLAMES...

The left side shows correct adjustment. The right side shows yellow sooty flames requiring increase in shutter opening or cleaning of shutter area due to lint buildup.

SERVICING Cont...

CHANGING MAIN BURNER ORIFICE

- Remove the glass door, log branches and the front log.
- Unscrew the 3 screws holding the burner shield between the burner tubes and remove the shield and lift out the burner.
- Remove the adjustment wing nut and slide the air shutter away from the orifice cap.
- Use a 1/2" wrench to remove the orifice cap.
- Change the orifice cap. Use a small quantity of gas thread seal compound. Do not over tighten.
- Replace the adjustment wing nut and properly set the primary air shutter according to the specifications.
- Replace the burner, shield, front log, branches and the glass door.

CHECKING INLET AND OUTLET GAS PRESSURE

- Open the lower grills.
- The pressure test taps are located on the valve.

Automatic valve: The taps are located in the front. The inlet is marked 'IN' and the outlet is marked 'OUT'. There is also an arrow marking the direction of gas flow.

Manual valve: The taps are located on the left side of the valve. The connection closest to the back, marked with 'IN' is the inlet and the outlet marked with 'OUT' is closest to the front.

- Loosen the set screw inside the tap with a 1/8" wide flat screw driver.
- Connect a 1/4" rubber tube to the tap and to the manometer.
- Be sure to tighten the set screw inside the tap after you are finish taking pressure readings.
- Check for leaks.

CHECKING AND ADJUSTING PILOT

The pilot flame should have the characteristic as shown in the illustration below. The flame should not have yellow tips but should engulf the thermocouple and thermopile. It can be adjusted by turning the screw marked "pilot" on the control valve.

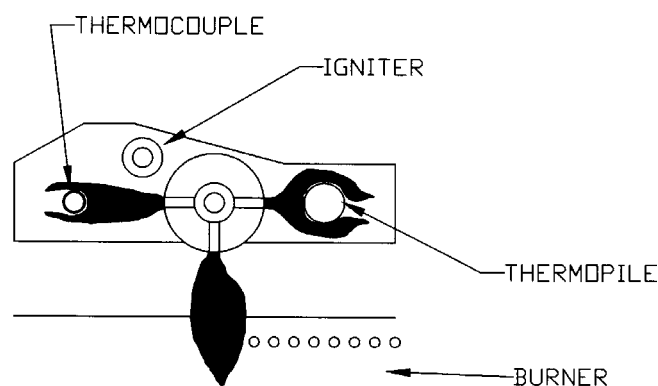

SERVICING Cont...

REPLACING PILOT ORIFICE

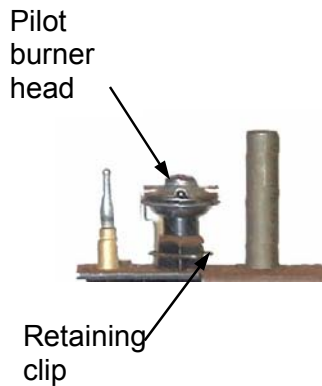

The pilot orifice sits underneath the pilot burner head. Remove the head just by pulling it off. You may have to wiggle it a bit. **DO NOT REMOVE THE RETAINING CLIP.** Use a 5/32 Allen wrench to remove the orifice. Replace in reverse order. There is a notch in the head to line it up correctly on replacement. Ensure the head is pushed down all the way.

WHEN YOUR GLASS BREAKS

In the event your glass cracks or breaks, it must be replaced by the exact same size and material. It is made from high temperature ceramic material. See replacement parts list and contact your nearest Archgard dealer.

- Remove door and remove the 3 screws on each side of the door. Remove rope gasket and pull out inner frame.
- Carefully remove all traces of glass and gasket material.
- Replacement requires ceramic glass part #307-0035 or 307-0036, gasket part #314-0004 AND #314-0005 and sealer part #319-0005.
- Install new glass with new gasketing (#314-0004) in place. Replace the frame and hold in place with the 6 screws.
- Replace the 1" rope gasket with a new material (#314-0005). Hold in place using the sealer.
- Replace the door carefully making sure both clamps are closed.

REPLACING CONVECTION BLOWER

- Disconnect power to the gas appliance.
- The convection blower is located at the back of the appliance. Remove the six screws holding the blower mounting plate to the back of the appliance.
- Carefully withdraw the blower from the back of the appliance.
- Disconnect the wires from the blower.
- Remove the three screws holding the blower to the mounting plate.



Replacement Parts for OPTIMA 45

Item #	Item Description	Qty	Unit
200-0048	OWNER'S MANUAL, OPTIMA 45	1	EA
300-0029	HINGE, 1" X 1" BUTT HINGE FLUSH	4	EA
300-0031	MAGNET .25 X .875 X 1.0 7# PULL	4	EA
300-0055	LATCH CLAMP FTNER C/W THRD J HOOK C/W	2	EA
301-0038	ORIFICE, CAP #37	1	EA
301-0039	ORIFICE, CAP #52	1	EA
305-0013	SPEED CONTROL KBMS - 13BV C/W KNOB	1	EA
305-0015	ELECTRIC FAN - CROSSFLOW 115 V FAN LH	1	EA
305-0019	SWITCH ROCKER CARLING RA911-VB-B-1VXAG1	1	EA
305-0021	THERMODISC 110 DEG FAN SWITCH	1	EA
307-0035	GLASS, CERAMIC 12 x 16.5 (OI45)	1	EA
307-0036	GLASS, CERAMIC 4.688 x 12 (OI45)	2	EA
308-0005	PIEZO IGNITOR C/W NUT (JBS), 66270-003	1	ea
308-0012	VALVE, SIT NOVA MV HI-LO (LP)	1	ea
308-0013	VALVE, SIT NOVA MV HI-LO (NG)	1	EA
308-0046	KNOB EXTENSION ON/OFF 1 1/2"	1	EA
308-0047	KNOB EXTENSION HI/LO 1 1/2"	1	EA
308-0054	PILOT ASSEMBLY, CONVERTIBLE PILOT LP SIT	1	EA
308-0055	PILOT ASSEMBLY, CONVERTIBLE PILOT NG SIT	1	EA
310-0009	COALS, MEDIUM GRADE 4OZ BAG	1	EA
310-0046	MINERAL WOOL, "EMBERS"	1	OZ
310-0061	LOG, REAR OPTIMA 20/30/45	1	EA
310-0062	LOG, FRONT OPTIMA 20/30/45	1	EA
310-0063	LOG, TWIG OPTIMA 20/30/45	1	EA
311-0032	BRICK LINER, OPT 45 REAR (722-0037)	1	EA
311-0033	BRICK LINER, OPT45 RH SIDE (722-0038)	1	EA
311-0034	BRICK LINER, OPT 45 LH SIDE (722-0038)	1	EA
314-0004	GASKET GF - FLAT .197 X .875 ER55/OI45	90	IN
314-0005	GASKET WHITE 1" FIBREGLASS SOFT ROPE	80	IN
314-0101	GASKET, RELIEF PLATE 3.5 X 15 (736-0040)	1	EA
314-0121	GASKET, VALVE TRAY OI45 (722-0042)	1	EA
317-0001	BURNER, U TUBE TYPE OI-30 (701-0001)	1	EA
317-0025	SPACER ALUM. CONTROL DOOR HINGE(714-0057	2	EA
317-0028	TOP LOUVER ASSEMBLY FOR OPT45 (800-0056)	1	EA
317-0029	BOTTOM LOUVER ASSEMBLY FOR OP45(800-0057	1	EA
722-0007	STOVE TOP	1	EA
800-0020	ELECTRIC CORD ASSEMBLY	1	EA

Parts can be ordered through your local dealer or distributor by giving ITEM # and DESCRIPTION.

**ARCHGARD LIMITED WARRANTY**

This Limited Warranty is made by ARCHGARD INDUSTRIES LTD. hereinafter referred to as "Archgard". Archgard warrants to the original consumer that the gas burning fireplaces will be free from defects in materials and workmanship under normal use and service, for a lifetime.

INCLUSIONS:

- Combustion chamber, thermal damage (ceramic glass breakage), burner pans & burner tubes, log sets (including embers & brick panels) and all gold plating.
- Electrical components and gas valves are covered under the warranty for a period of 1 year from purchase.

EXCLUSIONS:

- Paint, trim, gasket, parts which have been tampered with or modified in any way.
- Negligence, misuse, accidental damage.
- Special environmental conditions, which may cause spillage or downdraft conditions due to negative room air pressure, geographical location, inadequate ventilation or excessive offsets.

WHAT TO DO IN THE EVENT OF A PROBLEM:

- Thoroughly read your manual.
- If you cannot solve the problem yourself contact your Archgard dealer or representative.
- When calling for help have the following information available:

Model Name

Serial Number

Place of Purchase

Date of Purchase

Problem Description

NOTE: Warranty may be void if work is carried out by unqualified personnel. Only original Archgard parts may be used. Please consult your Archgard representative if in doubt.

OBTAINING WARRANTY SERVICE:

To obtain warranty service, the consumer shall return the defective part to the original selling dealer transportation prepaid, along with the serial number of the appliance and proof of purchase. Any defective part, in our judgment, will be repaired or replaced at Archgard's discretion. The dealer must obtain approval from an authorized Archgard representative before any repairs are made.

WARRANTY LIMITATION:

THIS LIMITED WARRANTY IS MADE IN LIEU OF ALL OTHER WARRANTIES, EXPRESSED OR IMPLIED AS TO QUALITY, MERCHANTABILITY OR FITNESS FOR PARTICULAR PURPOSE.

The appliance is only warranted for the use as intended by the installation and operating instructions and local building codes. The warranty will not cover damage due to accident, misuse, abuse, alteration or improper installation.

This limited warranty is void unless the appliance is installed by a qualified installer, in accordance with the instructions furnished with the appliance. Some Provinces or States do not allow limitations on how long an implied warranty lasts, so the above limitation may not apply to the consumer.

Any damages resulting from defects in this product, is limited to replacement of defective parts and does not include incidental and consequential expenses sustained in connection with the product. This warranty is limited to residential use only and gives the consumer specific rights. These rights may vary from State to State or Province to Province.