



# OPTIMA 70 - 1

DIRECT VENT  
GAS FIREPLACE

FOR USE WITH NATURAL GAS OR  
PROPANE



## USERS

## INSTALLATION

## OPERATION & MAINTENANCE MANUAL

**WARNING:** If the information in this manual is not followed exactly, fire or explosion may result causing property damage, personal injury or loss of life.

— Do not store or use gasoline or other flammable vapors and liquids in the vicinity of this or any other appliance.

— **WHAT TO DO IF YOU SMELL GAS**

- Do not try to light any appliance.
- Do not touch any electrical switch; do not use any phone in your building.
- Immediately call your gas supplier from a neighbor's phone. Follow the gas supplier's instructions.
- If you cannot reach your gas supplier, call the fire department.

— Installation and service must be performed by a qualified installer, service agency or the gas supplier.

**Installer: Please leave this manual with the appliance owner for future reference**



7116 Beatty Dr  
Mission, BC V2V 6B4  
Canada



200-0051

18MAY01

# CONTENTS

<b>Introduction</b>	<b>3</b>
<b>General Information</b>	<b>4</b>
<b>Appliance Description</b>	<b>5</b>
<b>Dimensions and Clearances</b>	<b>6</b>
<b>Installation Instructions</b>	<b>7—18</b>
<b>Operation Instructions</b>	<b>19—20</b>
<b>Maintenance</b>	<b>21</b>
<b>Trouble Shooting Instructions</b>	<b>22—23</b>
<b>Wiring Diagrams</b>	<b>24</b>
<b>Servicing</b>	<b>25—27</b>
<b>Replacement Parts</b>	<b>28</b>
<b>Warranty</b>	<b>29</b>

## CAUTION

Due to high temperatures, the appliance should be located out of traffic and away from furniture and draperies.

Children and adults should be alerted to the hazards of high surface temperature and stay away to avoid burns or clothing ignition.

Young children should be carefully supervised when they are in the same room as the appliance.

Clothing or other flammable material should not be placed on or near the appliance.

Do not operate this appliance with the glass front removed, cracked or broken. Be careful not to strike or slam the glass. Replacement of the glass should be done by a licensed or qualified service person.

Installation and repair must be done by a qualified service person. Any parts removed or opened for servicing of the appliance must be properly replaced prior to operating the appliance.

The appliance must be inspected before use and at least annually by a qualified service person. More frequent cleaning maybe required due to excessive lint from carpeting, bedding material, etc. It is imperative that the control compartments, burners and circulating air passageways for the appliance be kept clean.

Patents Pending

INTRODUCTION

Congratulations for choosing an Archgard fireplace.

The Optima 70 is one of the most advanced direct vent fireplace heaters available. It is solidly designed using the latest technology and manufactured to the highest quality. It is our aim to provide you an appliance with many trouble free years of reliable service.

The following are just some of the many features within your new gas fireplace:

- Heater Classification The Optima 70 is classified as a heating appliance. Therefore, it has additional safety devices built-in and it can be operated continuously for zone heating.
- High Efficiency The Optima 70 has one of the highest efficiencies of any gas fireplace; which means that it is less expensive to operate.
- Adjustable Fan Speed Heat circulation fan can be fully adjusted from high, medium or low speeds to suit your comfort level.
- Adjustable Flame The flame aesthetics and heat output can be adjusted to suit your heating needs and the season.
- Solid Construction The Optima 70 is constructed mainly of 14 and 18 gauge galvanized and aluminized steel for long life and durability.
- Optional Thermostatic Control The gas control system is "thermostat" ready for any millivolt wall thermostat or wireless remote control

Please read the manual carefully prior to installation and operation of the appliance. Proper installation, operation and maintenance of the appliance will provide you with many years of enjoyment. We recommend you record the following information:

Fireplace Model Number \_\_\_\_\_

Fireplace Serial Number \_\_\_\_\_

Date of Installation \_\_\_\_\_

Type of Gas Used by the Fireplace \_\_\_\_\_

Dealer's Name \_\_\_\_\_

\_\_\_\_\_

## GENERAL INFORMATION

### APPLIANCE SAFETY APPROVALS AND CERTIFICATION

This appliance is tested and safety approved under the following US and Canadian gas appliance standards:

- ANSI Z21.88a-1998/CSA 2.33a-M98, Vented Gas Fireplace Heaters,
- ANSI Z21.44-1995, CAN1-2.19-M81, Direct Vent Wall Furnaces
- CAN/CGA-2.17-M91, Gas-Fired Appliances for Use at High Altitudes

Please contact Archgard Industries Ltd., if you have any questions regarding the certification of this appliance.

### INSTALLATION CODES

This appliance must be installed by a qualified gas appliance installer.

The installation must conform with the local codes or, in the absence of local codes, with the current National Fuel Gas Code, ANSI Z223.1/ NFPA 54, in the US or Installation Code, CAN/CGA-B149, in Canada. Electrical connections and grounding must conform with local code, or current National Electrical code, ANSI/NFPA No. 70-1987, in the US and in Canada, the current Canadian Electrical Code, CSA C22.1.

### SPECIFICATIONS

	Natural Gas (NG)	Propane (LP)
<b>Manifold Pressure</b>	0.9-3.5 in. W.C. (0.2-0.9 kpa)	3.6-10.0 in. W.C. (0.9-2.5kpa)
<b>Min. Supply Pressure for Purpose of Input Adjustment</b>	4.5 in. w.c. (1.2 kPa)	11.0 in. w.c. (2.8 kPa)
<b>Orifice Size</b>	#37 DMS (2.66mm dia.)	#51 DMS (1.70 mm dia.)
<b>Nominal Input Rating</b>	30,000 - 15,000 BTU/hr ( 8.8 - 4.4 kW)	30,000 - 18,000 BTU/hr (8.8 - 5.3 kW)
<b>Output (Fan On) @ Max. Rating</b>	22,500 BTU/hr (6.9 kW)	23,100 BTU/hr (6.9 kW)
<b>Output (Fan Off) @ Max. Rating</b>	22,500 BTU/hr (6.9 kW)	23,100 BTU/hr (6.9 kW)
<b>Altitude</b>	0-4500 ft (0 - 1370 m)	0 - 4500 ft (0 - 1370 m)
<b>Primary Air Opening</b>	1/8 in. (9.6 mm)	3/8 in. (9.6 mm)

### HIGH ALTITUDE INSTALLATION

When installing this appliance beyond 4500 ft. (1372 m) above sea level. The appliance must be properly de-rated and installed according to local codes, in the absence of local codes, with the current National Fuel Gas Code, ANSI Z223.1/ NFPA 54, in the US or Installation Code, CAN/CGA-B149, in Canada.

**APPLIANCE DESCRIPTION**

**FLAT FRONT VERSION**

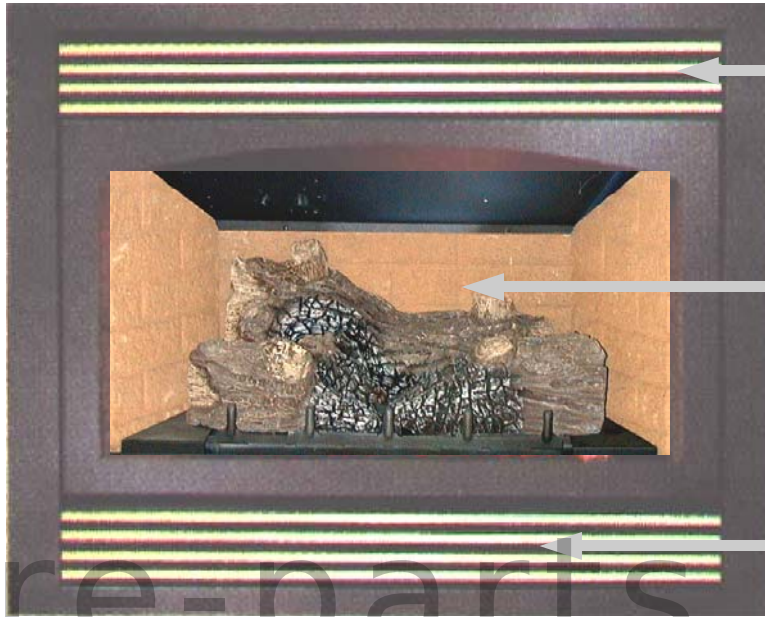

Top Louvers

Ceramic Viewing Glass

Hinged Bottom Louvers. Swing open to access controls.

fire-parts.com

**BAY FRONT ADDED**

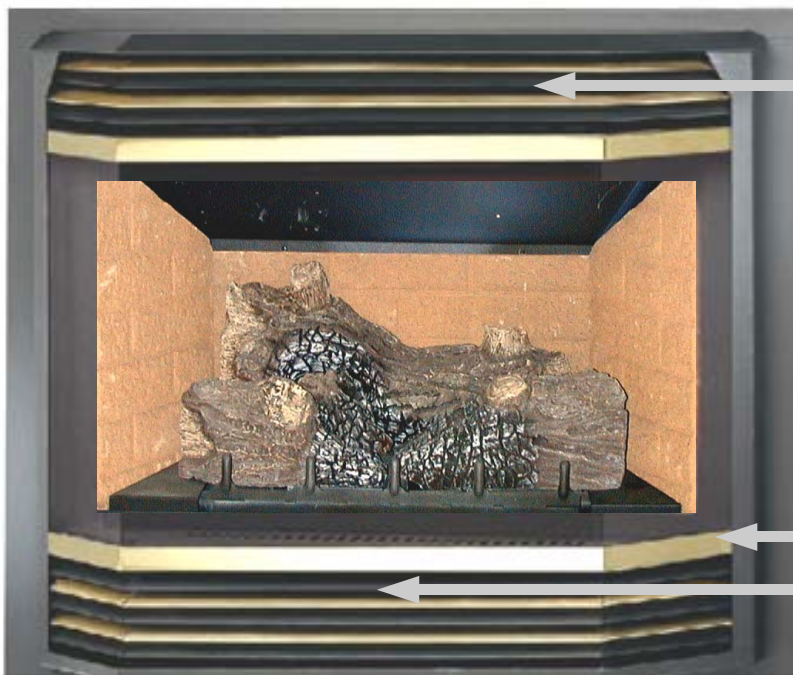

Alternating black / gold louvers

Optional gold trim

Control access door

**DIMENSIONS AND CLEARANCES**

**APPLIANCE DIMENSIONS**

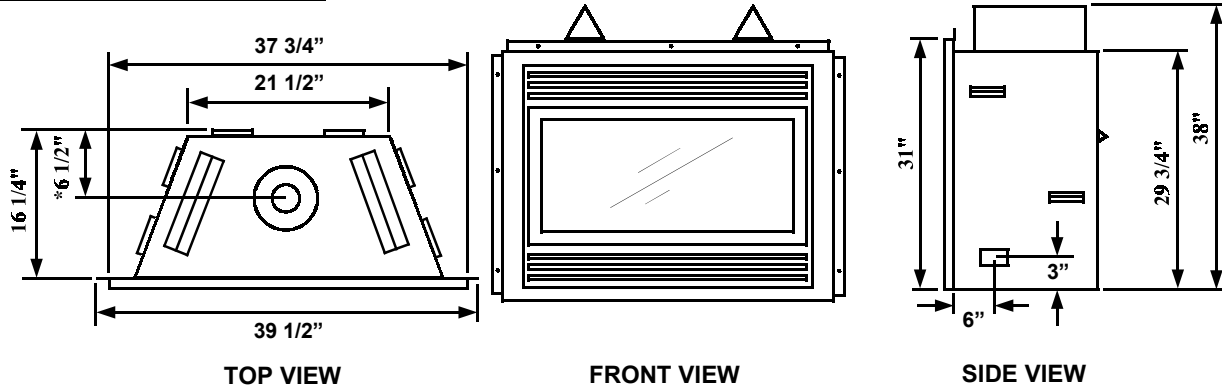

**CLEARANCES TO COMBUSTIBLES:**

BACK	0" to stand-offs
SIDES	0" to stand-offs
TOP	0" to stand-offs
BOTTOM	0"
ADJACENT SIDE WALL	1" to side of faceplate
MANTLE	see diagram
VENT	1" to outside side and bottom surface, 2" to outside top surface.

**MANTLE CLEARANCE**

Combustible mantle allowed in shaded area. Mantle extension may be increased 1" (25mm) for each additional 1" (25mm) increase in clearance height.

Low profile wooden crowns and moldings above the unit are not considered as mantles. I.E. 1" or less protrusions on the upper mantle facing are acceptable

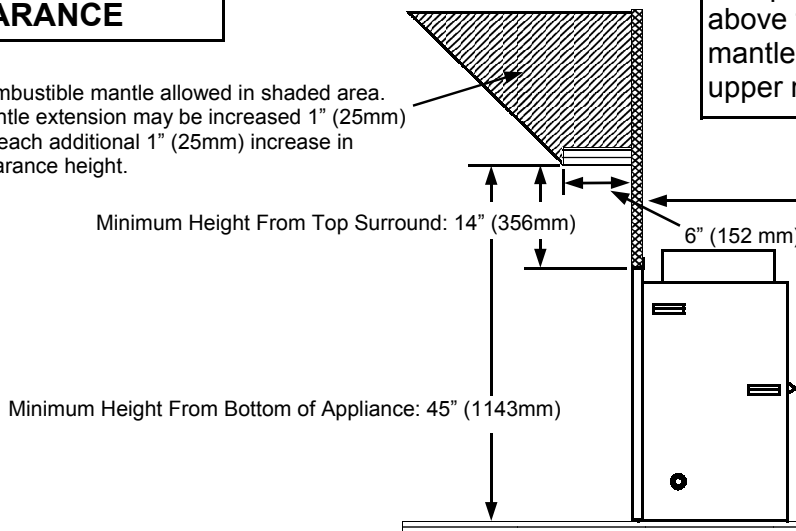

## INSTALLATION INSTRUCTIONS

### PRECAUTIONS

- This appliance must be installed by a qualified gas installer and the installation must conform to the installation codes.
- Provide adequate clearance around air openings of the appliance. Never obstruct front openings.
- Provide adequate clearances for proper operation and servicing of the appliance.
- This appliance must be properly connected to a venting system.
- This gas appliance must not be connected to a chimney serving a separate solid-fuel burning appliance.
- Do not use this appliance if any part has been under water. Immediately call a qualified service technician to inspect the appliance and to replace any part of the control system and any gas control which has been under water.
- **Caution:** Label all wires prior to disconnection when servicing controls. Wiring errors can cause improper and dangerous operation.
- Verify proper operation after servicing.
- Do not use substitute materials.
- Do not abuse glass doors by striking or slamming shut.
- Do not use abrasive cleaners.
- Use only approved fireplace glass cleaner for cleaning your glass.

### LOCATING GAS FIREPLACE

This appliance must be installed in any location that is free of plumbing, electrical wiring and heating or air conditioning ducts. Select a location that is accessible for venting. See ALLOWABLE TERMINATION LOCATIONS ON PAGE 12.

### GAS CONNECTIONS

Have your gas supplier or a qualified gas fitter run a gas supply line into the fireplace. The line must be properly sized and fitted according to the installation codes. Immediately up stream of the supply connection, the fitter shall provide an accessible manual shut-off valve and a 1/8 NPT plugged tapping accessible for connection to a test gauge.

**CAUTION:** The appliance and its individual shutoff valve must be disconnected from the gas supply piping system during any pressure testing of that system at test pressures in excess of 1/2 psig (3.5 kPa). The appliance must be isolated from the gas supply piping system by closing its individual manual shutoff valve during any pressure testing of the gas supply piping system at test pressures equal to or less than 1/2 psig (3.5 kPa). Failure to do so will damage the appliance's gas valve. Such damage is not covered by the manufacturer's warranty.

## INSTALLATION INSTRUCTIONS

### Natural Gas Pressure Settings:

The inlet supply or line pressure must be a minimum of 4.5" wc (1.1 kPa) and a maximum of 8" wc (2 kPa). The orifice has a #37 DMS orifice.

<u>ELEVATION</u>	<u>INPUT RATING</u>
------------------	---------------------

0-4500 ft. (0-1400 m)	30,000 BTU/hr (8,800 watts)
-----------------------	-----------------------------

4500 ft. (1400 m) +	30,000 BTU/hr (8,800 watts) less 4% per 1000 ft. (300 m)
---------------------	--

Please contact your local utility or distributor for the appropriate orifice size you require.

### Propane Pressure Settings:

The inlet supply or line pressure must be a minimum of 11" wc (2.8 kPa) and a maximum of 14" wc (3.5 kPa). The orifice has a #53 DMS orifice.

<u>ELEVATION</u>	<u>INPUT RATING</u>
------------------	---------------------

0-4500 ft. (0-1400 m)	30,000 BTU/hr (8,800 watts)
-----------------------	-----------------------------

4500 ft. (1400 m) +	30,000 BTU/hr (8,800 watts) less 4% per 1000 ft. (300 m)
---------------------	--

Please contact your local utility or distributor for the appropriate orifice size you require.

*NOTE: THE INPUT RATING SHOULD ALWAYS BE CHECKED WHEN FIRST RUNNING THIS APPLIANCE. To do this, reduce the background flow rate, time the meter, light the fireplace and take another reading after fifteen minutes of operation. Check with your gas supplier for the gas BTU content at your elevation. Input is the rate of flow multiplied by the heating value of the gas (cubic feet/hour x BTU per cubic feet). Adjust the manifold pressure so that the unit does not operate above the rated input. To do this, loosen the screw on the variable input knob on the valve and reposition that the maximum input is correct. Retighten the screw. The manifold pressure is factory checked and should not require adjusting.*

## ELECTRICAL CONNECTIONS

**WARNING: Before starting make certain the power supply is turned off.**

The Optima 70 comes complete with a temperature activated fan and rheostat installed and wired to an internal junction box. The heat sensor is factory set to close the circuit to the fan speed control at 110 F and will turn off the fan when the temperature falls below 90 F.

Have a qualified electrician run a 120VAC supply line to the lower left side of the fireplace before installing the appliance. He should leave 18" (460mm) of the supply line free for ease of connection to the appliance. Connect the electrical supply line to the appliance at the same time the gas line is being connected to the appliance.

Flip open the bottom grill and undo the 2 screws holding the control panel. Run the line into the left side of the appliance through the hole in the rear of the junction box and hold with a standard 7/8" clamp. Connect the (black) supply conductor to the free black conductor from the speed controller with a marrette type wire connector. Connect the 'neutral' white supply conductor to the free white conductor from the fan with a marrette type wire connector. Connect the 'ground' (green or bare) conductor to the ground screw in the junction box. Replace the junction box cover and control panel and fasten with the 2 screws. A BX connector or other suitable approved wiring strain relief must be installed on the junction box.



**INSTALLATION INSTRUCTIONS Cont...**

**WIRING DIAGRAM**

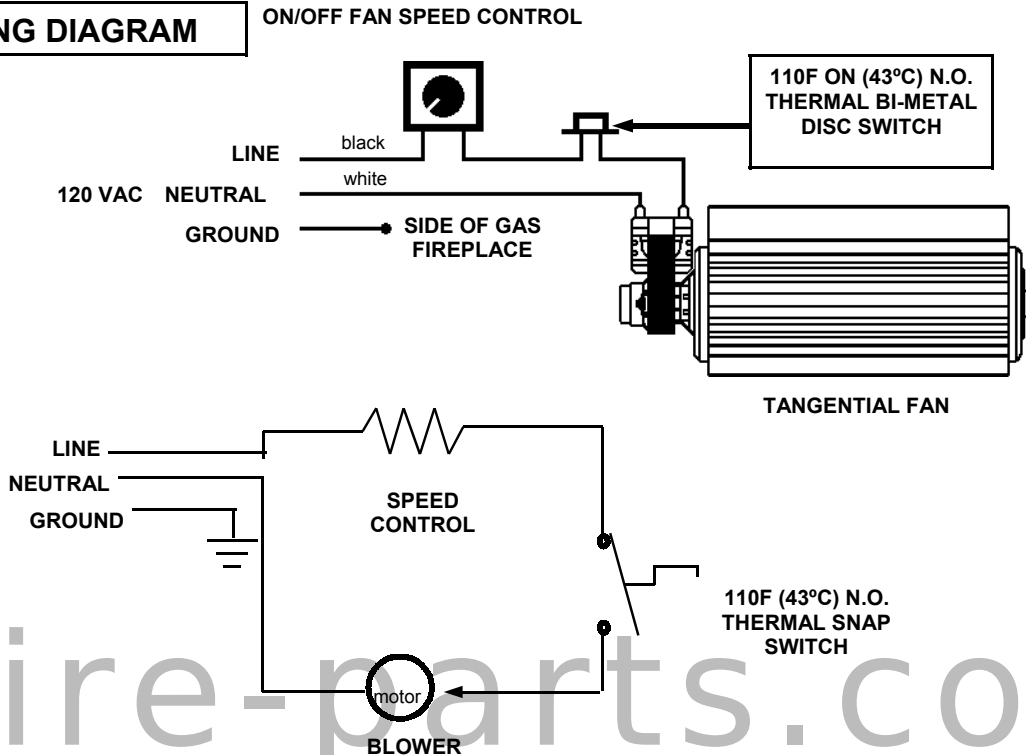

**VENT TERMINATION**

1. See ALLOWABLE TERMINATION LOCATIONS (page 12) and establish a suitable vent termination location.
2. In heavy snowfall areas make sure the vent termination is located where it can not be blocked by snow from snow removal equipment. A vent riser/snorkel kit is available if needed. ( P/N SNK-24 )
3. Locate the vent termination away from plants, bushes or any other object near the vent termination that will interfere or obstruct the air flow around it.
4. DO NOT recess the vent termination into walls, sidings or planters.
5. Vent terminations located below 7ft from grade level or anywhere that it can be a burn hazard to the public, such as patios and balconies, must be protected with an Archgard approved termination cage.

**ALLOWABLE TERMINATIONS LOCATIONS.**

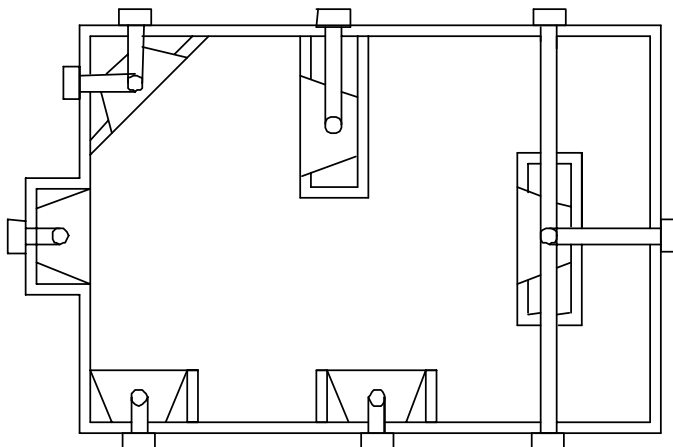

**PLEASE:**  
See venting chart on (page 12) for maximum and minimum vertical/horizontal venting configurations.

**INSTALLATION INSTRUCTIONS**

**FRAMING DIMENSIONS**

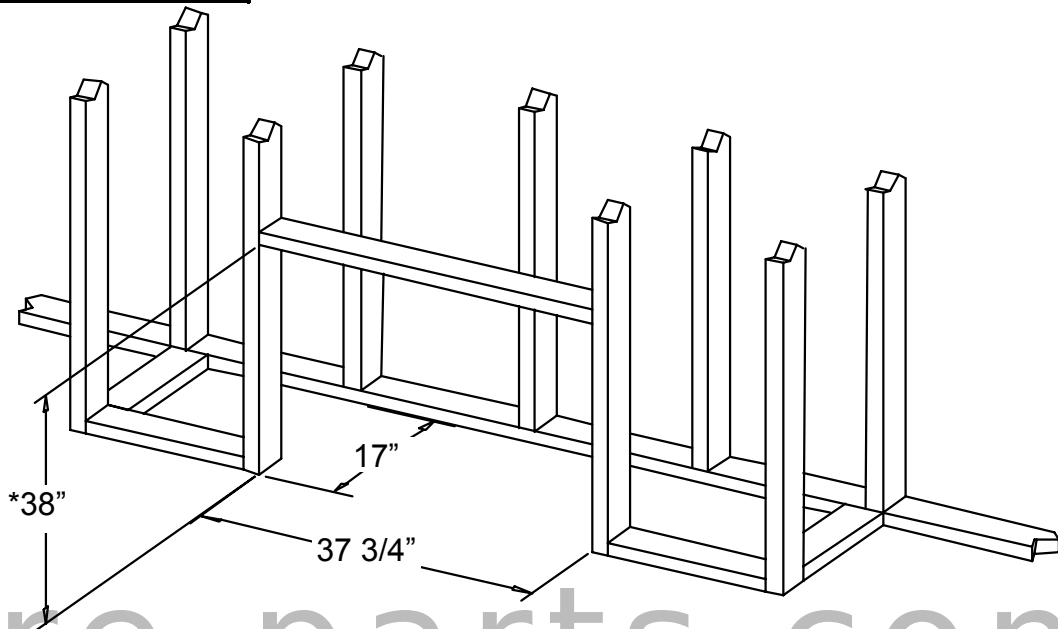

\* This dimension allows the top of the fireplace to slide under. If more rigidity is required, a stud may be added to the back of the fireplace top nailing flange after the fireplace is installed.

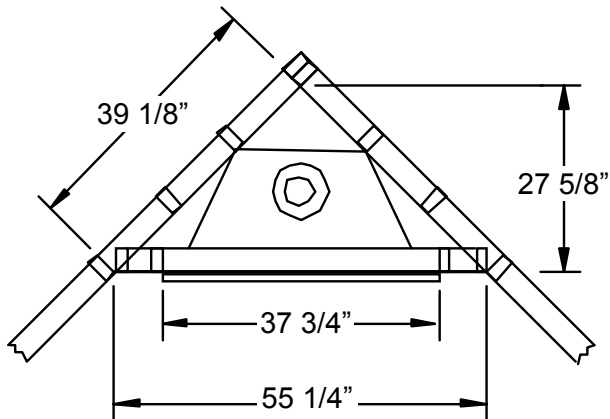
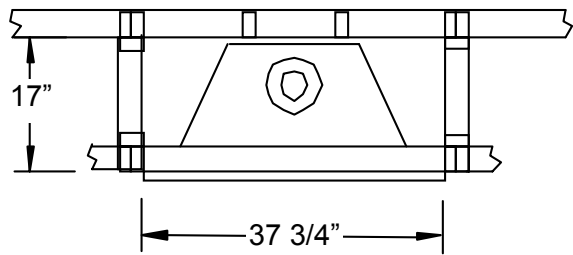

**TERMINATION FRAMING**

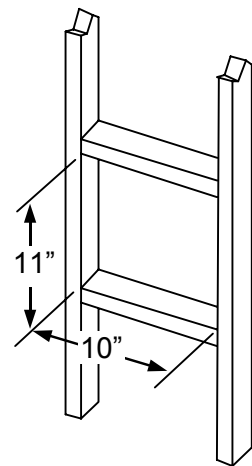

**NOTE:** Be sure to include 1/4" rise per foot of horizontal length.

**INSTALLATION INSTRUCTIONS Cont...**

**VENTING**

The appliance will not function without being connected to a proper venting system. This appliance may only use direct vent system supplied by Archgard, or Simpson Dura-Vent direct vent systems with Archgard SDK-1 adapter.

**VENTING CHART**

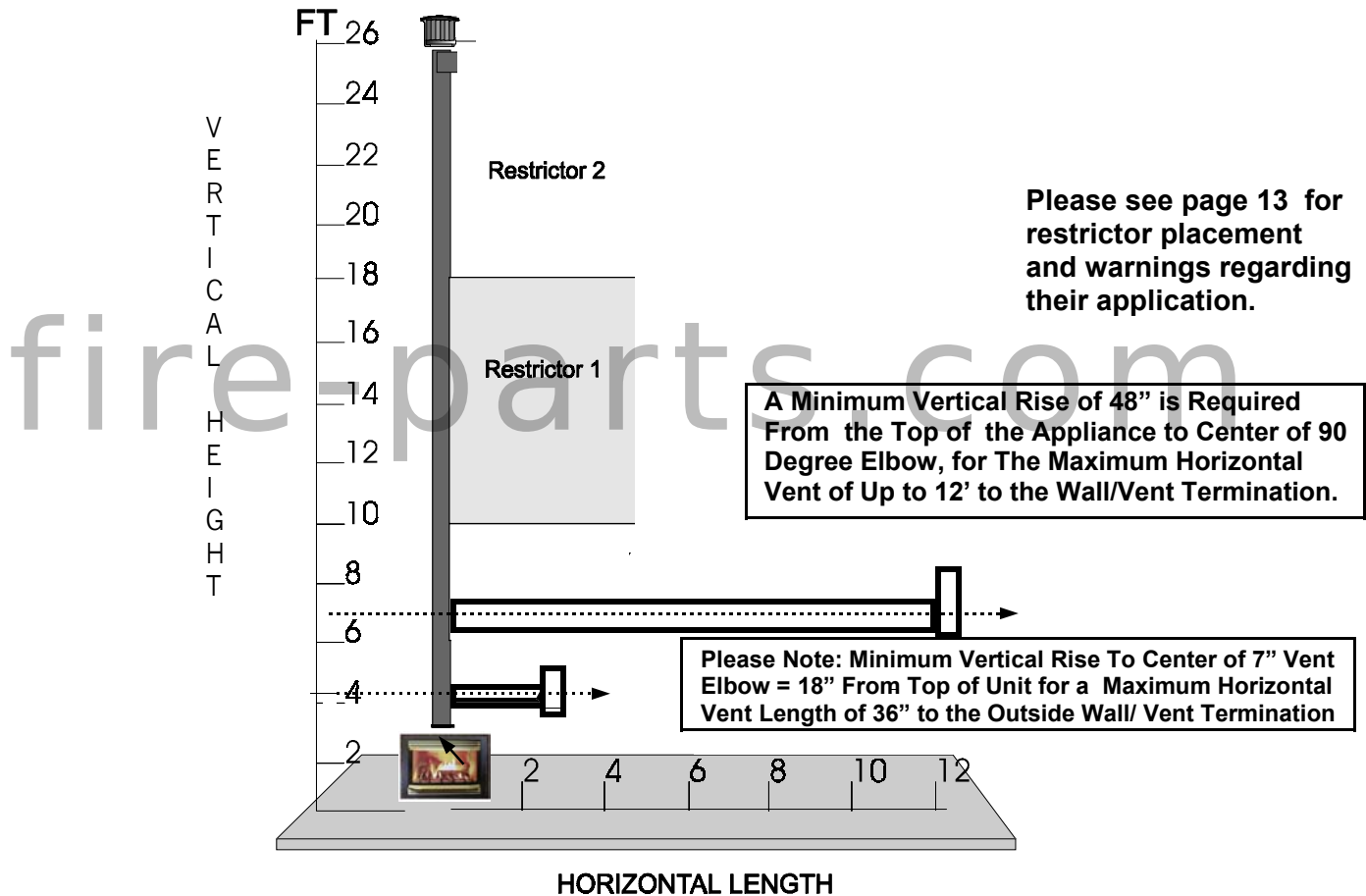

- Chart is for one 90° bend, **with a 1/4" (7 mm) minimum vertical rise per running foot** of horizontal length. For horizontal venting more than the 36" shown above, add 3.5" of vertical vent for each additional 12" of desired horizontal vent up to a maximum of 48" high by 120" horizontal.
- For each additional 90° or two 45°, add one foot of vertical height.
- Maximum three 90° bends, or equivalent.
- Minimum 2 ft (610 mm) straight length between bends.

**VENTING ABOVE ROOF OF THE HOUSE USING A VERTICAL TERMINATION**  
 Use Simpson Dura-Vent listed direct vent system caps for all vertical vent termination applications (through the roof).

**Please, strictly follow the venting instructions for Optimum performance from the appliance, and to avoid sooting and/or service calls.**

ALLOWED TERMINATION LOCATION

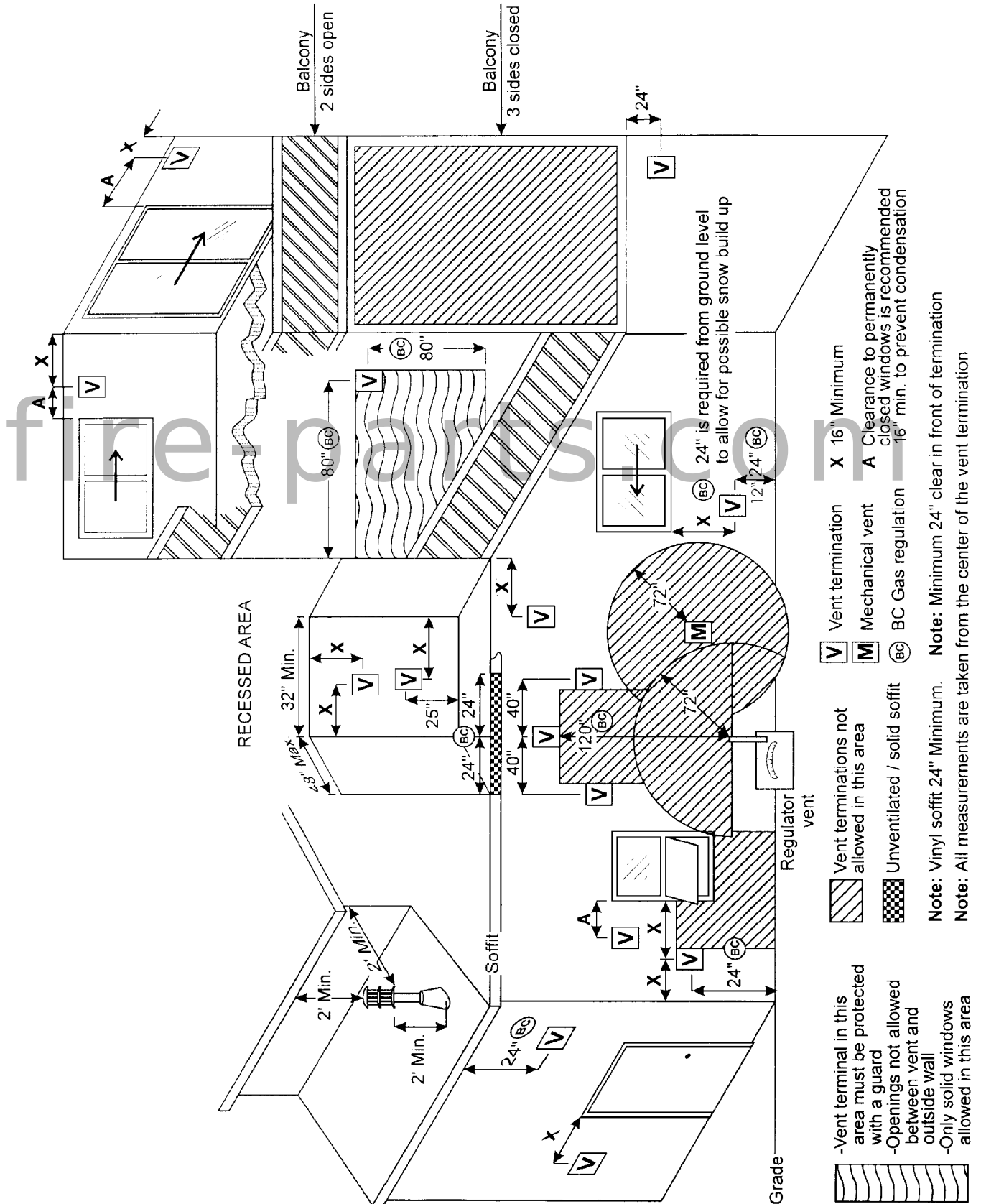

## INSTALLATION INSTRUCTIONS Cont...

### RESTRICTOR PLACEMENT “FOR ROOFTOP VENTED APPLICATIONS ONLY”

**WARNING:** These restrictors are only to be installed in the vent system if the vent exceeds 10' in vertical height, \*Restrictor Number 1 below is required and if the vent system exceeds 18' vertically, \*Restrictor Number 2 below is Required. Installing them **under any other circumstances may cause hazardous venting conditions and may result in personal injury, property damage or death.**  
“NOT FOR USE IN SIDEWALL VENTED APPLICATIONS”



**Rooftop Venting Above Ten Feet (10')**  
\* Restrictor Number 1



**Rooftop Venting Above Eighteen Feet (18')**  
\* Restrictor Number 2

**NOTE:** These vent restrictors are designed to reduce vertical stack action for rooftop vent terminations which will reduce the velocity of incoming combustion air and not adversely affect the standing pilot or the efficiency of the appliance.

#### Archgard System

In the Archgard system the restrictors are placed on the exhaust outlet on the appliance.

#### Simpson Duravent

With Simpson Duravent locate the restrictor in the exhaust section fitting into the formed lip.

**Simpson Duravent**



**Archgard System**



**Restrictor Placement**

**INSTALLATION INSTRUCTIONS Cont...**

**VENTING Cont...**

**For best and safe venting performance, here are some general venting rules:**

1. Use only Archgard or Simpson Dura Vent direct vent systems and components.
2. **Maintain a minimum of 1" (26 mm) clearance to combustibles from the outside surfaces of vertical vents and minimum of 1" (26 mm) sides and bottom, and 2" (51 mm) from top surfaces of horizontal vents.**
3. Observe any local code restrictions, if any, regarding the installation of this type of gas appliance.
4. **Observe the venting chart given in this manual. (Page 11)**
5. Use vent spacers between the inside 4" and outside 7" vents at every 3 ft (915 mm) intervals (Archgard vent kits only).
6. **Never slope horizontal vents downwards, towards the vent termination.**
7. **Maintain a minimum 1/4" rise (7 mm) for every linear foot (305 mm) of horizontal vent.**
8. Terminate the vent only with an approved vent termination supplied by Archgard Part # TK-1 or Simpson Dura Vent as listed below.
9. **Support horizontal vents every 3 ft (915 mm) to prevent sagging.**

**APPROVED VENT COMPONENTS**

PART #	DESCRIPTION
TVK-1	Flex Vent Kit with 36" vent length (includes TK1)
TVK-2	Flex Vent Kit with 60" vent length (includes TK1)
TK-1	Horizontal termination head only
VSD-1	Vinyl siding deflector
SNK-24	24" Snorkel
SDA-1	Unit to Simpson Dura-Vent adapter
SDA-3	Flex to Simpson Dura-Vent system adapter
DV-GS	Simpson Dura-Vent venting system

**VENTING CONNECTION**

The intake pipe shall be securely fastened to the appliance and to the terminal and all joints shall be secured using a minimum of 3 screws evenly spaced around the pipe.

Approximately 1" from the end of the 4" pipe outlet at the appliance and at the 4" terminal inlet apply a bead of Mil Pac 1/4" wide. Slide the 4" pipe onto the appliance and secure with 3 screws evenly spaced to the outlet. Repeat the procedure at the terminal inlet.

Install a vent spacer between the outer and the inner liner to maintain clearances. Spacers shall be installed at every change of direction. (Please see the diagram on page 15.)

Clearance to combustible material and fire-stops shall be installed as required by local codes and in the absence of local codes, in accordance with the local enforcing authority.

**INSTALLATION INSTRUCTIONS Cont...**

**VENT KIT COMPONENTS (TVK-1)**



Termination



Fire-stop



Sleeve



7" and 4" flex vent lengths (compressed)



Cement

Screws



Spring spacers

fire-parts.com

**VENT ASSEMBLY**

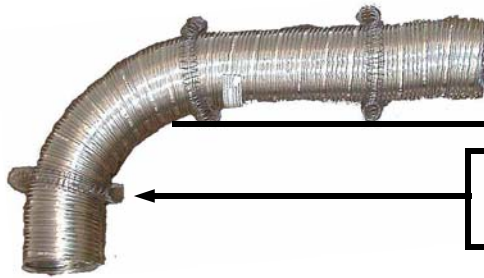

4" exhaust vent with spring spacers

**NOTE PITCH UP TOWARDS THE SIDEWALL VENT TERMINAL**

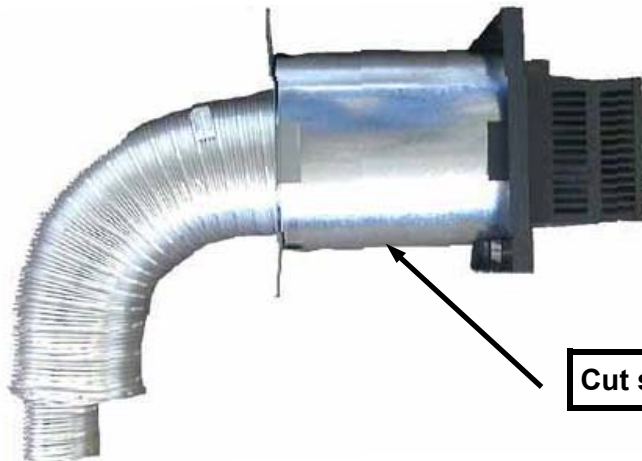

Vent system assembled With proper pitch to sidewall vent terminal

Cut sleeve to fit wall thickness

**INSTALLATION INSTRUCTIONS Cont...****GLASS DOOR**

**WARNING:** Do not attempt to remove the glass door when the appliance is hot.

**Removing the Glass Door**

Remove the top louver and open bottom louver

There are 2 buckle latches under the door frame. Lift the lever on the back of the latches to release them. Unhook the latches from the bottom of the door. Swing the bottom of the door towards you. Lift up on the whole door to unhook the top of door. Carefully remove the door put it away at a safe location where it cannot be scratched or damaged.

**Replacing the Glass Door**

The reverse procedure of Removing the Glass Door.

fire-parts.com

top of door  
hooks onto  
fireplace

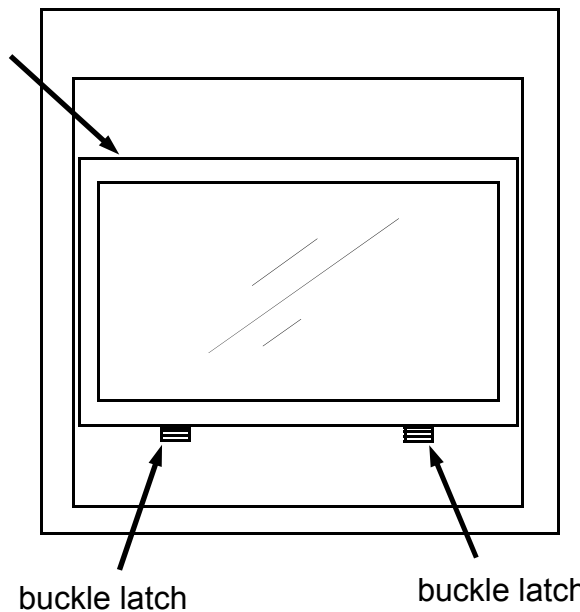



**INSTALLATION INSTRUCTIONS Cont...****PLACEMENT OF LOGS AND BRANCHES**

- Locate the rear log on the locator pins and then the front logs on their pins. The branch fits over top as shown.

**PLACEMENT OF EMBERS**

- A small bag of coals and embers are provided with the fireplace.
- Carefully place the coals and embers on the ledge between the grate and the front of the burner
- **DO NOT** allow the embers to obstruct the burner ports.
- **DO NOT** add more coals and embers than required or add foreign materials not supplied with this appliance, as dangerous operating conditions may occur.



**WARNING: Do not place logs in any other configuration than that shown. Under no circumstances are logs to be modified.**

**INSTALLATION INSTRUCTIONS Cont...****OPTIONAL BAY DOOR INSTALLATION**

**NOTE: THE OPTIONAL BAY DOOR IS A DECORATIVE OPTION ONLY AND IS MANUFACTURED WITH TEMPERED GLASS. THIS UNIT MUST NOT BE OPERATED WITHOUT THE FLAT CERAMIC GLASS DOOR SECURED IN PLACE, BEHIND IT.**

- 1 **NOTE:** Ensure that the fireplace is turned off and cool.
- 2 Remove the upper grilles by pulling the assembly forward.
- 3 Remove the lower grilles by removing the four hex head mounting screws.
- 4 Install The knob extensions on the valve.
- 5 Move the bay assembly over the front of the appliance, center in front of the flat door and hang over existing door.

fire-parts.com

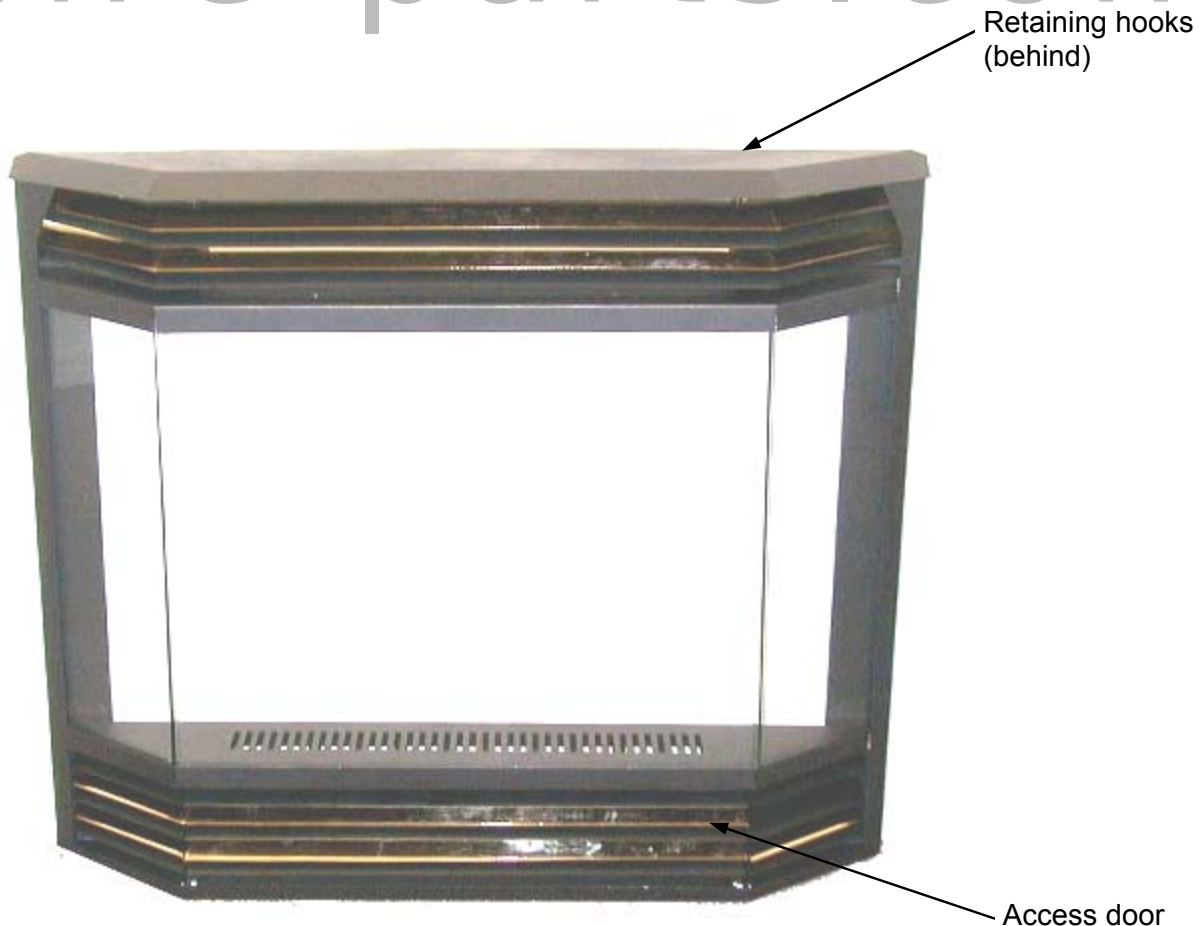

**OPERATION INSTRUCTIONS****FOR YOUR SAFETY, READ BEFORE LIGHTING****INITIAL OPERATION**

- Check that the appliance is properly vented and connected to the gas supply.
- Check that the logs and branches are properly placed.
- Check that all external parts, such as grills, door and faceplate are properly attached and fastened.
- Check that there are no finger prints left on gold surfaces as high temperature can bake these prints permanently.

**NOTE :** When operated for the first few times, the appliance will emit some odor and fumes. This is due to the heat from the appliance evaporating the oils and solvents used in fabricating the appliance. Close off the room to the rest of the house and open all windows. Keep the room well ventilated as smoke alarm may sound. Run the appliance for at least 4 hours at maximum setting with blower set to "OFF" to allow paint to cure.

**WARNING :** If you do not follow these instructions exactly, a fire or explosion may result, causing property damage, personal injury or loss of life. Do not operate the appliance with the glass front removed, cracked or broken. Replacement of the glass should be done by a licensed or qualified service person.

## OPERATION INSTRUCTIONS Cont..

### LIGHTING INSTRUCTIONS (copy of instruction plate found in control panel)

#### FOR YOUR SAFETY READ BEFORE LIGHTING

**WARNING: If you do not follow these instructions exactly, a fire of explosion may result causing property damage, personal injury or loss of life.**

- A. This appliance has a pilot which must be lighted by a spark ignitor. When lighting the pilot follow these instructions exactly.
- B. BEFORE LIGHTING smell all around the appliance area for gas. Be sure to smell next to the floor because some gas is heavier than air and will settle on the floor.
- WHAT TO DO IF YOU SMELL GAS
- Do not try to light any appliance.
  - Do not touch any electrical switch; do not use any phone in your building.
  - Immediately call your gas supplier from a neighbor's phone. Follow the gas supplier's instructions.
- C. Use only your hand to push in or turn the gas control knob. Never use tools. If the knob will not push in or turn by hand don't try to repair it, call a qualified service technician. Force or attempted repair may result in a fire or explosion.
- D. Do not use this appliance if any part has been under water. Immediately call a qualified service technician to inspect the appliance and to replace any part of the control system and any gas control which has been under water.
- If you cannot reach your gas supplier, call the fire department.

#### LIGHTING INSTRUCTIONS

1. STOP! Read the safety information above on this label.
2. Set the remote switch to "OFF". Set the thermostat to the lowest setting. (Only if your appliance is equipped with these devices.)
3. Turn off all electric power to the appliance.
4. Open lower louvers or access door.
3. Press slightly and turn the control knob clockwise  $\curvearrowright$  to the "OFF" position.
4. Wait 5 minutes to clear out any gas. Then smell for gas, including near the floor. If you smell gas, STOP! and follow instruction "B" above.
5. Find pilot. It is located between the logs near the center behind the burner.
6. Press slightly and turn control knob counterclockwise  $\curvearrowleft$  to "PILOT". Depress knob and light pilot by repeatedly pressing the sparker. Once flame is established, hold knob depressed for approximately 30 seconds. Release knob. If pilot should go out, repeat steps 3 to 5.
  - If the knob does not pop up when released, stop and immediately call your service technician or gas supplier.
  - If the pilot will not stay lit after several tries, turn the gas control knob to "OFF" and call your service technician or gas supplier.
7. If the appliance has a manual valve, turn gas control knob counterclockwise  $\curvearrowleft$  to the desired heat setting from If the appliance has an automatic valve, turn gas control knob counterclockwise  $\curvearrowleft$  to "ON" and set the flame adjustment knob to the desired heat setting from "LO" to "HI".
8. Set the remote switch to "ON". Set the thermostat to the desired setting. (Only if your appliance is equipped with these devices.)
9. Turn on all electric power to the appliance.
10. Close louver or access door.

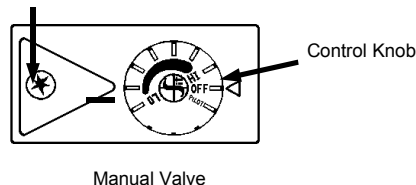
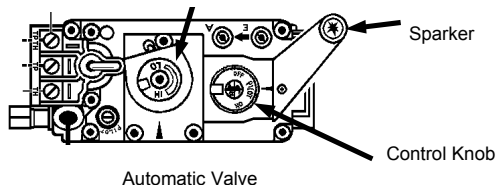

Pilot

#### TO TURN OFF GAS TO APPLIANCE

1. Set the thermostat to the lowest setting and turn the remote switch to "OFF".
2. Turn off all electric power to the appliance if service is to be performed.
3. Open lower louvers or access door.
4. Press slightly and turn control knob clockwise  $\curvearrowright$  to "OFF". Do not force.
5. Close lower louvers or access door.

## MAINTENANCE

**CAUTION** : Do not conduct maintenance on the appliance while it is operating or while it is still hot.

### CLEANING THE APPLIANCE

The exterior painted surfaces, glass and gold trims may be cleaned with a soft, non-abrasive cloth and water or a suitable, mild, non-abrasive cleaner.

#### Regularly:

- Clean and remove any lint accumulations or debris from the grills and in any combustion and convection air passage ways.
- Keep the appliance area free from combustible materials, such as paper, wood, clothing, gasoline and flammable solids, liquids and vapors.
- Visually check the height and color of the burner and pilot flames.

#### Every 2 to 3 months:

- Remove the glass door and clean the inside of the glass with a soft, non-abrasive cloth and water or a suitable, mild, non-abrasive cleaner. **DO NOT CLEAN WHILE HOT.**
- Carefully remove the logs and gently brush off any loose carbon deposits. This job is best done outside the house, wearing a dust mask. The logs are very fragile, take care not to break them. **Do not wash logs with any liquid.** While logs are removed, also remove the coals and “embers” and check that all burner openings are not obstructed. It is recommended you use a vacuum cleaner to clean off any dust or lint.
- After cleaning, the logs, coals and embers must be replaced as per the instructions in this manual.

#### Once a Year have a qualified service technician:

- Completely inspect the appliance and the venting system. Vent connection can be checked by removing the vent baffle in the firebox. Remove the 5 — 1/4 hex head screws holding the baffle. Replace baffle after inspection.
- Clean and remove any lint accumulations or debris in the firebox, on the burners, on the pilot, at the primary air opening, on the convection air blower and in any combustion and convection air passage ways.
- Check the safety system of the gas valve and the appliance.

**WARNING** : All parts removed or disturbed including guards and grills must be properly replaced after maintenance. Service and repair must be conducted by a qualified service person. If these instructions are not followed, a fire or explosion may result, causing property damage, personal injury or loss of life

## TROUBLE SHOOTING

Please check to make sure the instructions are followed exactly before attempting trouble shooting of the appliance.

**WARNING:** Trouble shooting and servicing of gas and electrical devices of the appliance should only be conducted by a qualified service technician.

SYMPTOM	ACTION
Pilot will not light after pressing the sparker many times.	<ol style="list-style-type: none"> <li>1. When lighting the appliance for the first time after installation or after servicing, there is air in the gas line. It takes a while for all the air to purge out of the pilot before gas can reach the pilot and ignite. Remove the glass door and try lighting the pilot many times to purge the air.</li> <li>2. Check to make sure the gas supply to the appliance is turned on and there is adequate gas supply pressure to the appliance.</li> <li>3. Check for sparks between the spark electrode and the pilot head when the sparker is pressed. If there are no sparks,               <ol style="list-style-type: none"> <li>a. Check for broken or poor connection from the sparker to the electrode.</li> <li>b. Check for the spark shorting or arcing at other locations.</li> <li>c. Check for defective sparker.</li> <li>d. Check for defective spark electrode.</li> </ol> </li> <li>4. With the door removed, try lighting the pilot with a match.               <ol style="list-style-type: none"> <li>a. If air is blowing on the flame of the match, hold the control knob in at the '<b>PILOT</b>' setting until all the air is purged out of the line.</li> <li>b. If there is no gas or air coming out of the pilot and there is gas pressure to the appliance, the pilot orifice may be blocked or the gas valve may be defective.</li> </ol> </li> </ol>
Pilot will not remain on after being lit.	<ol style="list-style-type: none"> <li>1. Press the control knob all the way in.</li> <li>2. Hold the control knob in for a longer period of time.</li> <li>3. If you are trying to re-light the pilot immediately after you have shut-off the pilot, you have to wait 5 minutes for the valve to reset.</li> <li>4. Check to see if the pilot flame is large enough to reach and surround the thermocouple. If the flame is too small, check for correct gas supply pressure. If pressure is good, adjust the pilot flame size with the adjustment screw on the valve. If the flame cannot be adjusted, there might be some debris obstructing the pilot orifice, or a wrong size pilot orifice.</li> <li>5. Check for poor connection of the thermocouple to the valve.</li> <li>6. Check for proper millivolts of the thermocouple. The thermocouple should generate at least 30 mV or it is defective.</li> <li>7. Check for defective gas valve.</li> </ol>
The main burner does not turn on with the pilot lit.	<ol style="list-style-type: none"> <li>1. Check to make sure the control knob is turned to the '<b>ON</b>' position.</li> <li>2. Allow enough time for the pilot to heat up the thermopile to generate sufficient voltage to activate the valve.</li> </ol>

### TROUBLE SHOOTING Cont...

SYMPTOM	ACTION
The main burner does not turn on with the pilot lit. Cont...	<ol style="list-style-type: none"> <li>3. Check to make sure the thermostat is set high enough to turn on the appliance.</li> <li>4. Check that the remote switch or the thermostat is turned on.</li> <li>5. Check for weak pilot flame. If flame is weak, check gas supply, check pilot flame adjustment and check for blockage of pilot orifice.</li> <li>6. Check all connections to the valve for tight electrical contact.</li> <li>7. Check spill switch for continuity.</li> <li>8. Check for 400-500 mV from the thermopile with the burner off and 200-250 mV with the burner on. If the voltages are lower, the thermopile is defective.</li> <li>9. Check for defective gas valve.</li> </ol>
The main burner shuts off when the appliance is warm.	<ol style="list-style-type: none"> <li>1. This may be the normal operation of a wall thermostat installed to appliances.</li> <li>2. Check for good pilot flames on the thermopile (see page 22).</li> <li>3. Check for good voltage from the thermopile.</li> <li>4. Check for proper functioning of venting system.</li> <li>5. Check wire connections. Expansion from heat affects a loose connection</li> </ol>
Sooty deposits on the glass door.	<ol style="list-style-type: none"> <li>1. If the flame is yellow and lazy, check for lint etc. around primary air shutter. Increase primary air by opening the primary air shutter if necessary.</li> <li>2. Check for proper placement of the logs and branches. Ensure logs and burner are clean. See that section in the instruction manual.</li> <li>3. Check for obstruction of the burner ports by the embers. See that section in the instruction manual.</li> <li>4. Check for proper venting and blockage of the vent termination.</li> <li>5. Check manifold pressure and clock input rating for over-firing.</li> </ol>
Sharp blue flames with flames lifting off the burner at the ends.	<ol style="list-style-type: none"> <li>1. Too much primary air. Reduce primary air by closing the primary air shutter. During cold temperatures, some flame lifting may occur during start-up.</li> </ol>
Convection blower does not turn on.	<ol style="list-style-type: none"> <li>1. The convection fan is thermostatically controlled. It will only turn on when the appliance is warmed-up. This may take up to 15 minutes with the appliance on high.</li> <li>2. Check for 120 VAC electrical supply to the appliance. (Is the cord plugged in?)</li> <li>3. Check for proper mounting of the thermal snap disc.</li> <li>4. Check electrical connections.</li> <li>5. Check for defective thermal snap disc.</li> <li>6. Check for defective convection blower speed controller.</li> <li>7. Check for defective convection blower.</li> </ol>

**WIRING DIAGRAMS**

**VALVE CONNECTIONS**

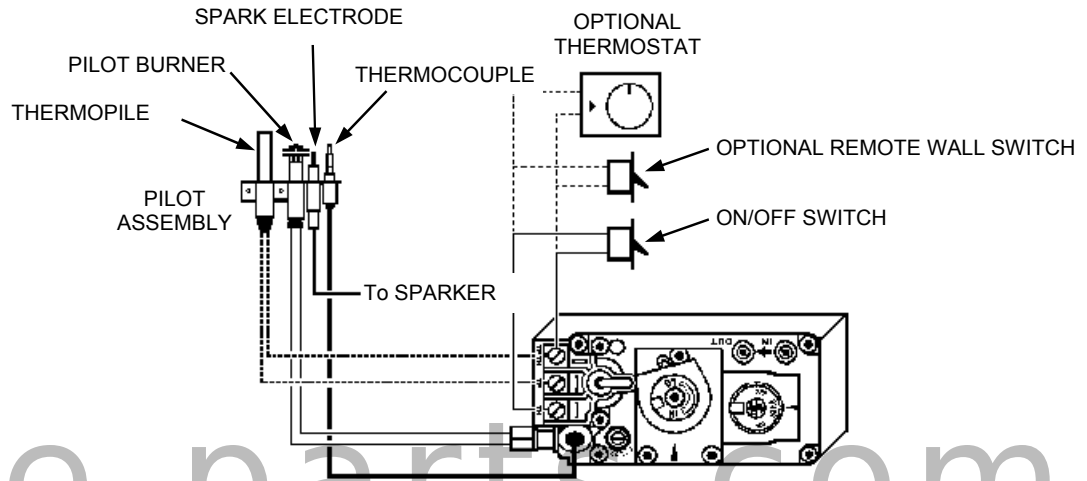

fire-parts.com



## SERVICING

### SERVICING UNDER WARRANTY

Before servicing, read the terms and conditions of the Archgard warranty at the back of the manual. Contact the Archgard authorized dealer which you have purchased the appliance from and provide him with details of the problem and the installation information which the installer has fill out at the back of the manual.

**WARNING:** Servicing of this appliance **must be conducted by a qualified service technician.** Improper servicing, adjustment or alteration of this appliance may cause property damage, personal injury or loss of life. All servicing should be conducted with the appliance cold. All replacement parts must be authorized by Archgard for suitability.

### ADJUSTING PRIMARY AIR

Note: the Shutter is set at the factory and normally only requires setting at higher altitudes.

- Open the lower grilles.
- Unscrew the 2 screws holding the blower speed control panel and remove the panel.
- The primary air adjustment wing nut is located behind and to the left of the control valve.
- Loosen the wing nut and slide the primary air shutter to the right to increase primary air and to left to reduce primary air. **WARNING: Any Adjustment to Primary Air Should Only Be Attempted by a Qualified, Licensed Gas Fitter or Service Person.**
- Tighten the wing nut after adjustment.

**Caution:** Wear gloves when adjusting the primary air with the appliance hot.

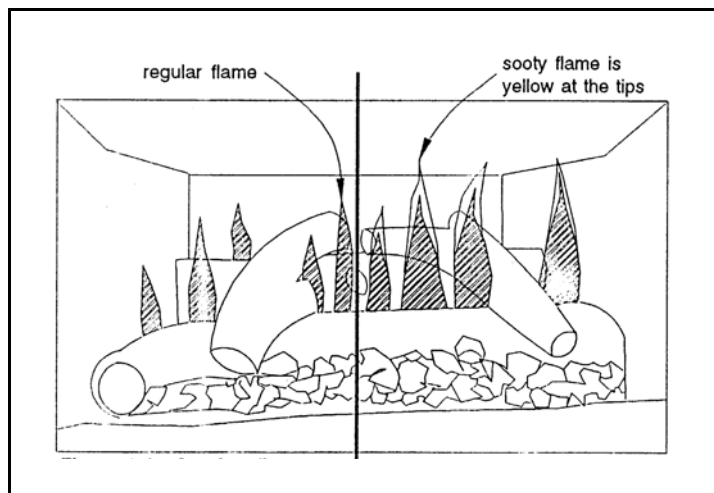
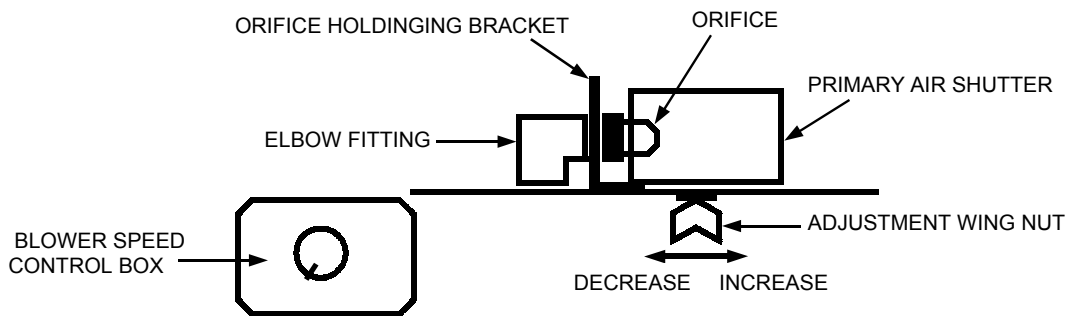

### FLAMES...

The left side shows correct adjustment. The right side shows yellow sooty flames requiring increase in shutter opening or cleaning of shutter area due to lint buildup.

## SERVICING Cont...

### CHANGING MAIN BURNER ORIFICE

- Remove the glass door, log branch and the front logs.
- Unscrew the 2 screws holding the left burner shields between the burner tubes and remove the shield.
- Remove the adjustment wing nut from the underside the firebox and slide the air shutter away from the orifice cap.
- Use a 1/2" wrench to remove the orifice cap.
- Change the orifice cap. Use a small quantity of gas thread seal compound. Do not over tighten.
- Replace the adjustment wing nut and properly set the primary air shutter according to the specifications on page 4
- Replace the burner shield, front logs, branch and the glass door.

### CHECKING INLET AND OUTLET GAS PRESSURE

- Open the lower grills.
- The pressure test taps are located on the valve.

**Automatic valve:** The taps are located in the front. The inlet is marked 'IN' and the outlet is marked 'OUT'. There is also an arrow marking the direction of gas flow.

**Manual valve:** The taps are located on the left side of the valve. The connection closest to the back, marked with 'IN' is the inlet and the outlet marked with 'OUT' is closest to the front.

- Loosen the set screw inside the tap with a 1/8" wide flat screw driver.
- Connect a 1/4" rubber tube to the tap and to the manometer.
- Be sure to tighten the set screw inside the tap after you are finish taking pressure readings.
- Check for leaks.

### CHECKING AND ADJUSTING PILOT

The pilot flame should have the characteristic as shown in the illustration below. The flame should not have yellow tips but should engulf the thermocouple and thermopile. It can be adjusted by turning the screw marked "pilot" on the control valve.

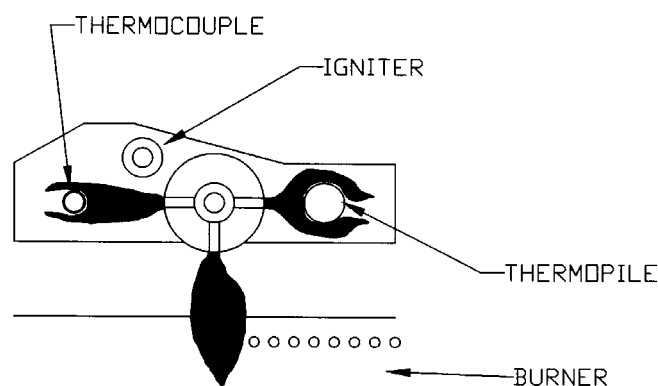

## SERVICING Cont...

### REPLACING PILOT ORIFICE

Pilot  
burner

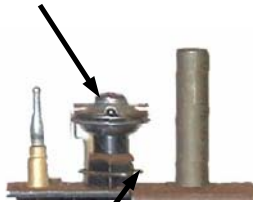

Retaining  
clip

The pilot orifice sits underneath the pilot burner head. Remove the head just by pulling it off. You may have to wiggle it a bit. **DO NOT REMOVE THE RETAINING CLIP.** Use a 5/32 Allen wrench to remove the orifice. Replace in reverse order. There is a notch in the head to line it up correctly on replacement. Ensure the head is pushed down all the way.

fire-parts.com

### IF YOUR GLASS BREAKS

In the event your glass cracks or breaks, it must be replaced by the exact same size and material. It is made from high temperature ceramic material. See replacement parts list and contact your nearest Archgard dealer.

- Remove door and carefully remove all traces of glass and gasket material.
- Replacement requires Ceramic glass part #307-0019, gasket part #314-0000 and sealer part #319-0005.
- Install new glass with new gasketing in place. The “thicker” side of the gasket fits against the fireplace opening.
- Hold glass in place by using the sealer between gasket and door. Use sparingly so that no excess will be visible. **DO NOT PUT ANY SEALER BETWEEN GLASS AND UNIT OPENING.**
- Replace the door carefully making sure all two clamps are closed.

### REPLACING CONVECTION BLOWER

- Remove the gas component assembly, see above.
- Mark all wires to be removed for proper reassembly. **CAUTION:** Wiring errors cause improper and dangerous operation.
- The convection blower is located at the bottom of the appliance at the back. Remove the three screws holding the blower.
- Lift the blower out and disconnect the wires from the blower.



**Replacement Parts for OPTIMA 70**

Item #	Item Description	Qty	Unit
200-0051	OWNER'S MANUAL, OPTIMA 70	1	EA
300-0031	MAGNET, .1/4" x .875" X 1", #7 PULL	2	EA
300-0034	CATCH, DOOR LATCH, 1-11/16" x 1-3/16"	2	EA
301-0023	ORIFICE, CAP #53	1	EA
301-0038	ORIFICE, CAP #37	1	EA
305-0013	SPEED CONTROL, C/W PALE NUT & KNOB, 120V	1	EA
305-0015	ELECTRIC FAN, CROSSFLOW 115 V FAN LH	1	EA
305-0021	THERMODISC 110 DEG FAN SWITCH	1	EA
307-0019	GLASS CERAMIC 17.25 X 30.5 (OI70/ER65)	1	EA
307-0030	GLASS, 6MMTEMP 19.188X22.312 POL. 2 SHRT	1	EA
307-0031	GLASS, 6MM TEMP 6.75x19.187 POL. 1 LONG	2	EA
308-0007	PIEZO IGNITOR FOR MOUNTING ON VALVE SIT	1	EA
308-0012	VALVE, SIT NOVA MV HI-LO (LP)	1	ea
308-0013	VALVE, SIT NOVA MV HI-LO (NG)	1	EA
308-0048	KNOB EXT. ON/OFF 2.5"	1	EA
308-0049	KNOB EXT. HI/LO 2.5"	1	EA
308-0054	PILOT ASSEMBLY, CONVERTIBLE PILOT LP SIT	1	EA
308-0055	PILOT ASSEMBLY, CONVERTIBLE PILOT NG SIT	1	EA
310-0009	COALS, MEDIUM GRADE 4OZ BAG	1	EA
310-0032	LOG, REAR OPTIMA 35/70	1	EA
310-0033	LOG, CROSS OPTIMA 35/70	1	EA
310-0046	MINERAL WOOL, "EMBERS"	1	OZ
310-0070	Log, Front Left, Optima 35/70	1	EA
310-0071	Log, Front Right, Optima 35/70	1	EA
311-0017	BRICK LINER EURO 65/70 RH (713-0032)	1	EA
311-0018	BRICK LINER EURO 65/70 LH (713-0032)	1	EA
311-0019	BRICK LINER, OPT 70 REAR	1	EA
312-0015	CONNECTOR, GAS 3/8 MIP x 3/8 FIP x 24"	1	EA
314-0000	GASKET GF - TADPOLE 1.38"	100	IN
314-0006	GASKET - 1/8" X 1" WHITE KNITTED FG	72	IN
314-0101	GASKET, RELIEF PLATE 3.5 X 15 (736-0040)	1	EA
317-0024	BURNER - OPT35/70 (703-0043)	1	EA
713-0013	CHANNEL TOP	1	EA
713-0015	CHANNEL BOTTOM	1	EA
719-0010	LOG REST	2	EA
719-0011	REAR LOG REST	1	EA

**Parts can be ordered through your local dealer or distributor by giving ITEM # and DESCRIPTION.**



## ARCHGARD LIMITED WARRANTY

This Limited Warranty is made by ARCHGARD INDUSTRIES LTD. hereinafter referred to as "Archgard". Archgard warrants to the original consumer that the gas burning fireplaces will be free from defects in materials and workmanship under normal use and service, for a lifetime.

### INCLUSIONS:

- Combustion chamber, burner pans & burner tubes, log sets (including embers) and all gold plating.
- Electrical components and gas valves are covered under the warranty for a period of 1 year from purchase.

### EXCLUSIONS:

- Paint, glass, trim, gasket, brick panels, parts which have been tampered with or modified in any way.
- Negligence, misuse, accidental damage.
- Special environmental conditions, which may cause spillage or downdraft conditions due to negative room air pressure, geographical location, inadequate ventilation or excessive offsets.

### WHAT TO DO IN THE EVENT OF A PROBLEM:

- Thoroughly read your manual.
- If you cannot solve the problem yourself contact your Archgard dealer or representative.
- When calling for help have the following information available:

<b>Model Name</b>	<b>Serial Number</b>	
<b>Date of Purchase</b>	<b>Place of Purchase</b>	<b>Problem Description</b>

**NOTE:** Warranty may be void if work is carried out by unqualified personnel. Only original Archgard parts may be used. Please consult your Archgard representative if in doubt.

### OBTAINING WARRANTY SERVICE:

To obtain warranty service, the consumer shall return the defective part to the original selling dealer transportation prepaid, along with the serial number of the appliance and proof of purchase. Any defective part, in our judgment, will be repaired or replaced at Archgard's discretion. The dealer must obtain approval from an authorized Archgard representative before any repairs are made.

### WARRANTY LIMITATION:

THIS LIMITED WARRANTY IS MADE IN LIEU OF ALL OTHER WARRANTIES, EXPRESSED OR IMPLIED AS TO QUALITY, MERCHANTABILITY OR FITNESS FOR PARTICULAR PURPOSE.

The appliance is only warranted for the use as intended by the installation and operating instructions and local building codes. The warranty will not cover damage due to accident, misuse, abuse, alteration or improper installation.

This limited warranty is void unless the appliance is installed by a qualified installer, in accordance with the instructions furnished with the appliance. Some Provinces or States do not allow limitations on how long an implied warranty lasts, so the above limitation may not apply to the consumer.

Any damages resulting from defects in this product, is limited to replacement of defective parts and does not include incidental and consequential expenses sustained in connection with the product. This warranty is limited to residential use only and gives the consumer specific rights. These rights may vary from State to State or Province to Province.

Postage

**WARRANTY REGISTRATION**

**ARCHGARD INDUSTRIES LTD.  
7116 BEATTY DRIVE  
MISSION, B.C. CANADA  
V2V 6B4**

FOLD DOWN AT LINE

fire-parts.com

FOLD DOWN AT LINE & TAPE CLOSED

Model No: \_\_\_\_\_ Date Installed: \_\_\_\_/\_\_\_\_/\_\_\_\_

Serial No: \_\_\_\_\_

Name & Address: \_\_\_\_\_

Telephone: ( \_\_\_\_\_ ) \_\_\_\_\_ - \_\_\_\_\_

Dealer's Name & Address: \_\_\_\_\_  
\_\_\_\_\_

Installer's Name & Address: \_\_\_\_\_  
\_\_\_\_\_

Why did you choose this product? \_\_\_\_\_  
\_\_\_\_\_

*Thank you for purchasing our product and filling out this warranty card.*