

Models:
6000CBV-IPI
8000CBV-IPI

See Toolbox/Website
for most current
Service Parts
Information

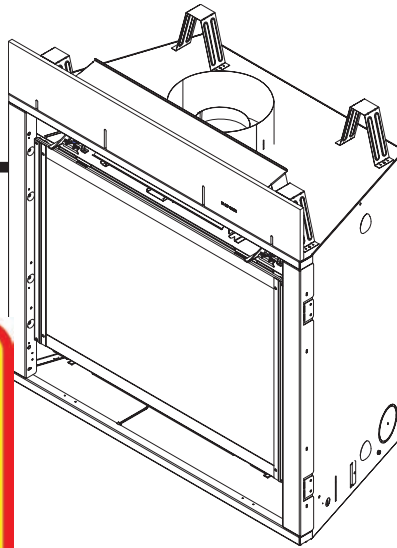

NOTICE



DO NOT DISCARD THIS MANUAL

- Important operating and maintenance instructions included.
- Read, understand and follow these instructions for safe installation and operation.
- Leave this manual with party responsible for use and operation.



⚠ WARNING: If the information in these instructions is not followed exactly, a fire or explosion may result causing property damage, personal injury, or death.

- **DO NOT** store or use gasoline or other flammable vapors and liquids in the vicinity of this or any other appliance.
- **What to do if you smell gas**
 - **DO NOT** try to light any appliance.
 - **DO NOT** touch any electrical switch. **DO NOT** use any phone in your building.
 - Immediately call your gas supplier from a neighbor's phone. Follow the gas supplier's instructions.
 - If you cannot reach your gas supplier, call the fire department.
- Installation and service must be performed by a qualified installer, service agency, or the gas supplier.

⚠ WARNING



HOT SURFACES!

Glass and other surfaces are hot during operation AND cool down.

Hot glass will cause burns.

- **DO NOT** touch glass until it is cooled
 - **NEVER** allow children to touch glass
 - Keep children away
 - **CAREFULLY SUPERVISE** children in same room as fireplace.
 - Alert children and adults to hazards of high temperatures.
- High temperatures may ignite clothing or other flammable materials.**
- Keep clothing, furniture, draperies and other flammable materials away.

This appliance has been supplied with an integral barrier to prevent direct contact with the fixed glass panel. DO NOT operate the appliance with the barrier removed.

Contact your dealer or Hearth & Home Technologies if the barrier is not present or help is needed to properly install one.

In the Commonwealth of Massachusetts installation must be performed by a licensed plumber or gas fitter.
A CO detector shall be installed in the room where the appliance is installed.



Installation and service of this appliance should be performed by qualified personnel. Hearth & Home Technologies suggests NFI certified or factory trained professionals, or technicians supervised by an NFI certified professional.

Read this manual before installing or operating this appliance.
Please retain this owner's manual for future reference.

A. Congratulations

Congratulations on selecting a Heat & Glo gas fireplace, an elegant and clean alternative to wood burning fireplaces. The Heat & Glo gas fireplace you have selected is designed to provide the utmost in safety, reliability, and efficiency.

As the owner of a new fireplace, you'll want to read and carefully follow all of the instructions contained in this owner's manual. Pay special attention to all cautions and warnings.

This owner's manual should be retained for future reference. We suggest that you keep it with your other important documents and product manuals.

The information contained in this owner's manual, unless noted otherwise, applies to all models and gas control systems.

Your new Heat & Glo gas fireplace will give you years of durable use and trouble-free enjoyment. Welcome to the Heat & Glo family of fireplace products!

| | |
|--|---|
| Homeowner Reference Information | <i>We recommend that you record the following pertinent information about your fireplace.</i> |
| Model Name: _____ | Date purchased/installed: _____ |
| Serial Number: _____ | Location on fireplace: _____ |
| Dealership purchased from: _____ | Dealer Phone: _____ |
| Notes: _____ | _____ |

fire-parts.com

Listing Label Information/Location

The model information regarding your specific fireplace can be found on the rating plate usually located in the control area of the fireplace.

This product may be covered by one or more of the following patents: (Nos produits sont couverts par un ou plusieurs des brevets suivants): (United States) 4593510, 4686807, 4766876, 4793322, 4811534, 5000162, 5016609, 5076254, 5113843, 5191877, 5218953, 5263471, 5328356, 5341794, 5347983, 5428495, 5452708, 5542407, 5601073, 5613487, 5647340, 5688568, 5762062, 5775408, 5890485, 5931661, 5941237, 5947112, 5996575, 6006743, 6019099, 6048195, 6053165, 6145502, 6170481, 6237588, 6296474, 6374822, 6413079, 6439228, 6484712, 6543698, 6550687, 6601579, 6672860, 6688302B2, 6715724B2, 6729551, 6736133, 6748940, 6748942, D320652, D445174, D462436; (Canada) 1297749, 2195264, 2225406; or other U.S. and foreign patents pending (ou autres brevets americains et etrangers en attente).

HEAT & GLO
No one builds a better fire

Heat & Glo, a brand of Hearth & Home Technologies, Inc.
20802 Kensington Boulevard, Lakeville, MN 55044

Not for use with solid fuel.
(Ne doit pas être utilisé avec un combustible solide).

Type of Gas (Sorte De Gaz): **NATURAL GAS**

This appliance must be installed in accordance with local codes, if any; if not, follow ANSI Z223.1 in the USA or CAN/CGA B149 Installation codes. *(Installer l'appareil selon les codes ou règlements locaux ou, en l'absence de tels règlements, selon les codes d'installation CAN/CGA-B149.)*

ANSI Z21XX-XXXX · CSA 2.0X-MXX · UL307B

Minimum Permissible Gas Supply for Purposes of Input Adjustment.

| | | |
|--------------------------------------|-------------|------------------|
| Approved Minimum (De Gaz) Acceptable | 0.0 in w.c. | (Po. Col. d'eau) |
| Maximum Pressure (Pression) | 0.0 in w.c. | (Po. Col. d'eau) |
| Maximum Manifold Pressure (Pression) | 0.0 in w.c. | (Po. Col. d'eau) |
| Minimum Manifold Pressure (Pression) | 0.0 in w.c. | (Po. Col. d'eau) |

Total Electrical Requirements: 000Vac, 00Hz., less than 00 Amperes

GAS-FIRED



MADE IN USA

| | | | | |
|------------------|------------|--------------|------------------|----------|
| ALTITUDE: | 0-0000 FT. | 0000-0000FT. | Model: | XXXXXXXX |
| MAX. INPUT BTUH: | 00,000 | 00,000 | (Modele): | _____ |
| MIN. INPUT BTUH: | 00,000 | 00,000 | Serial | XXXXXXXX |
| ORIFICE SIZE: | #XXXXX | #XXXXX | (Serie): | _____ |

Type of Gas →

Gas and Electric Information →

Model Number →

Serial Number →

▲ Safety Alert Key:

- **DANGER!** Indicates a hazardous situation which, if not avoided will result in death or serious injury.
- **WARNING!** Indicates a hazardous situation which, if not avoided could result in death or serious injury.
- **CAUTION!** Indicates a hazardous situation which, if not avoided, could result in minor or moderate injury.
- **NOTICE:** Used to address practices not related to personal injury.

Table of Contents

| | |
|--|---|
| A. Congratulations | 2 |
| B. Limited Lifetime Warranty | 5 |

1 Listing and Code Approvals

| | |
|--|---|
| A. Appliance Certification | 7 |
| B. Glass Specifications | 7 |
| C. BTU Specifications | 7 |
| D. High Altitude Installations | 7 |
| E. Non-Combustible Materials Specification | 7 |
| F. Combustible Materials Specification | 7 |
| G. Electrical Codes | 7 |

User Guide

2 Operating Instructions

| | |
|---|----|
| A. Gas Fireplace Safety | 8 |
| B. Your Fireplace | 8 |
| C. Fan Kit (optional) | 9 |
| D. Clear Space | 9 |
| E. Decorative Doors and Fronts | 9 |
| F. Fixed Glass Assembly | 9 |
| G. Remote Controls, Wall Controls and Wall Switches | 9 |
| H. Outside Air (optional) | 9 |
| I. Before Lighting Fireplace | 9 |
| J. Lighting Instructions (IPI) | 10 |
| K. After Fireplace is Lit | 11 |
| L. Frequently Asked Questions | 11 |

3 Maintenance and Service

| | |
|---|----|
| A. Maintenance Tasks-Homeowner | 12 |
| B. Maintenance Tasks-Qualified Service Technician | 13 |
| C. Refractory, Grate and Valve Assembly Removal | 14 |
| D. Burner Identification/Verification | 15 |

Installer Guide

4 Getting Started

| | |
|---|----|
| A. Typical Appliance System | 16 |
| B. Design and Installation Considerations | 17 |
| C. Tools and Supplies Needed | 17 |
| D. Inspect Appliance and Components | 17 |
| E. Negative Pressure | 18 |

5 Framing and Clearances

| | |
|---|----|
| A. Selecting Appliance Location | 19 |
| B. Constructing the Appliance Chase | 20 |
| C. Clearances | 20 |
| D. Mantel and Wall Projections | 21 |

6 Termination Locations

| | |
|--|----|
| A. Vent Termination Minimum Clearances | 22 |
|--|----|

7 Vent Information and Diagrams

| | |
|--|----|
| A. Vent Guidelines | 23 |
| B. Vent System Configuration | 23 |

8 Vent Clearances and Framing

| | |
|---|----|
| A. Pipe Clearances to Combustibles | 24 |
| B. Wall and Ceiling Penetration Framing | 24 |
| C. Vertical Penetration Framing | 24 |

9 Appliance Preparation

| | |
|---|----|
| A. Installing Outside Air Kit Damper Assembly | 25 |
| B. Gas and Electrical Connections | 25 |
| C. Installing the Non-combustible Board | 25 |
| D. Securing and Leveling the Appliance | 26 |

10 Installing Vent Pipe

| | |
|--|----|
| A. Assembly of Vent Sections | 27 |
| B. Attaching Vent to Firebox | 27 |
| C. Securing Vent Sections | 27 |
| D. Install Attic Insulation Shield | 27 |

11 Gas Information

| | |
|--|----|
| A. Fuel Conversion | 28 |
| B. Gas Pressure | 28 |
| C. Gas Connection | 28 |
| D. High Altitude Installations | 28 |

12 Electrical Information

| | |
|--|----|
| A. Wiring Requirements | 29 |
| B. IntelliFire Plus™ Ignition System Wiring | 29 |
| C. Optional Accessories Requirements | 29 |
| D. Electrical Service and Repair | 30 |
| E. Junction Box Installation | 30 |
| F. Wall Switch Installation for Fan (Optional) | 31 |
| G. Control Module Operation | 31 |

13 Finishing

| | |
|--|----|
| A. Mantel and Wall Projections | 32 |
| B. Facing Material | 32 |
| C. Doors | 33 |

14 Appliance Setup

| | |
|--|----|
| A. Remove Glass Assembly | 36 |
| B. Remove the Shipping Materials | 36 |
| C. Clean the Appliance | 36 |
| D. Accessories | 36 |
| E. Burner Top Installation | 36 |
| F. Ember Placement. | 36 |
| G. Install the Log Assembly. | 37 |
| H. Fixed Glass Assembly | 41 |
| I. Install Trim and/or Surround. | 41 |
| J. Air Shutter Setting | 41 |

15 Troubleshooting

| | |
|--|----|
| A. IntelliFire Plus™ Ignition System | 42 |
|--|----|

16 Reference Materials

| | |
|---|----|
| A. Appliance Dimension Diagram. | 44 |
| → B. Service Parts | 46 |
| C. Contact Information | 50 |

fire-parts.com

→ = Contains updated information.

B. Limited Lifetime Warranty

Hearth & Home Technologies Inc. LIMITED LIFETIME WARRANTY

Hearth & Home Technologies Inc., on behalf of its hearth brands ("HHT"), extends the following warranty for HHT gas, wood, pellet, coal and electric hearth appliances that are purchased from an HHT authorized dealer.

WARRANTY COVERAGE:

HHT warrants to the original owner of the HHT appliance at the site of installation, and to any transferee taking ownership of the appliance at the site of installation within two years following the date of original purchase, that the HHT appliance will be free from defects in materials and workmanship at the time of manufacture. After installation, if covered components manufactured by HHT are found to be defective in materials or workmanship during the applicable warranty period, HHT will, at its option, repair or replace the covered components. HHT, at its own discretion, may fully discharge all of its obligations under such warranties by replacing the product itself or refunding the verified purchase price of the product itself. The maximum amount recoverable under this warranty is limited to the purchase price of the product. This warranty is subject to conditions, exclusions and limitations as described below.

WARRANTY PERIOD:

Warranty coverage begins on the date of installation. In the case of new home construction, warranty coverage begins on the date of first occupancy of the dwelling or six months after the sale of the product by an independent, authorized HHT dealer/ distributor, whichever occurs earlier. The warranty shall commence no later than 24 months following the date of product shipment from HHT, regardless of the installation or occupancy date. The warranty period for parts and labor for covered components is produced in the following table.

The term "Limited Lifetime" in the table below is defined as: 20 years from the beginning date of warranty coverage for gas appliances, and 10 years from the beginning date of warranty coverage for wood, pellet, and coal appliances. These time periods reflect the minimum expected useful lives of the designated components under normal operating conditions.

| Warranty Period | | HHT Manufactured Appliances and Venting | | | | | | | Components Covered |
|------------------|---------|---|------|--------|----------|------|----------|---------|--|
| Parts | Labor | Gas | Wood | Pellet | EPA Wood | Coal | Electric | Venting | |
| 1 Year | | X | X | X | X | X | X | X | All parts and material except as covered by Conditions, Exclusions, and Limitations listed |
| 2 years | | | | X | X | X | | | Igniters, electronic components, and glass |
| | | X | X | X | X | X | | | Factory-installed blowers |
| | | | | X | | | | | Molded refractory panels |
| 3 years | | | | X | | | | | Firepots and burnpots |
| 5 years | 1 year | | | X | X | | | | Castings and baffles |
| 7 years | 3 years | | X | X | X | | | | Manifold tubes, HHT chimney and termination |
| 10 years | 1 year | X | | | | | | | Burners, logs and refractory |
| Limited Lifetime | 3 years | X | X | X | X | X | | | Firebox and heat exchanger |
| 90 Days | | X | X | X | X | X | X | X | All replacement parts beyond warranty period |

See conditions, exclusions, and limitations on next page.

WARRANTY CONDITIONS:

- This warranty only covers HHT appliances that are purchased through an HHT authorized dealer or distributor. A list of HHT authorized dealers is available on the HHT branded websites.
- This warranty is only valid while the HHT appliance remains at the site of original installation.
- Contact your installing dealer for warranty service. If the installing dealer is unable to provide necessary parts, contact the nearest HHT authorized dealer or supplier. Additional service fees may apply if you are seeking warranty service from a dealer other than the dealer from whom you originally purchased the product.
- Check with your dealer in advance for any costs to you when arranging a warranty call. Travel and shipping charges for parts are not covered by this warranty.

WARRANTY EXCLUSIONS:

This warranty does not cover the following:

- Changes in surface finishes as a result of normal use. As a heating appliance, some changes in color of interior and exterior surface finishes may occur. This is not a flaw and is not covered under warranty.
- Damage to printed, plated, or enameled surfaces caused by fingerprints, accidents, misuse, scratches, melted items, or other external sources and residues left on the plated surfaces from the use of abrasive cleaners or polishes.
- Repair or replacement of parts that are subject to normal wear and tear during the warranty period. These parts include: paint, wood, pellet and coal gaskets; firebricks; grates; flame guides; and the discoloration of glass.
- Minor expansion, contraction, or movement of certain parts causing noise. These conditions are normal and complaints related to this noise are not covered by this warranty.
- Damages resulting from: (1) failure to install, operate, or maintain the appliance in accordance with the installation instructions, operating instructions, and listing agent identification label furnished with the appliance; (2) failure to install the appliance in accordance with local building codes; (3) shipping or improper handling; (4) improper operation, abuse, misuse, continued operation with damaged, corroded or failed components, accident, or improperly/incorrectly performed repairs; (5) environmental conditions, inadequate ventilation, negative pressure, or drafting caused by tightly sealed constructions, insufficient make-up air supply, or handling devices such as exhaust fans or forced air furnaces or other such causes; (6) use of fuels other than those specified in the operating instructions; (7) installation or use of components not supplied with the appliance or any other components not expressly authorized and approved by HHT; (8) modification of the appliance not expressly authorized and approved by HHT in writing; and/or (9) interruptions or fluctuations of electrical power supply to the appliance.
- Non-HHT venting components, hearth components or other accessories used in conjunction with the appliance.
- Any part of a pre-existing fireplace system in which an insert or a decorative gas appliance is installed.
- HHT's obligation under this warranty does not extend to the appliance's capability to heat the desired space. Information is provided to assist the consumer and the dealer in selecting the proper appliance for the application. Consideration must be given to appliance location and configuration, environmental conditions, insulation and air tightness of the structure.

This warranty is void if:

- The appliance has been over-fired or operated in atmospheres contaminated by chlorine, fluorine, or other damaging chemicals. Over-firing can be identified by, but not limited to, warped plates or tubes, rust colored cast iron, bubbling, cracking and discoloration of steel or enamel finishes.
- The appliance is subjected to prolonged periods of dampness or condensation.
- There is any damage to the appliance or other components due to water or weather damage which is the result of, but not limited to, improper chimney or venting installation.

LIMITATIONS OF LIABILITY:

- The owner's exclusive remedy and HHT's sole obligation under this warranty, under any other warranty, express or implied, or in contract, tort or otherwise, shall be limited to replacement, repair, or refund, as specified above. In no event will HHT be liable for any incidental or consequential damages caused by defects in the appliance. Some states do not allow exclusions or limitation of incidental or consequential damages, so these limitations may not apply to you. This warranty gives you specific rights; you may also have other rights, which vary from state to state. EXCEPT TO THE EXTENT PROVIDED BY LAW, HHT MAKES NO EXPRESS WARRANTIES OTHER THAN THE WARRANTY SPECIFIED HEREIN. THE DURATION OF ANY IMPLIED WARRANTY IS LIMITED TO DURATION OF THE EXPRESSED WARRANTY SPECIFIED ABOVE.

1 Listing and Code Approvals

A. Appliance Certification

MODELS: 6000CBV-IPI, 8000CBV-IPI
LABORATORY: Underwriters Laboratories, Inc. (UL)
TYPE: B-Vent Gas Appliance
STANDARD: ANSI Z21.50a-2008 • CSA 2.22a-2008

This product is listed to ANSI standards for “Vented Gas Fireplaces” and “Gas Fired Appliances for Use at High Altitudes”.

May be installed in a sleeping room when the provisions for combustion, ventilation and dilution air are met per the requirements of **ANSI Z23.1/NFPA 54 National Fuel Gas Code**. In Canada, installation in a sleeping room requires installation with a thermostat certified for use with this product. Consult your local authorities having jurisdiction.

NOTICE: This installation must conform with local codes. In the absence of local codes you must comply with the National Fuel Gas Code, ANSI Z223.1-latest edition in the U.S.A. and the CAN/CGA B149 Installation Codes in Canada.

NOT INTENDED FOR USE AS A PRIMARY HEAT SOURCE.
This appliance is tested and approved as either supplemental room heat or as a decorative appliance. It should not be factored as primary heat in residential heating calculations.

B. Glass Specifications

Hearth & Home Technologies appliances manufactured with tempered glass may be installed in hazardous locations such as bathtub enclosures as defined by the Consumer Product Safety Commission (CPSC). The tempered glass has been tested and certified to the requirements of **ANSI Z97.1** and **CPSC 16 CFR 1202** (Safety Glazing Certification Council **SGCC# 1595** and **1597**. Architectural Testing, Inc. Reports **02-31919.01** and **02-31917.01**).

This statement is in compliance with **CPSC 16 CFR Section 1201.5** “Certification and labeling requirements” which refers to **15 U.S. Code (USC) 2063** stating “...Such certificate shall accompany the product or shall otherwise be furnished to any distributor or retailer to whom the product is delivered.”

Some local building codes require the use of tempered glass with permanent marking in such locations. Glass meeting this requirement is available from the factory. Please contact your dealer or distributor to order.

C. BTU Specifications

| Models <small>U.S. (0-2000 ft.) or Canada (2000-4500 ft.)</small> | | Maximum Input BTUH | Minimum Input BTUH | Orifice Size (DMS) |
|--|-----|--------------------|--------------------|--------------------|
| 6000CBV-IPI | US | 29,000 | 20,000 | 39 |
| | CAN | 26,100 | 18,000 | 40 |
| 6000CBV-IPI (LP) | US | 27,000 | 21,000 | 52 |
| | CAN | 24,300 | 18,900 | 53 |
| 8000CBV-IPI | US | 35,000 | 25,000 | 34 |
| | CAN | 31,500 | 22,500 | 35 |
| 8000CBV-IPI (LP) | US | 32,500 | 24,000 | 51 |
| | CAN | 29,250 | 21,600 | 52 |

D. High Altitude Installations

NOTICE: If the heating value of the gas has been reduced, these rules do not apply. Check with your local gas utility or authorities having jurisdiction.

When installing above 2000 feet elevation:

- In the USA: Reduce input rate 4% for each 1000 feet above 2000 feet.
- In CANADA: Reduce input rate 10% for elevations between 2000 feet and 4500 feet. Above 4500 feet, consult local gas utility.

Check with your local gas utility to determine proper orifice size.

E. Non-Combustible Materials Specification

Material which will not ignite and burn. Such materials are those consisting entirely of steel, iron, brick, tile, concrete, slate, glass or plasters, or any combination thereof.

Materials that are reported as passing **ASTM E 136, Standard Test Method for Behavior of Materials in a Vertical Tube Furnace at 750 °C** and **UL763** shall be considered non-combustible materials.

F. Combustible Materials Specification

Materials made of or surfaced with wood, compressed paper, plant fibers, plastics, or other material that can ignite and burn, whether flame proofed or not, or plastered or unplastered shall be considered combustible materials.

G. Electrical Codes

NOTICE: This appliance must be electrically wired and grounded in accordance with local codes or, in the absence of local codes, with **National Electric Code ANSI/NFPA 70-latest edition** or the **Canadian Electric Code CSA C22.1**.

- A 110-120 VAC circuit for this product must be protected with ground-fault circuit-interrupter protection, in compliance with the applicable electrical codes, when it is installed in locations such as in bathrooms or near sinks.

A. Gas Fireplace Safety

⚠ WARNING



HOT SURFACES!

Glass and other surfaces are hot during operation AND cool down.

Hot glass will cause burns.

- **DO NOT** touch glass until it is cooled
- **NEVER** allow children to touch glass
- Keep children away

- **CAREFULLY SUPERVISE** children in same room as fireplace.
- Alert children and adults to hazards of high temperatures.

High temperatures may ignite clothing or other flammable materials.

- Keep clothing, furniture, draperies and other flammable materials away.

This appliance has been supplied with an integral barrier to prevent direct contact with the fixed glass panel. DO NOT operate the appliance with the barrier removed.

Contact your dealer or Hearth & Home Technologies if the barrier is not present or help is needed to properly install one.

If you expect that small children or vulnerable adults may come into contact with this fireplace, the following precautions are recommended:

- Install a physical barrier such as:
 - A decorative firescreen.
 - Adjustable safety gate.
- Install a switch lock or a wall/remote control with child protection lockout feature.

- Keep remote controls out of reach of children.
- Never leave children alone near a hot fireplace, whether operating or cooling down.
- Teach children to **NEVER** touch the fireplace.
- Consider not using the fireplace when children will be present.

Contact your dealer for more information, or visit: www.hpba.org/staysafe.

To prevent unintended operation when not using your fireplace for an extended period of time (summer months, vacation, trips, etc):

- Remove batteries from remote controls.
- Turn off wall controls.
- Unplug 6 volt transformer plug and remove batteries on IPI models.

B. Your Fireplace

WARNING! DO NOT operate fireplace before reading and understanding operating instructions. Failure to operate fireplace according to operating instructions could cause fire or injury.

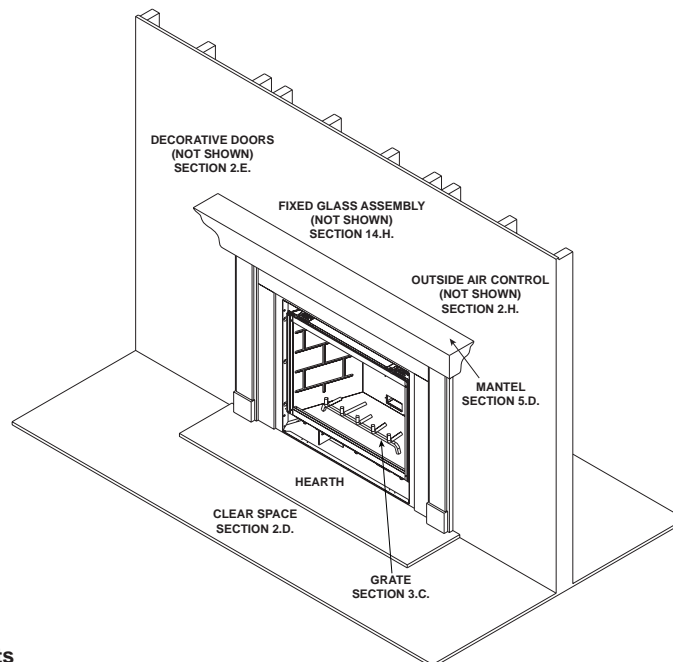

Figure 2.1 General Operating Parts

C. Fan Kit (optional)

If desired, a fan kit may be added. Contact your dealer to order the correct fan kit.

D. Clear Space

WARNING! DO NOT place combustible objects in front of the fireplace or block louvers. High temperatures may start a fire. See Figure 2.2.

Avoid placing candles and other heat-sensitive objects on mantel or hearth. Heat may damage these objects.

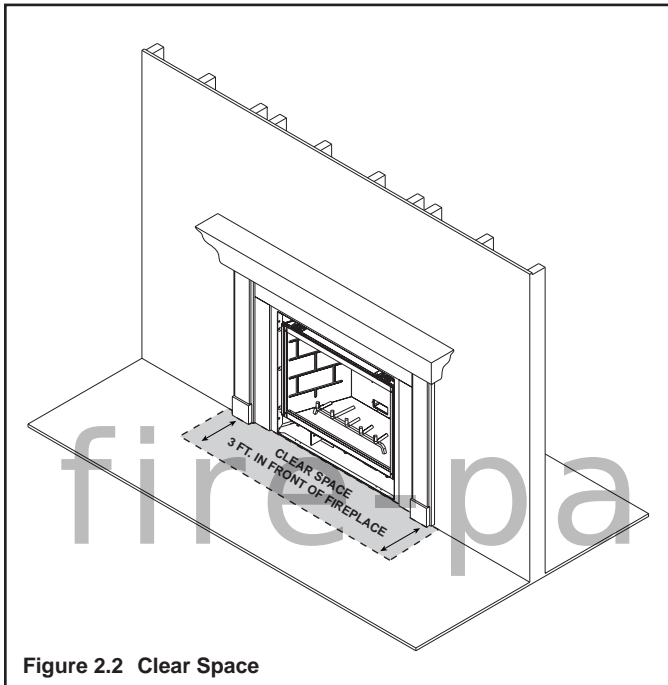

E. Decorative Doors and Fronts

WARNING! Risk of Fire! Install **ONLY** doors or fronts approved by Hearth & Home Technologies. Unapproved doors or fronts may cause fireplace to overheat.

This fireplace has been supplied with an integral barrier to prevent direct contact with the fixed glass panel. DO NOT operate the fireplace with the barrier removed.

Contact your dealer or Hearth & Home Technologies if the barrier is not present or help is needed to properly install one.

For more information refer to the instructions supplied with your decorative door or front.

F. Fixed Glass Assembly

See Section 14.H.

G. Remote Controls, Wall Controls and Wall Switches

Follow the instructions supplied with the control installed to operate your fireplace:

For safety:

- Install a switch lock or a wall/remote control with child protection lockout feature.
- Keep remote controls out of reach of children.

See your dealer if you have questions.

H. Outside Air (optional)

The outside air kit supplies some fresh combustion air for your fireplace. It may help reduce the effects of negative air pressure. (See Section 9.A.)

- Refer to Figure 9.2 for location of control.
- Close the inlet to prevent cold drafts when the fireplace is not being used.

CAUTION! Risk of Burns! The outside air control handle is **HOT** when fireplace is in operation. Adjust **BEFORE** lighting fire.

I. Before Lighting Fireplace

Before operating this fireplace for the first time, **have a qualified service technician:**

- Verify all shipping materials have been removed from inside and/or underneath the firebox.
- Review proper placement of logs, ember material and/or other decorative materials.
- Check the wiring.
- Check the air shutter adjustment.
- Ensure that there are no gas leaks.
- Ensure that the glass is sealed and in the proper position and that the integral barrier is in place.

WARNING! Risk of Fire/Asphyxiation! DO NOT operate fireplace with fixed glass assembly removed.

J. Lighting Instructions (IPI)

FOR YOUR SAFETY READ BEFORE LIGHTING

WARNING: If you do not follow these instructions exactly, a fire or explosion may result causing property damage, personal injury or loss of life.

- A.** This appliance is equipped with an intermittent pilot ignition (IPI) device which automatically lights the burner. **DO NOT** try to light the burner by hand.
- B. BEFORE LIGHTING**, smell all around the appliance area for gas. Be sure to smell next to the floor because some gas is heavier than air and will settle on the floor.
- WHAT TO DO IF YOU SMELL GAS**
- **DO NOT** try to light any appliance.
 - **DO NOT** touch any electric switch; do not use any phone in your building.
- C.** **DO NOT** use this appliance if any part has been under water. Immediately call a qualified service technician to inspect the appliance and to replace any part of the control system and any gas control which has been under water.
- Immediately call your gas supplier from a neighbor's phone. Follow the gas supplier's instructions.
 - If you cannot reach your gas supplier, call the fire department.

WARNING:

DO NOT CONNECT 110 VAC TO THE CONTROL VALVE.

Improper installation, adjustment, alteration, service or maintenance can cause injury or property damage. Refer to the owner's information manual provided with this appliance.

This appliance needs fresh air for safe operation and must be installed so there are provisions for adequate combustion and ventilation air.

If not installed, operated, and maintained in accordance with the manufacturer's instructions, this product could expose you to substances in fuel or fuel combustion which are known to the State of California to cause cancer, birth defects, or other reproductive harm.

Keep burner and control compartment clean. See installation and operating instructions accompanying appliance.

For additional information on operating your
Hearth & Home Technologies fireplace, please refer to www.fireplaces.com.

CAUTION:

Hot while in operation. **DO NOT** touch. Keep children, clothing, furniture, gas-line and other liquids having flammable vapors away.

DO NOT operate the appliance with fixed glass assembly removed, cracked or broken. Replacement of the fixed glass assembly should be done by a licensed or qualified service person.

NOT FOR USE WITH SOLID FUEL

For use with natural gas and propane. A conversion kit, as supplied by the manufacturer, shall be used to convert this appliance to the alternate fuel.

Also Certified for Installation in a Bedroom or a Bedsitting Room.

For assistance or additional information, consult a qualified installer, service agency or the gas supplier.

LIGHTING INSTRUCTIONS (IPI)

1. Turn off all electric power to the appliance.
2. This appliance is equipped with an ignition device which automatically lights the burner. **DO NOT** try to light the burner by hand.

**GAS
VALVE**

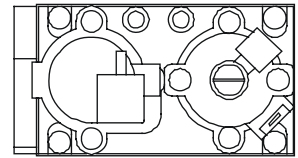

3. Wait five (5) minutes to clear out any gas. Then smell for gas, including near the floor. If you smell gas, **STOP!** Follow "B" in the Safety Information located on the left side of this label. If you do not smell gas, go to next step.
4. Turn on all electric power to the appliance.
5. To light the burner, flip the ON/OFF switch to the "ON" position. (The ON/OFF switch may include a wall switch if so equipped).
6. If the appliance will not operate, follow the instructions "To Turn Off Gas to Appliance" and call your service technician or gas supplier.

TO TURN OFF GAS TO APPLIANCE

1. Turn wall control or ON/OFF switch to "OFF".
2. Turn off all electric power to the appliance if service is to be performed.

593-913F

Final inspection by _____

K. After Fireplace is Lit

Initial Break-in Procedure

- The fireplace should be run three to four hours continuously on high.
- Turn the fireplace off and allow it to completely cool.
- Remove fixed glass assembly. See Section 14.H.
- Clean fixed glass assembly. See Section 3.
- Replace the fixed glass assembly and run continuously on high an additional 12 hours.

This cures the materials used to manufacture the fireplace.

NOTICE! Open windows for air circulation during fireplace break-in.

- *Some people may be sensitive to smoke and odors.*
- *Smoke detectors may activate.*

L. Frequently Asked Questions

| ISSUE | SOLUTIONS |
|---|---|
| Condensation on the glass | This is a result of gas combustion and temperature variations. As the appliance warms, this condensation will disappear. |
| Blue flames | This is a result of normal operation and the flames will begin to yellow as the appliance is allowed to burn for 20 to 40 minutes. |
| Odor from appliance | When first operated, this appliance may release an odor for the first several hours. This is caused by the curing of the paint and the burning off of any oils remaining from manufacturing. Odor may also be released from finishing materials and adhesives used around the appliance. |
| Film on the glass | This is a normal result of the curing process of the paint and logs. Glass should be cleaned within 3 to 4 hours of initial burning to remove deposits left by oils from the manufacturing process. A non-abrasive cleaner such as gas fireplace glass cleaner may be necessary. See your dealer. |
| Metallic noise | Noise is caused by metal expanding and contracting as it heats up and cools down, similar to the sound produced by a furnace or heating duct. This noise does not affect the operation or longevity of the appliance. |
| Is it normal to see the pilot flame burn continually? | In an intermittent pilot ignition system (IPI), the pilot flame should turn off when appliance is turned off. Some optional control systems available with IPI models may allow pilot flame to remain lit. |

3 Maintenance and Service

Any safety screen or guard removed for servicing must be replaced prior to operating the fireplace.

When properly maintained, your fireplace will give you many years of trouble-free service. We recommend annual service by a qualified service technician.

A. Maintenance Tasks-Homeowner

Installation and repair should be done by a qualified service technician only. The fireplace should be inspected before use and at least annually by a professional service person.

The following tasks may be performed annually by the homeowner. If you are uncomfortable performing any of the listed tasks, please call your dealer for a service appointment.

More frequent cleaning may be required due to lint from carpeting or other factors. Control compartment, burner and circulating air passageway of the fireplace must be kept clean.

CAUTION! Risk of Burns! The fireplace should be turned off and cooled before servicing.

Glass Cleaning

Frequency: Seasonally

By: Homeowner

Tools Needed: Protective gloves, glass cleaner, drop cloth and a stable work surface.

CAUTION! Handle fixed glass assembly with care. Glass is breakable.

- Avoid striking, scratching or slamming glass
 - Avoid abrasive cleaners
 - **DO NOT** clean glass while it is hot
 - Prepare a work area large enough to accommodate fixed glass assembly and door frame by placing a drop cloth on a flat, stable surface.
- Note:** Fixed glass assembly and gasketing may have residue that can stain carpeting or floor surfaces.
- Remove door or decorative front from fireplace and set aside on work surface.
 - See Section 14.H for instructions to remove fixed glass assembly.
 - Clean glass with a non-abrasive commercially available cleaner.
 - Light deposits: Use a soft cloth with soap and water
 - Heavy deposits: Use commercial fireplace glass cleaner (consult with your dealer)
 - Carefully set fixed glass assembly in place on fireplace. Hold glass in place with one hand and secure glass latches with the other hand.
 - Reinstall door or decorative front.

Doors, Surrounds, Fronts

Frequency: Annually

By: Homeowner

Tools needed: Protective gloves, stable work surface

- Assess condition of screen and replace as necessary.
- Inspect for scratches, dents or other damage and repair as necessary.
- Check that louvers are not blocked.
- Vacuum and dust surfaces.

Remote Control

Frequency: Seasonally

By: Homeowner

Tools needed: Replacement batteries and remote control instructions.

- Locate remote control transmitter and receiver.
- Verify operation of remote. Refer to remote control operation instructions for proper calibration and setup procedure.
- Place batteries as needed in remote transmitters and battery-powered receivers.
- Place remote control out of reach of children.

If not using your fireplace for an extended period of time (summer months, vacations/trips, etc), to prevent unintended operation:

- Remove batteries from remote controls.
- Unplug 6 volt transformer plug on IPI models.
- Remove battery backup from control module.

Venting

Frequency: Seasonally

By: Homeowner

Tools needed: Protective gloves and safety glasses.

- Inspect venting and termination cap for blockage or obstruction such plants, bird nests, leaves, snow, debris, etc.
- Verify termination cap clearance to subsequent construction. See Section 6.
- Inspect for corrosion or separation.
- Verify weather stripping, sealing and flashing remains intact.
- Inspect draft shield to verify it is not damaged or missing.

B. Maintenance Tasks-Qualified Service Technician

The following tasks must be performed by a qualified service technician.

Gasket Seal and Glass Assembly Inspection

Frequency: Annually

By: Qualified Service Technician

Tools needed: Protective gloves, drop cloth and a stable work surface.

- Inspect gasket seal and its condition.
- Inspect fixed glass assembly for scratches and nicks that can lead to breakage when exposed to heat.
- Confirm there is no damage to glass or glass frame. Replace as necessary.
- Verify that fixed glass assembly is properly retained and attachment components are intact and not damaged. Replace as necessary.

Logs

Frequency: Annually

By: Qualified Service Technician

Tools needed: Protective gloves.

- Inspect for damaged or missing logs. Replace as necessary. Refer to Section 14 for log placement instructions.
- Verify correct log placement and no flame impingement causing sooting. Correct as necessary.

Firebox

Frequency: Annually

By: Qualified Service Technician

Tools needed: Protective gloves, sandpaper, steel wool, cloths, mineral spirits, primer and touch-up paint.

- Inspect for paint condition, warped surfaces, corrosion or perforation. Sand and repaint as necessary.
- Replace fireplace if firebox has been perforated.

Control Compartment and Firebox Top

Frequency: Annually

By: Qualified Service Technician

Tools needed: Protective gloves, vacuum cleaner, dust cloths

- Vacuum and wipe out dust, cobwebs, debris or pet hair. Use caution when cleaning these areas. Screw tips that have penetrated the sheet metal are sharp and should be avoided.
- Remove all foreign objects.
- Verify unobstructed air circulation.

Burner Ignition and Operation

Frequency: Annually

By: Qualified Service Technician

Tools needed: Protective gloves, vacuum cleaner, whisk broom, flashlight, voltmeter, indexed drill bit set, and a manometer.

- Verify burner is properly secured and aligned with pilot or igniter.
- Clean off burner top, inspect for plugged ports, corrosion or deterioration. Replace burner if necessary.
- Replace Glowing embers with new dime-size pieces. **DO NOT** block ports or obstruct lighting paths. Refer to Section 14 for proper ember placement.
- Verify batteries have been removed from battery back-up IPI systems to prevent premature battery failure or leaking.
- Check for smooth lighting and ignition carryover to all ports. Verify that there is no ignition delay.
- Inspect for lifting or other flame problems.
- Verify air shutter setting is correct. See Section 14 for required air shutter setting. Verify air shutter is clear of dust and debris.
- Inspect orifice for soot, dirt and corrosion. Verify orifice size is correct. See Service Parts List for proper orifice sizing.
- Verify manifold and inlet pressures. Adjust regulator as required.
- Inspect pilot flame pattern and strength. See Figure 3.1 for proper pilot flame pattern. Clean or replace orifice spud as necessary.
- Inspect IPI flame sensing rod for soot, corrosion and deterioration. Clean with emery cloth or replace as required.
- Verify that there is not a short in flame sense circuit by checking continuity between pilot hood and flame sense rod. Replace pilot as necessary.

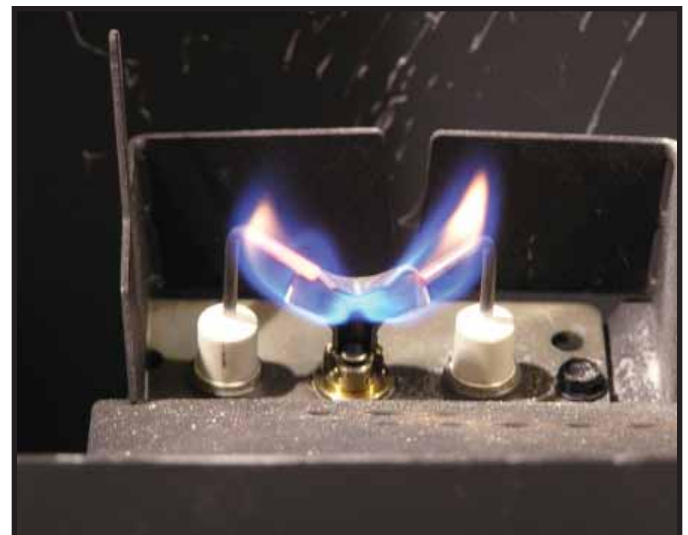

Figure 3.1 IPI Pilot Flame Patterns

C. Refractory, Grate and Valve Assembly Removal

It may become necessary to remove the optional refractory, grate and valve assemblies. This task should be performed by a qualified service technician. The optional refractory, grate and base refractory do not need to be removed to service the burner assembly.

NOTICE: Remove optional refractory before removing grate. If grate is removed first, damage to refractory will occur.

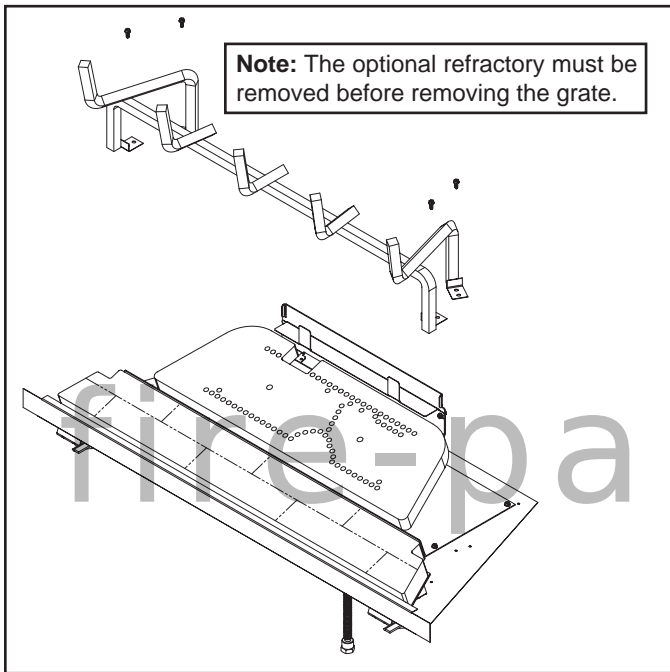

Figure 3.2 Grate Removal

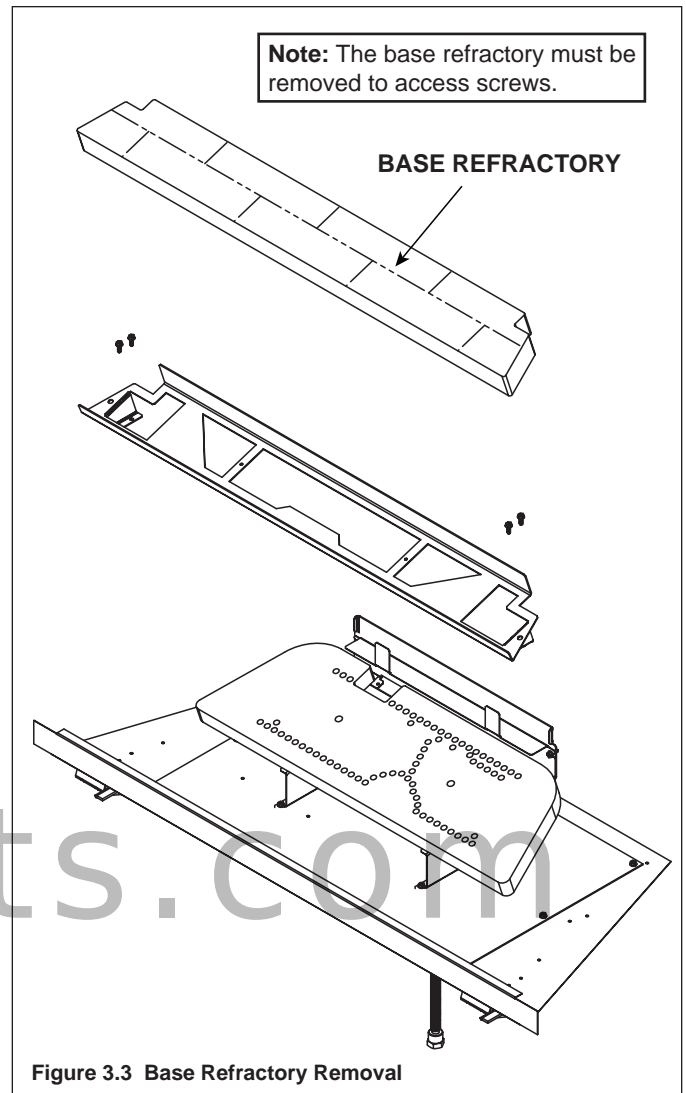

Figure 3.3 Base Refractory Removal

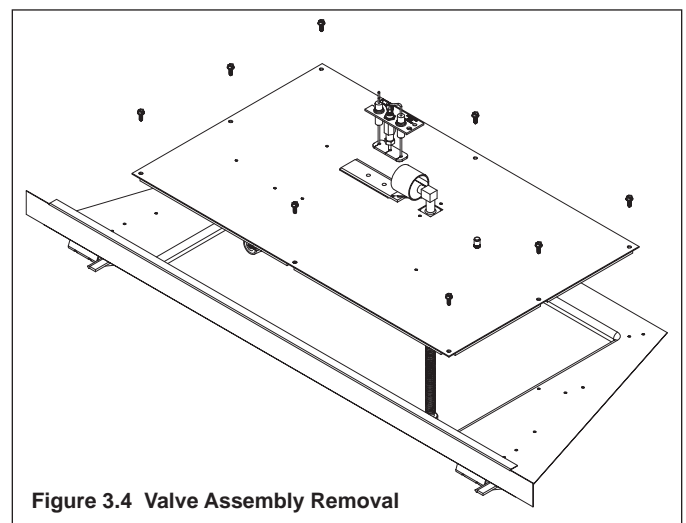

Figure 3.4 Valve Assembly Removal

D. Burner Identification/Verification

The burner may be accessed for identification and verification purposes. This task should be performed by a qualified service technician. The base refractory, valve plate, optional refractory and grate do not need to be removed to access the burner assembly. The logs and fiber burner top need to be removed to access the burner. Disconnect the pilot from the burner before removal. See Figure 3.5 for burner identification chart. Notch patterns are located on bottom side of burner.

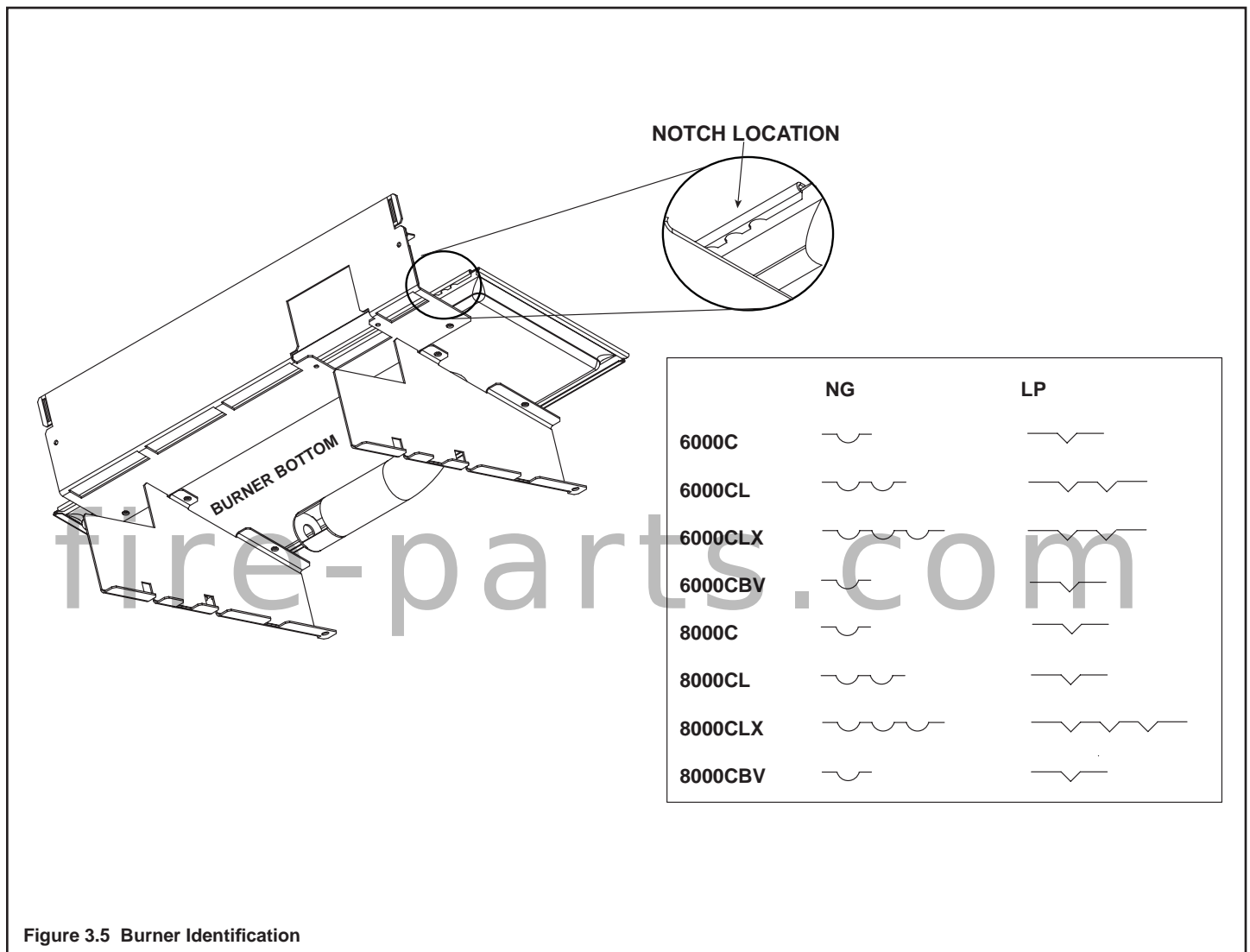

Figure 3.5 Burner Identification

4 Getting Started

Installer Guide

A. Typical Appliance System

NOTICE: Illustrations and photos reflect typical installations and are for design purposes only. Illustrations/diagrams are not drawn to scale. Actual product may vary from pictures in manual

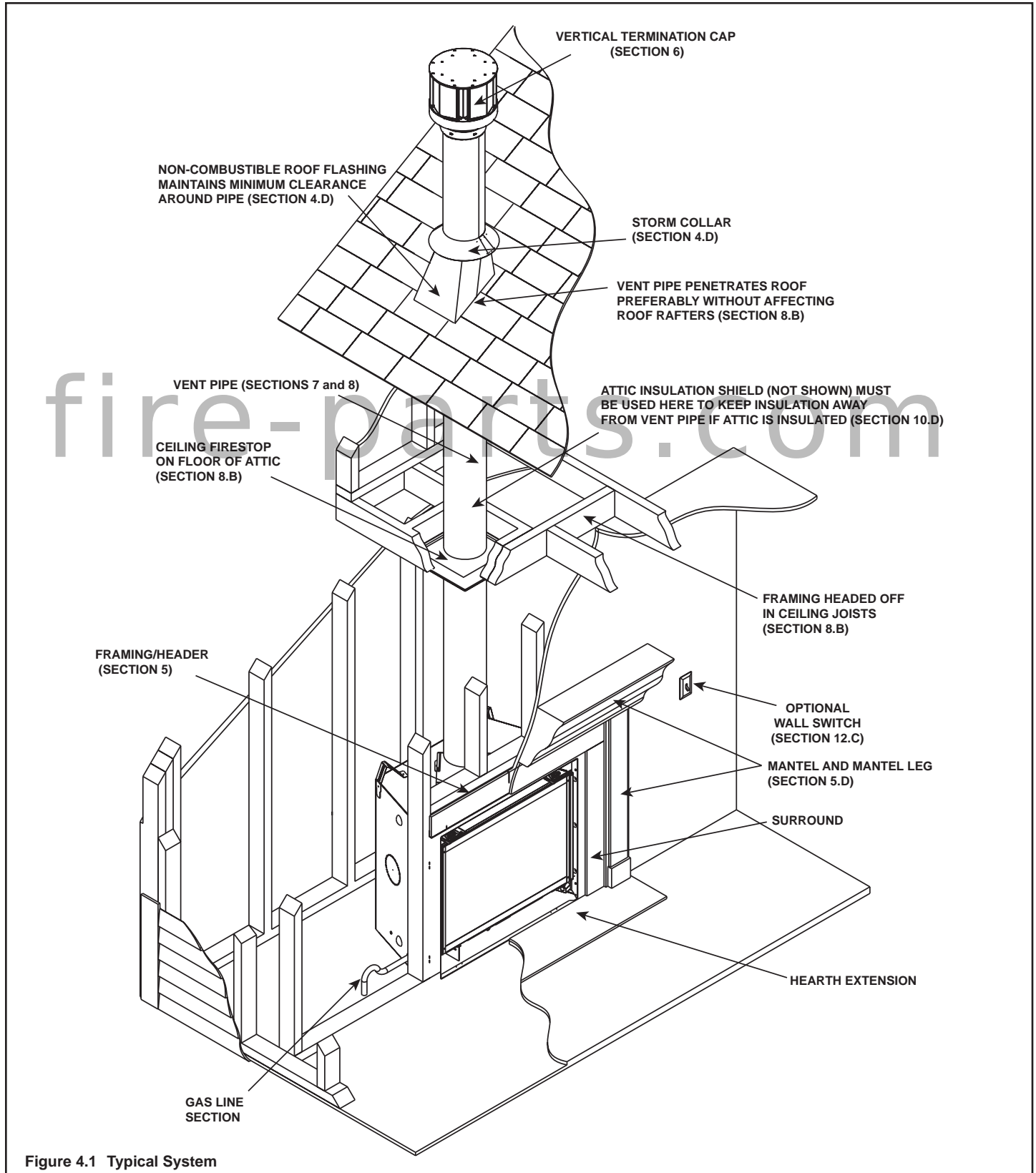

Figure 4.1 Typical System

B. Design and Installation Considerations

Heat & Glo B-type vent gas appliances are designed to operate with all exhaust gases expelled to the outside of the building, and combustion air pulled from the room.

Installation MUST comply with local, regional, state and national codes and regulations. Consult insurance carrier, local building inspector, fire officials or authorities having jurisdiction over restrictions, installation inspection and permits.

Before installing, determine the following:

- Where the appliance is to be installed.
- The vent system configuration to be used.
- Gas supply piping requirements.
- Electrical wiring requirements.
- Framing and finishing details.
- Whether optional accessories—devices such as a fan, wall switch, or remote control—are desired.

Improper installation, adjustment, alteration, service or maintenance can cause injury or property damage. For assistance or additional information, consult a qualified service technician, service agency or your dealer.

C. Tools and Supplies Needed

Before beginning the installation be sure that the following tools and building supplies are available.

| | |
|--------------|------------------------------------|
| Tape measure | Framing material |
| Pliers | High temperature caulking material |
| Hammer | Phillips screwdriver |
| Gloves | Framing square |
| Voltmeter | Electric drill and bits (1/4 in.) |
| Plumb line | Safety glasses |
| Level | Reciprocating saw |
| Manometer | Flat blade screwdriver |

Noncorrosive leak check solution
1/2 - 3/4 in. length, #6 or #8 Self-drilling screws
One 1/4 in. female connection (for optional fan).

D. Inspect Appliance and Components

The following B-vent components are needed for installation.

- Fireplace Box
- Pipe Components
- Firestops
- Attic Insulation Shield
- Elbows
- Strapping
- Roof Flashing or Chase Top
- Termination Cap
- Storm Collar
- Carefully remove the appliance and components from the packaging.

- The vent system components and decorative doors and fronts may be shipped in separate packages.
- If packaged separately, the log set and appliance grate must be installed.
- Report to your dealer any parts damaged in shipment, particularly the condition of the glass.
- **Read all of the instructions before starting the installation. Follow these instructions carefully during the installation to ensure maximum safety and benefit.**

WARNING! Risk of Fire or Explosion! Damaged parts could impair safe operation. **DO NOT** install damaged, incomplete or substitute components. Keep appliance dry.

Hearth & Home Technologies disclaims any responsibility for, and the warranty will be voided by, the following actions:

- Installation and use of any damaged appliance or vent system component.
- Modification of the appliance or vent system.
- Installation other than as instructed by Hearth & Home Technologies.
- Improper positioning of the gas logs or the glass door.
- Installation and/or use of any component part not approved by Hearth & Home Technologies.

Any such action may cause a fire hazard.

WARNING! Risk of Fire, Explosion or Electric Shock! DO NOT use this appliance if any part has been under water. Call a qualified service technician to inspect the appliance and to replace any part of the control system and/or gas control which has been under water.

E. Negative Pressure

WARNING! Asphyxiation Risk! Negative pressure can cause spillage of combustion fumes and soot. Fireplace needs to draft properly for safety.

Draft is the pressure difference needed to vent fireplaces successfully. Considerations for successful draft include:

- Preventing negative pressure
- Location of fireplace and chimney

Negative pressure results from the imbalance of air available for the fireplace to operate properly. Causes for this imbalance include:

- Exhaust fans (kitchen, bath, etc.)
- Range hoods
- Combustion air requirements for furnaces, water heaters and other combustion appliances
- Clothes dryers
- Location of return-air to furnace or air conditioning
- Imbalances of the HVAC air handling system
- Upper level air leaks (recessed lighting, attic hatch opening, duct leaks)

To minimize the effects of negative air pressure, the following must be considered:

- Install the fresh air kit. Install the intake on the side of the house towards prevailing winds during the heating season.

- Ensure adequate outdoor air is supplied for combustion appliances and exhaust equipment.
- Ensure furnace and air conditioning return vents are not located in the immediate vicinity of the fireplace.
- Avoid installing the fireplace near doors, walkways or small isolated spaces.
- Recessed lighting should be of “sealed can” design; attic hatches weather stripped or sealed; and attic mounted ductwork and air handler joints and seams taped or sealed.
- Basement installations should be avoided due to stack effect. Stack effect creates negative pressure in lower levels. Hearth & Home Technologies recommends the use of direct vent fireplaces in basements.

Location of the fireplace and chimney will affect performance. As shown in Figure 4.2, the chimney should:

- Be installed through the warm space enclosed by the building envelope. This helps to produce more draft, especially during lighting and die-down of the fire.
- Penetrate the highest part of the roof. This minimizes the effects of wind turbulence.
- Be located away from trees, adjacent structures, uneven roof lines and other obstructions.

Offsets restrict draft so their use should be minimized. Consider the fireplace location relative to floor and ceiling and attic joists.

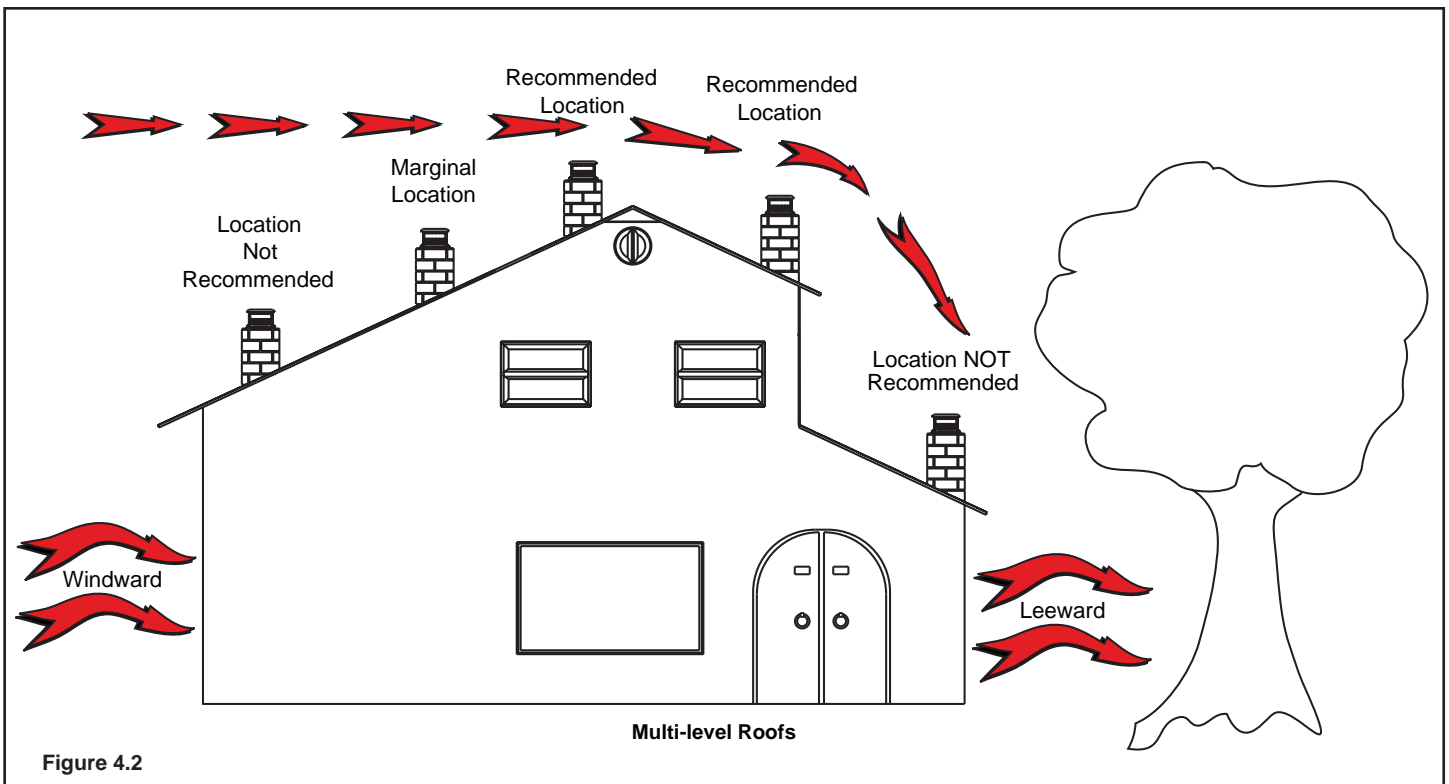

Figure 4.2

5 Framing and Clearances

A. Selecting Appliance Location

When selecting a location for the appliance it is important to consider the required clearances to walls (see Figure 5.1).

WARNING! Risk of Fire or Burns! Provide adequate clearance around air openings and for service access. Due to high temperatures, the appliance should be located out of traffic and away from furniture and draperies.

NOTICE: Illustrations reflect typical installations and are FOR DESIGN PURPOSES ONLY. Illustrations/diagrams are not drawn to scale. Actual installation may vary due to individual design preference.

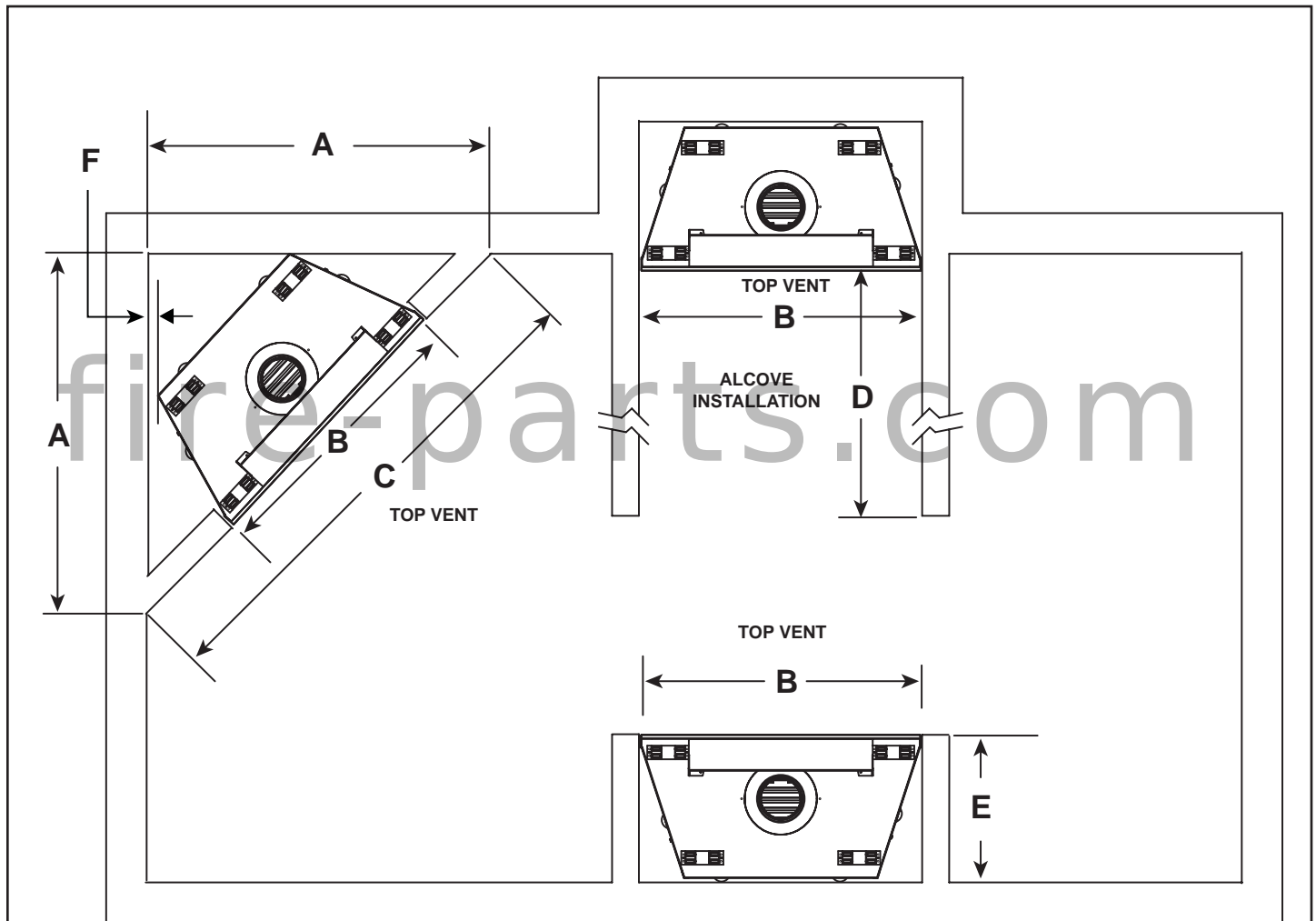

| 6000CBV | A | B | C | D | E | F |
|-------------|------|------|------|------------------------|-----|-----|
| Inches | 51 | 42 | 72 | See Mantel Projections | 22 | 1/2 |
| Millimeters | 1295 | 1067 | 1829 | | 559 | 13 |

| 8000CBV | A | B | C | D | E | F |
|-------------|--------|------|------|------------------------|-----|-----|
| Inches | 55-7/8 | 49 | 79 | See Mantel Projections | 22 | 1/2 |
| Millimeters | 1419 | 1245 | 2007 | | 559 | 13 |

Figure 5.1 Appliance Locations

B. Constructing the Appliance Chase

A chase is a vertical box-like structure built to enclose the gas appliance and/or its vent system. In cooler climates the vent should be enclosed inside the chase.

NOTICE: Treatment of ceiling firestops and wall shield firestops and construction of the chase may vary with the type of building. These instructions are not substitutes for the requirements of local building codes. Therefore, you **MUST** check local building codes to determine the requirements to these steps.

Chases should be constructed in the manner of all outside walls of the home to prevent cold air drafting problems. The chase should not break the outside building envelope in any manner.

Walls, ceiling, base plate and cantilever floor of the chase should be insulated. Vapor and air infiltration barriers should be installed in the chase as per regional codes for the rest of the home. Additionally, in regions where cold air infiltration may be an issue, the inside surfaces may be sheetrocked and taped for maximum air tightness.

To further prevent drafts, the wall shield and ceiling fire-

stops should be caulked with high temperature caulk to seal gaps. Gas line holes and other openings should be caulked with high temperature caulk or stuffed with unfaced insulation. If the appliance is being installed on a cement surface, a layer of plywood may be placed underneath to prevent conducting cold up into the room.

C. Clearances

NOTICE: Install appliance on hard metal or wood surfaces extending full width and depth. **DO NOT** install directly on carpeting, vinyl, tile or any combustible material other than wood.

WARNING! Risk of Fire! Maintain specified air space clearances to appliance and vent pipe:

- Insulation and other materials must be secured to prevent accidental contact.
- The chase must be properly blocked to prevent blown insulation or other combustibles from entering and making contact with fireplace or chimney.
- Failure to maintain airspace may cause overheating and a fire.

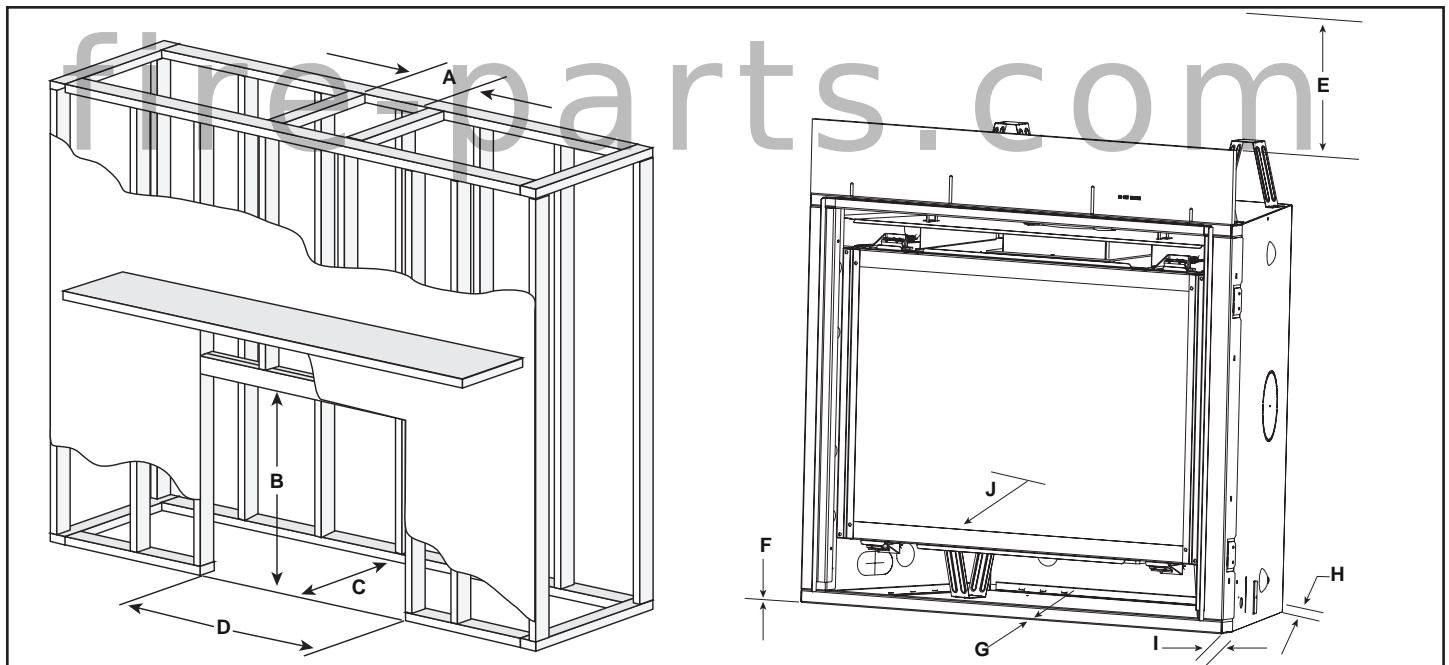

| | | * MINIMUM FRAMING DIMENSIONS | | | | | | | | | |
|---------|-------------|------------------------------|------------------------|-----------------------|-----------------------|----------------------|-------------------|----------------------|------------------|--------------------|--------------------|
| | | A | B | C | D | E | F | G | H | I | J |
| | | Rough Opening (Vent Pipe) | Rough Opening (Height) | Rough Opening (Depth) | Rough Opening (Width) | Clearance to Ceiling | Combustible Floor | Combustible Flooring | Behind Appliance | Sides of Appliance | Front of Appliance |
| 6000CBV | Inches | 10 | 40-1/8 | 22 | 42 | 25 | 0 | 0 | 1/2 | 1/2 | 36 |
| | Millimeters | 254 | 1019 | 559 | 1067 | 635 | 0 | 0 | 13 | 13 | 914 |
| 8000CBV | Inches | 10 | 42-1/8 | 22 | 49 | 25 | 0 | 0 | 1/2 | 1/2 | 36 |
| | Millimeters | 254 | 1070 | 559 | 1245 | 635 | 0 | 0 | 13 | 13 | 914 |

* Adjust framing dimensions for interior sheathing (such as sheetrock)

Figure 5.2 Clearances to Combustibles

D. Mantel and Wall Projections

WARNING! Risk of Fire! Comply with all minimum clearances as specified. Framing or finishing material closer than the minimums listed must be constructed entirely of noncombustible materials (i.e., steel studs, concrete board, etc).

Combustible Mantels

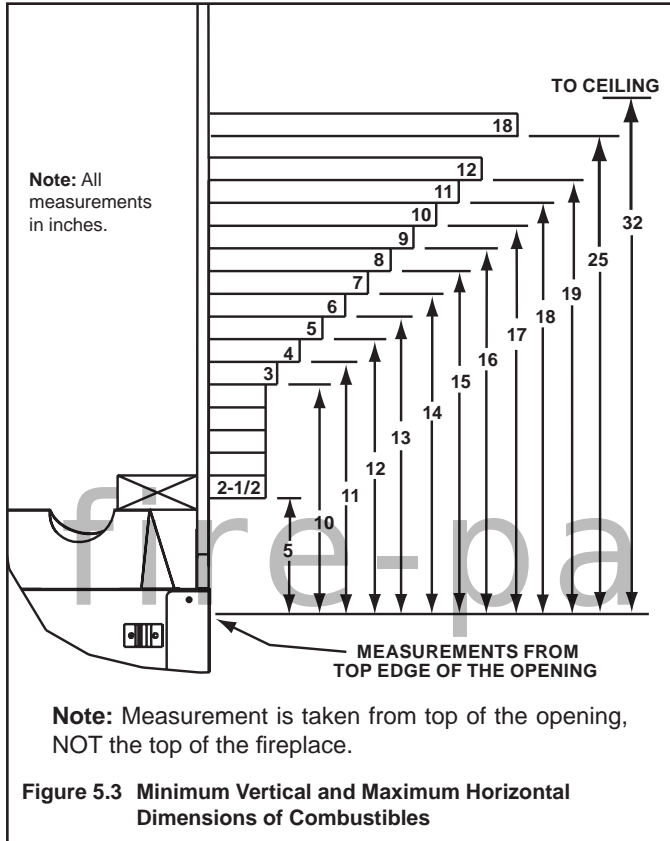

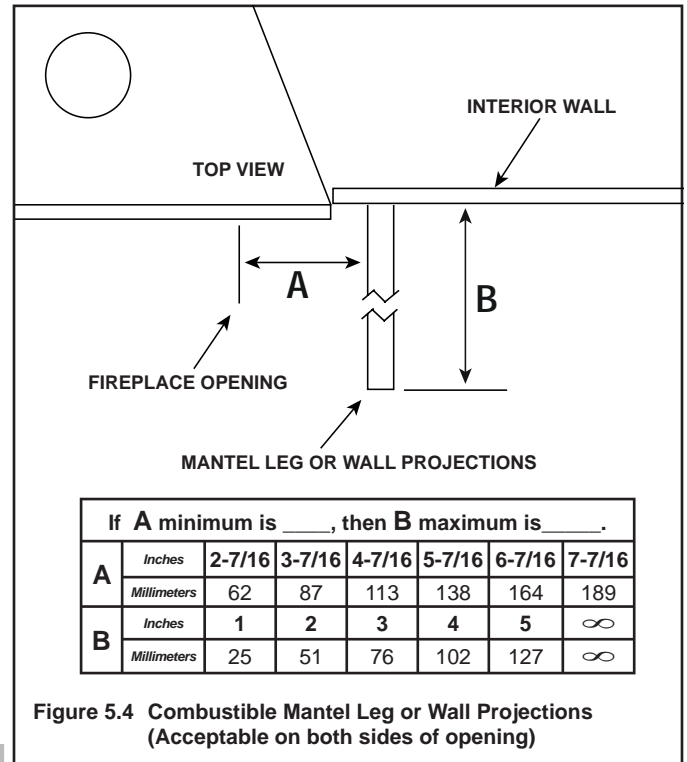

Combustible Mantel Legs or Wall Projections



6 Termination Locations

A. Vent Termination Minimum Clearances

 **WARNING**



Fire Risk.

Maintain vent clearance to combustibles as specified.

- **DO NOT** pack air space with insulation or other materials.

Failure to keep insulation or other materials away from vent pipe may cause overheating and fire.

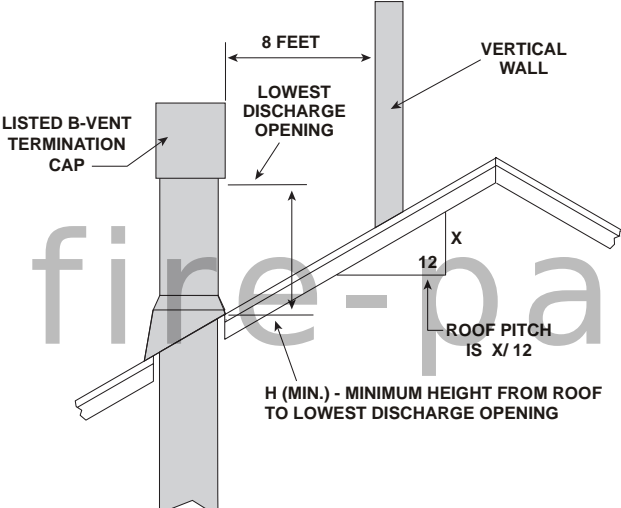

H (MIN.) - MINIMUM HEIGHT FROM ROOF TO LOWEST DISCHARGE OPENING

| Roof Pitch | H (Min.) Ft. |
|--------------------------|--------------|
| Flat to 6/12..... | 1.0* |
| Over 6/12 to 7/12..... | 1.25* |
| Over 7/12 to 8/12..... | 1.5* |
| Over 8/12 to 9/12..... | 2.0* |
| Over 9/12 to 10/12..... | 2.5 |
| Over 10/12 to 11/12..... | 3.25 |
| Over 11/12 to 12/12..... | 4.0 |
| Over 12/12 to 14/12..... | 5.0 |
| Over 14/12 to 16/12..... | 6.0 |
| Over 16/12 to 18/12..... | 7.0 |
| Over 18/12 to 20/12..... | 7.5 |
| Over 20/12 to 21/12..... | 8.0 |

* 3 foot minimum in snow regions

Figure 6.1 Minimum Height From Roof To Lowest Discharge Opening

| A | B |
|---|--------------------------|
| 6 in. (minimum) up to 20 in. 152 mm/508 mm | 18 in. minimum 457 mm |
| 20 in. and over | 0 in. minimum |

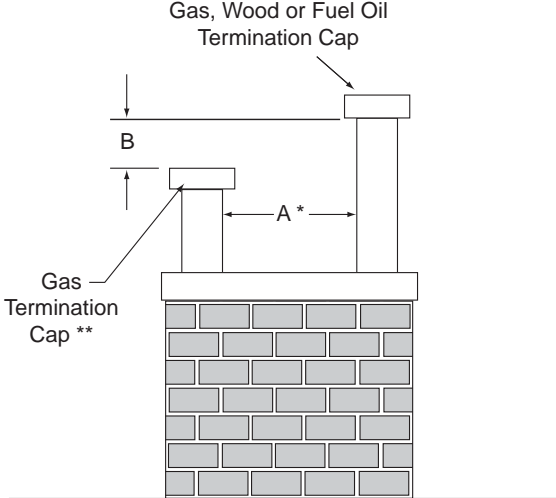

Gas, Wood or Fuel Oil Termination Cap

Gas Termination Cap **

* If using decorative cap cover(s), this distance may need to be increased. Refer to the installation instructions supplied with the decorative cap cover.

** In a staggered installation with both gas and wood terminations, the wood termination cap must be higher than the gas termination cap.

Figure 6.2 Staggered Termination Caps

7 Vent Information and Diagrams

A. Vent Guidelines

WARNING! Fire Risk/Asphyxiation! This appliance requires the specified pipe for operation. Incorrect pipe may cause spillage, condensation and overheating.

These models require the following size B-vent double wall, or single wall rigid or flex vent pipe.

| Model | Pipe Size |
|-------------|-----------|
| 8000CBV-IPI | 6 inch |
| 6000CBV-IPI | 6 inch |

- Follow pipe manufacturer's installation guidelines when installing the appliance.

WARNING! Fire Risk/Explosion/Asphyxiation! DO NOT connect this gas appliance to a chimney flue serving a separate solid-fuel or gas burning appliance.

- Vent this appliance directly outside.
- Use separate vent system for this appliance.

May impair safe operation of this appliance or other appliances connected to the flue.

B. Vent System Configuration

CAUTION! Risk of Fire! ALL vent configuration specifications MUST be followed. This product is tested and listed to these specifications. Appliance performance will suffer if specifications are not followed.

Rise to Run Ratio = 2:1

Maximum Total Horizontal Run = 15 Feet

Minimum Total Vertical Rise = 9 Feet

Maximum Total Vertical Rise = 30 Feet

Maximum Number of Elbows: Two 90° or Four 45°

WARNING! Risk of Fire or Explosion! Insulation and other combustibles must not infringe on clearances.

- ALWAYS maintain specified clearances around venting and firestop systems.
- Install firestops as specified.

Failure to keep insulation or other material away from vent pipe may cause fire.

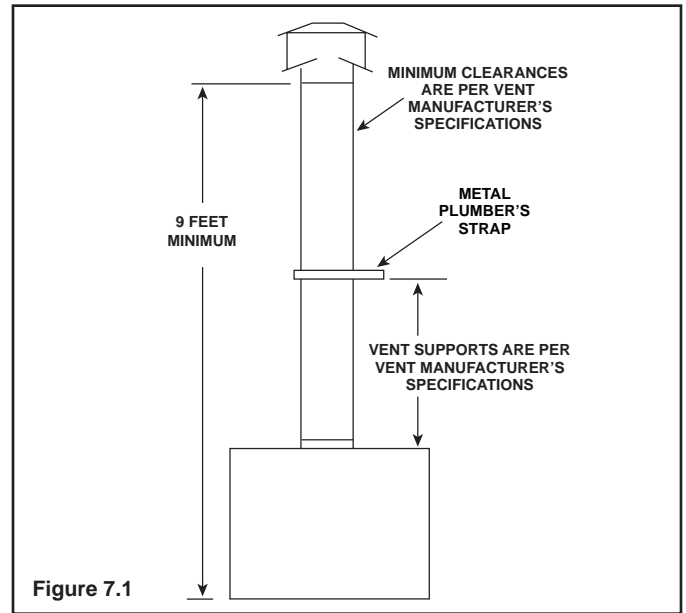

Figure 7.1

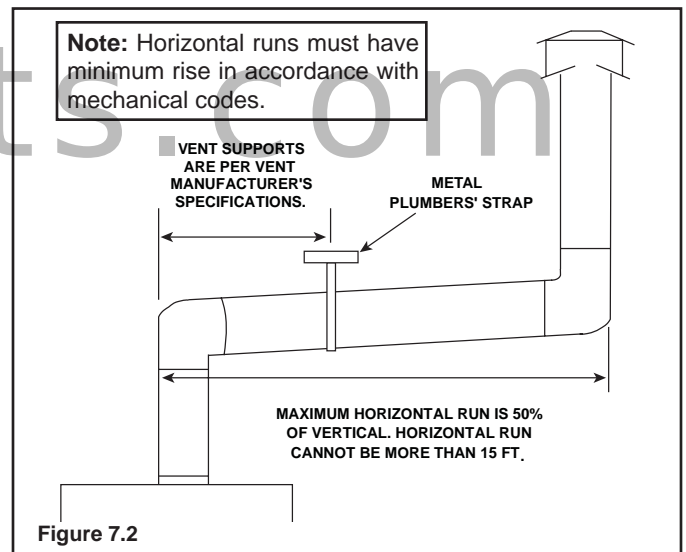

Figure 7.2

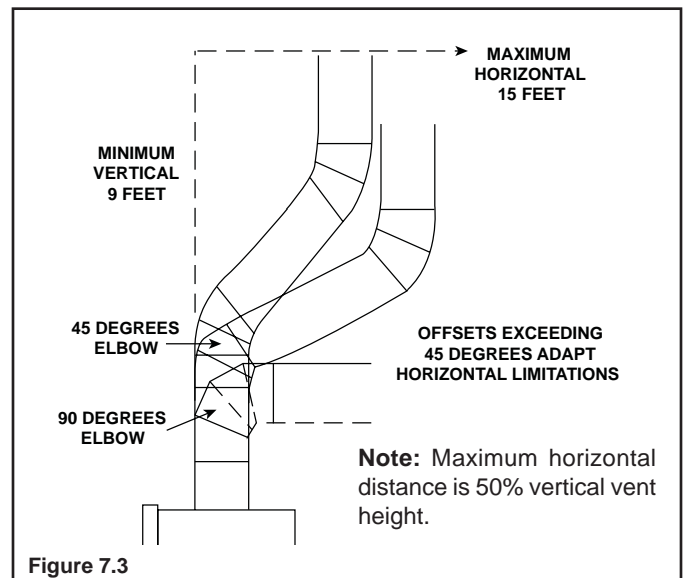

Figure 7.3

8 Vent Clearances and Framing

A. Pipe Clearances to Combustibles

Vent clearances are per vent manufacturer's specifications. MUST be Listed B-Vent pipe.

WARNING! Risk of Fire! Maintain air space clearance to vent. **DO NOT** pack insulation or other combustibles:

- Between ceiling firestops
- Between wall shield firestops
- Around vent system

Failure to keep insulation or other material away from vent pipe may cause over heating and fire.

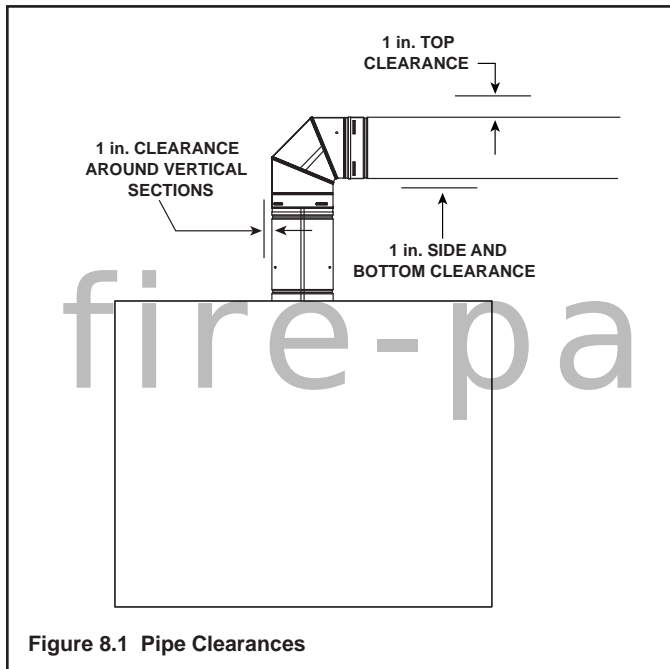

B. Wall and Ceiling Penetration Framing

For a wall or ceiling penetration consult B-vent pipe manufacturer's instructions to provide adequate clearances. Use same size framing materials as those used in the wall or ceiling construction. Firestop spacers must be used in wall and ceiling penetrations per the B-Vent pipe manufacturer's specifications and national, regional and local codes.

Note: MUST terminate vertically.

C. Vertical Penetration Framing

WARNING! Fire Risk. DO NOT allow loose materials or insulation to touch vent. Hearth & Home Technologies Inc. requires the use of an attic shield.

The National Fuel Gas Code ANSI Z223.1 and NFPA 54 requires an attic shield constructed of 26 gauge minimum metal that extends at least 2 in. (51 mm) above insulation.

Attic shields must meet specified clearance and be secured in place.

Use B-vent manufacturer's firestops to provide adequate clearances.

9 Appliance Preparation

A. Installing Outside Air Kit Damper Assembly

CAUTION! Risk of Cuts/Abrasions/Flying Debris. Wear protective gloves and safety glasses during installation. Sheet metal edges are sharp.

WARNING! Risk of Fire/Asphyxiation. DO NOT draw outside combustion air from:

- Wall, floor or ceiling cavity.
- Enclosed space such as an attic or garage.
- Close proximity to exhaust vents or chimneys.

Fumes or odor may result.

- Remove and discard cover plate or knockout from side of appliance.
- Open air kit damper slightly.
- Locate door hinge toward back of appliance (see Figure 9.1).

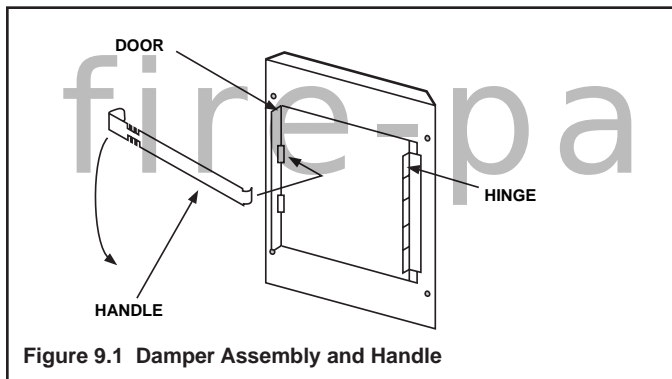

- Attach damper assembly to appliance using screws provided (see Figure 9.2).
- Insert narrow end of handle through tab and into upper slot of door.
- Check handle operation. Pull handle out to open, and in to close.

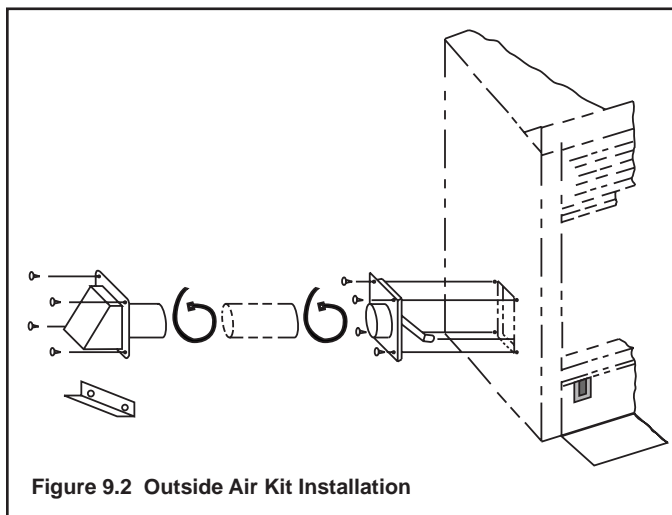

B. Gas and Electrical Connections

If applicable, ensure that gas and electrical connections are installed at this time. Refer to Sections 11 (Gas Information) and 12 (Electrical Information).

C. Installing the Non-combustible Board

The factory supplied non-combustible board spans the distance from the top of the fireplace to the center of the framing header. This board must be used. See figure 9.3.

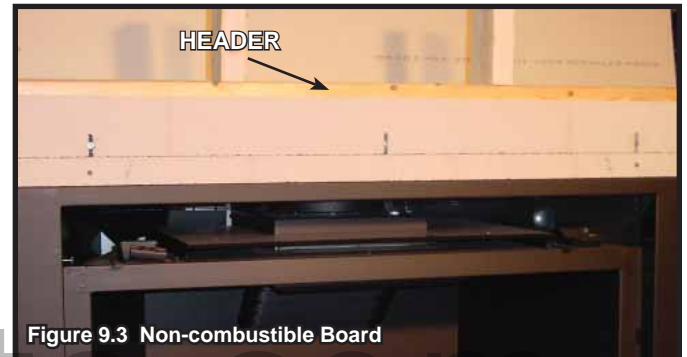

D. Securing and Leveling the Appliance

WARNING! Risk of Fire! Prevent contact with:

- Sagging or loose insulation
- Insulation backing or plastic
- Framing and other combustible materials

Block openings into the chase to prevent entry of blown-in insulation. Make sure insulation and other materials are secured.

DO NOT notch the framing around the appliance standoffs.

Failure to maintain air space clearance may cause overheating and fire.

The diagram shows how to properly position and secure the appliance (see Figure 9.4). Nailing tabs are provided to secure the appliance to the framing members.

- Bend out nailing tabs on each side.
- Place the appliance into position.
- Keep nailing tabs flush with the framing.
- Level the appliance from side to side and front to back.
- “Square” the unit by securing diagonal dimensions to within 1/4 inch of each other. See Figure 9.5.
- Shim the appliance as necessary. It is acceptable to use wood shims underneath the appliance.
- Secure the appliance to the framing by using nails or screws through the nailing tabs.
- Secure the appliance to the floor by inserting two screws through the pilot holes at the bottom of the appliance.

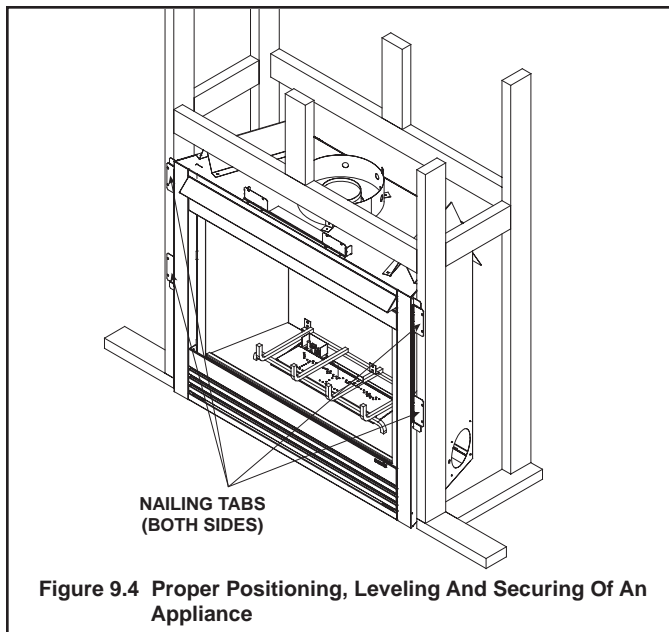
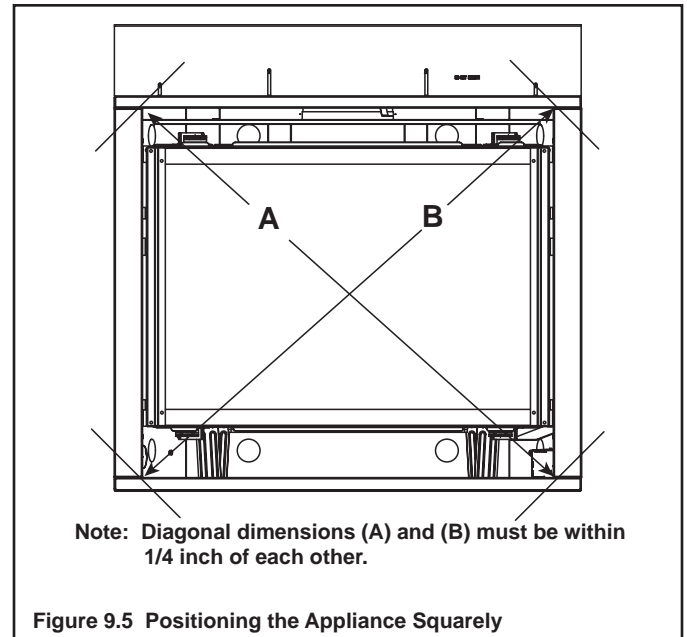

10 Installing Vent Pipe

A. Assembly of Vent Sections

This B-Vent appliance requires 6 inch B-vent double-wall pipe. Follow the pipe manufacturer's installation guidelines when installing the unit. This will ensure proper operation and prevent safety hazards.

WARNING! Risk of Fire/Exhaust Fumes! Assemble pipe sections per B-vent manufacturer's instructions. Use support tabs for screws. Pipe may separate if not properly joined.

B. Attaching Vent to Firebox

Attach the first B-Vent component to the flue outlet collar using 3 self-tapping screws. See Figure 10.1.

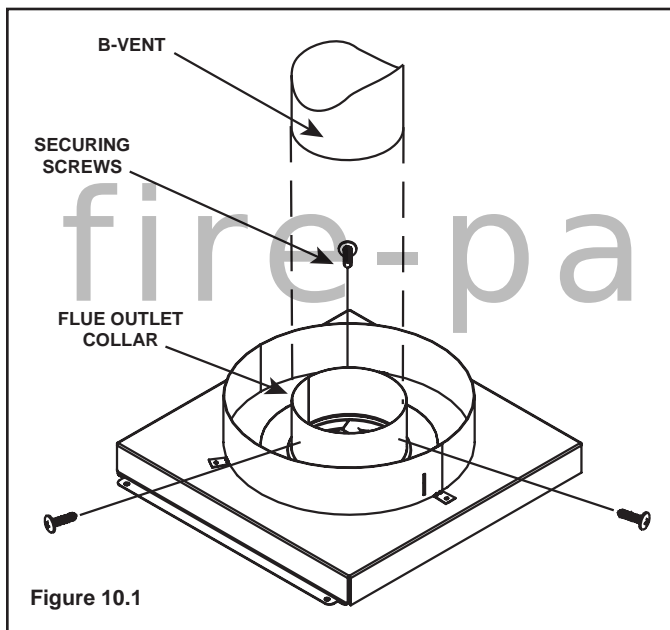

C. Securing Vent Sections

Secure vent sections with vent supports following B-vent manufacturer's instructions.

WARNING! Risk of Fire or Explosion! Use vent run supports per vent manufacturer's installation instructions.

- Connect vent sections per vent manufacturer's installation instructions.
- Maintain all clearances to combustibles. Maintain specified slope (if required).
- Improper support may allow vent to sag or separate.

D. Install Attic Insulation Shield

WARNING! Fire Risk. DO NOT allow loose materials or insulation to touch vent. Hearth & Home Technologies Inc. requires the use of an attic shield.

The National Fuel Gas Code ANSI Z223.1 and NFPA 54 requires an attic shield constructed of 26 gauge minimum metal that extends at least 2 in. (51 mm) above insulation.

Attic shields must meet specified clearance and be secured in place.

11 Gas Information

A. Fuel Conversion

- Make sure the appliance is compatible with available gas types.
- Conversions must be made by a qualified service technician using Hearth & Home Technologies specified and approved parts.

B. Gas Pressure

- Optimum appliance performance requires proper input pressures.
- Gas line sizing requirements will be determined in ANSI Z223.1 National Fuel Gas Code in the USA and CAN/CGA B149 in Canada.
- Pressure requirements are:

| Gas Pressure | Natural Gas | Propane |
|------------------------|---------------|---------------|
| Minimum inlet pressure | 5.0 in. w.c. | 11.0 in. w.c. |
| Maximum inlet pressure | 10.0 in. w.c. | 13.0 in. w.c. |
| Manifold pressure | 3.5 in. w.c. | 10.0 in. w.c. |

WARNING! Risk of Fire or Explosion! High pressure will damage valve. Low pressure may cause explosion.

- Verify inlet pressures. Verify minimum pressures when other household gas appliances are operating.
- Install regulator upstream of valve if line pressure is greater than 1/2 psig.

| | |
|---|--|
| ⚠ WARNING | |
|  | <p>Fire Risk. Explosion Hazard. High pressure will damage valve.</p> <ul style="list-style-type: none">• Disconnect gas supply piping BEFORE pressure testing gas line at test pressures above 1/2 psig.• Close the manual shutoff valve BEFORE pressure testing gas line at test pressures equal to or less than 1/2 psig. |

Note: Have the gas supply line installed in accordance with local codes, if any. If not, follow ANSI 223.1. Installation should be done by a qualified installer approved and/or licensed as required by the locality. (In the Commonwealth of Massachusetts installation must be performed by a licensed plumber or gas fitter).

Note: A listed (and Commonwealth of Massachusetts approved) 1/2 in. (13 mm) T-handle manual shut-off valve and flexible gas connector are connected to the 1/2 in. (13 mm) control valve inlet.

- **If substituting for these components, please consult local codes for compliance.**

C. Gas Connection

- Refer to Reference Section 16 for location of gas line access in appliance.
- Gas line may be run through knockout(s) provided.
- The gap between supply piping and gas access hole may be caulked with high temperature caulk or stuffed with non-combustible, unfaced insulation to prevent cold air infiltration.
- Ensure that gas line does not come in contact with outer wrap of the appliance. Follow local codes.
- Pipe incoming gas line into valve compartment.
- Connect incoming gas line to the 1/2 in. (13 mm) connection on manual shutoff valve.

WARNING! Risk of Fire or Explosion! Support control when attaching pipe to prevent bending gas line.

- A small amount of air will be in the gas supply lines.

WARNING! Risk of Fire or Explosion! Gas build-up during line purge could ignite.

- Purge should be performed by qualified service technician.
- Ensure adequate ventilation.
- Ensure there are no ignition sources such as sparks or open flames.

Light the appliance. It will take a short time for air to purge from lines. When purging is complete the appliance will light and operate normally.

WARNING! Risk of Fire, Explosion or Asphyxiation! Check all fittings and connections with a non-corrosive commercially available leak-check solution. **DO NOT** use open flame. Fittings and connections could have loosened during shipping and handling.

WARNING! Risk of Fire! DO NOT change valve settings. This valve has been preset at the factory.

D. High Altitude Installations

NOTICE: If the heating value of the gas has been reduced, these rules do not apply. Check with your local gas utility or authorities having jurisdiction.

When installing above 2000 feet elevation:

- In the USA: Reduce burner orifice 4% for each 1000 feet above 2000 feet.
- In CANADA: Reduce burner orifice 10% for elevations between 2000 feet and 4500 feet. Above 4500 feet, consult local gas utility.

12 Electrical Information

A. Wiring Requirements

NOTICE: This appliance must be electrically wired and grounded in accordance with local codes or, in the absence of local codes, with **National Electric Code ANSI/NFPA 70-latest edition** or the **Canadian Electric Code CSA C22.1**.

- Wire the appliance junction box to 110-120 VAC. This is required for proper operation of the appliance (IntelliFire Plus™ ignition).
- A 110-120 VAC circuit for this product must be protected with ground-fault circuit-interrupter protection, in compliance with the applicable electrical codes, when it is installed in locations such as in bathrooms or near sinks.
- Low voltage and 110 VAC voltage cannot be shared within the same wall box.

WARNING! Risk of Shock or Explosion! DO NOT wire 110V to the valve or to the appliance wall switch. Incorrect wiring will damage controls.

B. IntelliFire Plus™ Ignition System Wiring

- Wire the appliance junction box to 110 VAC for proper operation of the appliance.

WARNING! Risk of Shock or Explosion! DO NOT wire IPI controlled appliance junction box to a switched circuit. Incorrect wiring will override IPI safety lockout.

- Refer to Figure 12.1, IntelliFire Plus™ Pilot Ignition (IPI) Wiring Diagram.
- This appliance is equipped with an IntelliFire Plus™ control valve which operates on a 6 volt system.
- Plug the 6 volt transformer plug into the appliance junction box to supply power to the unit OR install four AA cell batteries (not included) into the battery pack before use.

C. Optional Accessories Requirements

- This appliance may be used with a wall switch, wall mounted thermostat and/or a remote control.

Wiring for optional Hearth & Home Technologies approved accessories should be done now to avoid reconstruction. Follow instructions that come with those accessories.

- Use only IntelliFire Plus™ Wireless Controls or WSK-21 wired wall switch with the IntelliFire Plus™ Ignition System.
- A standard ON/OFF switch is compatible.

NOTE: 1. Ignition module, valve, pilot, and wall switch operate on 3 volts. 120 VAC is required at junction box unless equipped with battery back-up.

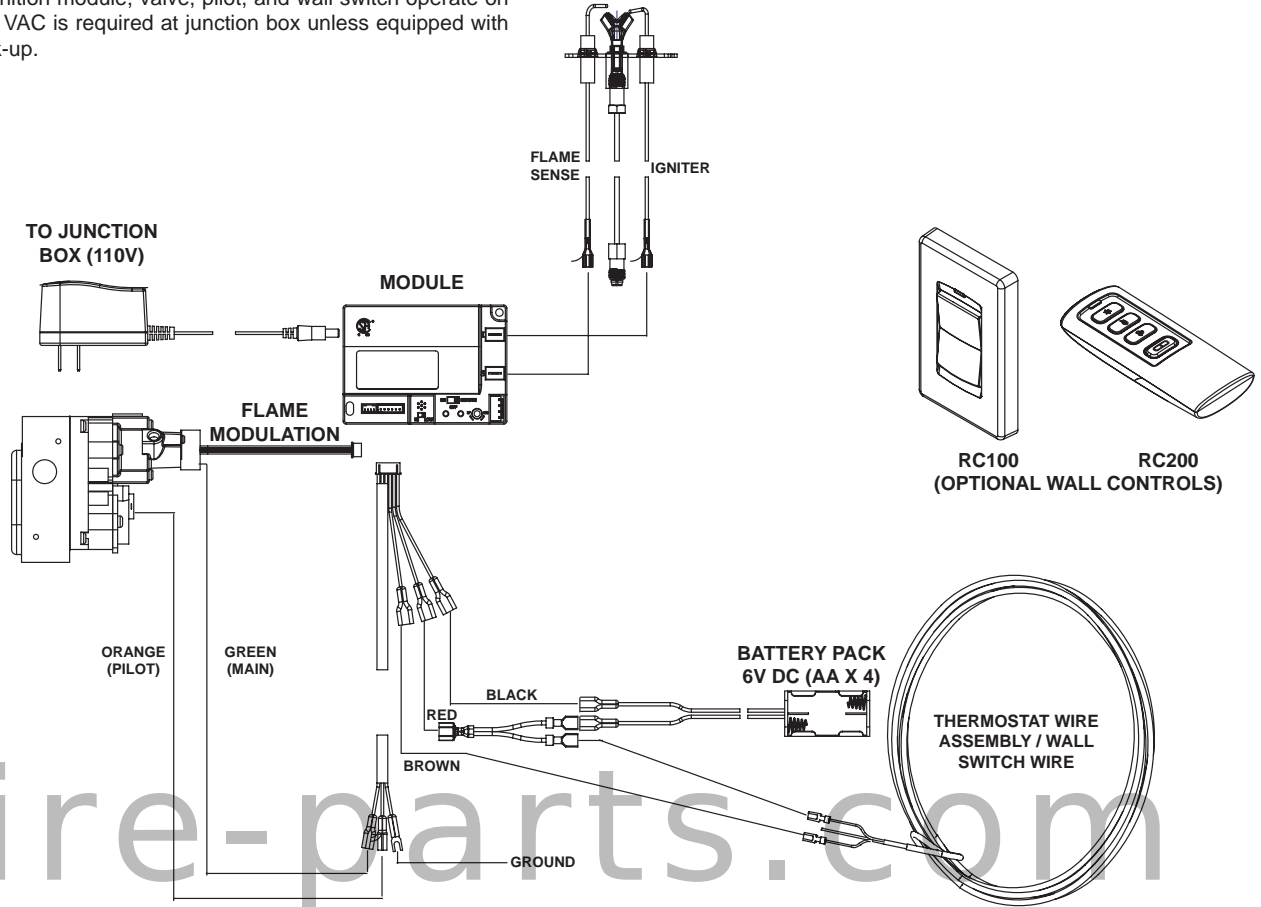

Figure 12.1 IPI Wiring Diagram

D. Electrical Service and Repair

WARNING! Risk of Shock! Label all wires prior to disconnection when servicing controls. Wiring errors can cause improper and dangerous operation. Verify proper operation after servicing.

WARNING! Risk of Shock! Replace damaged wire with type 105° C rated wire. Wire must have high temperature insulation.

E. Junction Box Installation

If the box is being wired from the **INSIDE** of the appliance:

- Remove the screw attaching the junction box/receptacle to the outer shell, rotate the junction box inward to disengage it from the outer shell (see Figure 12.2).
- Pull the electrical wires from outside the appliance through the opening into the valve compartment and secure wires with a Romex connector. See Figure 12.2.
- Make all necessary wire connections to the junction box/receptacle and reattach the junction box/receptacle to the outer shell.

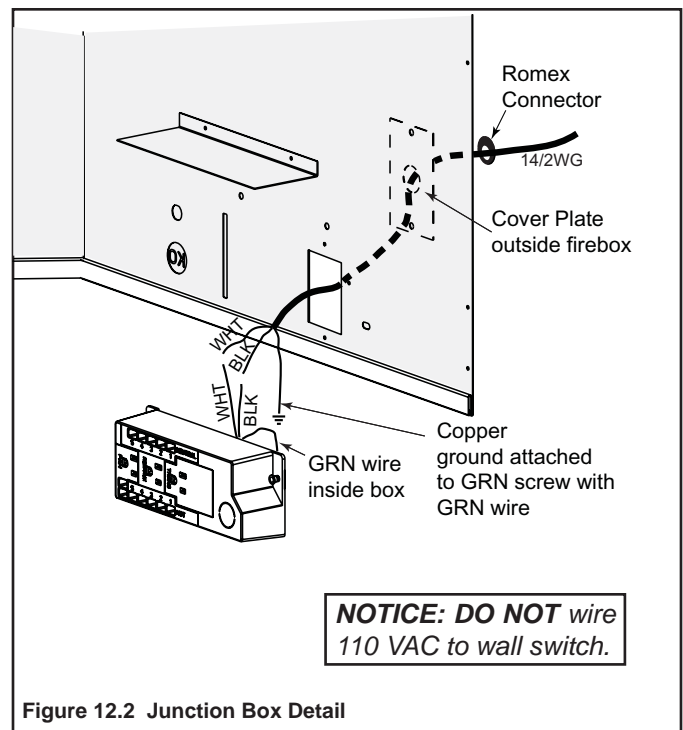

Figure 12.2 Junction Box Detail

F. Wall Switch Installation for Fan (Optional)

If the box is being wired to a wall mounted switch for use with a fan (See Figure 12.3):

- The power supply for the appliance must be brought into a switch box.
- The power can then be supplied from the switch box to the appliance using a minimum of 14-3 with ground wire.
- At the switch box connect the black (hot) wire and red (switch leg) wire to the wall switch as shown.
- At the appliance connect the black (hot), white (neutral) and green (ground) wires to the junction box as shown.
- Add a 1/4 in. insulated female connector to the red (switch leg) wire, route it through the knockout in the face of the junction box, and connect to the top fan switch connector (1/4 in. male) as shown.

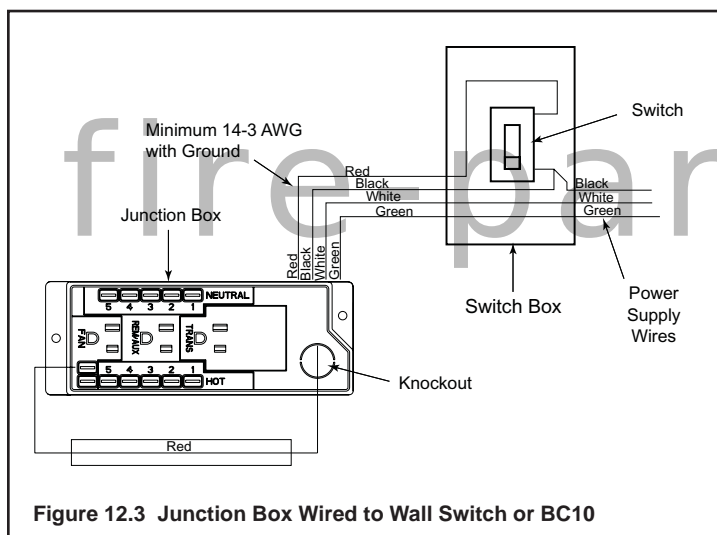

Figure 12.3 Junction Box Wired to Wall Switch or BC10

G. Control Module Operation

1. The control module has an ON/OFF/REMOTE selector switch that must be set. See Figure 12.4.

OFF Position: Appliance will ignore all power inputs and will not respond to any commands from a wall switch or remote. The unit should be in the OFF position during installation, service, battery installation, and in the event that the control goes into LOCK-OUT mode as a result of an error code.

ON Position: Appliance will ignite and run continuously in the HI flame setting, with no adjustment in flame output. This mode of operation is primarily used for initial installation or power outage operation with battery backup.

REMOTE Position: Appliance will initiate commands from a wired wall switch and/or one of the optional wireless remote options.

2. A wall switch can be wired into the control module brown and red wires. See Figure 12.1.
3. If using a wired wall switch with the module in REMOTE mode, the flame output can be adjusted with the HI/LO selector switch on the module. See Figure 12.4. Note that the flame HI/LO selector switch will become inactive once an optional remote control (RC200/RC300) is programmed to the control module. Note that the control module will always ignite the fireplace on HI and remain so for the initial 10 seconds of operation. If the HI/LO is switched to the LO position, the flame output will automatically drop to the lowest setting after the flame has been established for 10 sec. After this 10 second period, the flame can be adjusted from HI to LO with the switch.
4. The control module has safety feature that automatically shuts down the fireplace after 9 hours of continuous operation without receiving a command from the remote.
5. If you intend to use both a wired wall switch and an optional wireless wall switch to operate your fireplace, the wall switch will override any commands given by the remote.
6. The module has the capability to recognize potential malfunctions. If these occur, it will fail to ignite and/or respond to a command to ignite via the wall switch and/or remote. In this case, the module may have gone into LOCK-OUT mode. In this state, it will emit a RED/GREEN LED error code. To reset the error code, switch the selector to OFF, and then back to REMOTE or ON. If the ignition command again fails, the module will emit an LED error code, prior to going back into LOCK-OUT mode. Contact your dealer for service if this occurs.

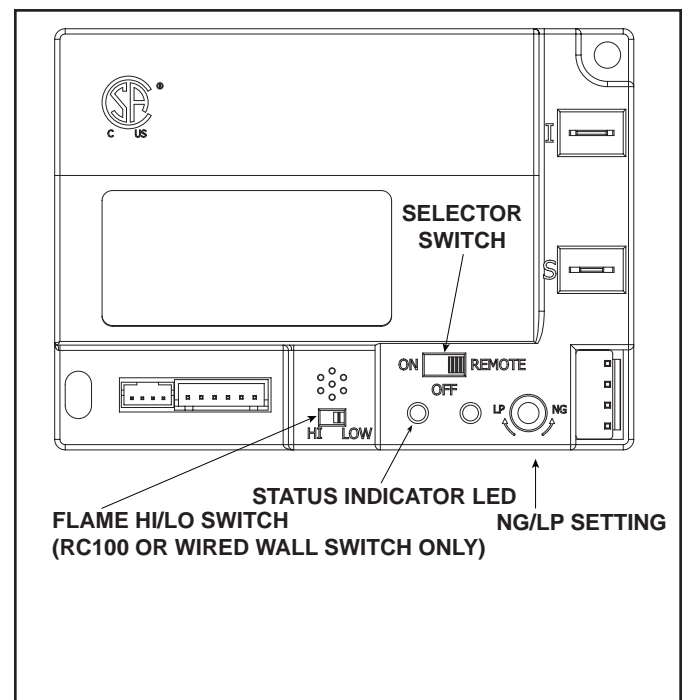

Figure 12.4 Control Module

13 Finishing

A. Mantel and Wall Projections

WARNING! Risk of Fire! Comply with all minimum clearances as specified. Framing closer than the minimums listed must be constructed entirely of noncombustible materials (i.e., steel studs, concrete board, etc.).

Combustible Mantels

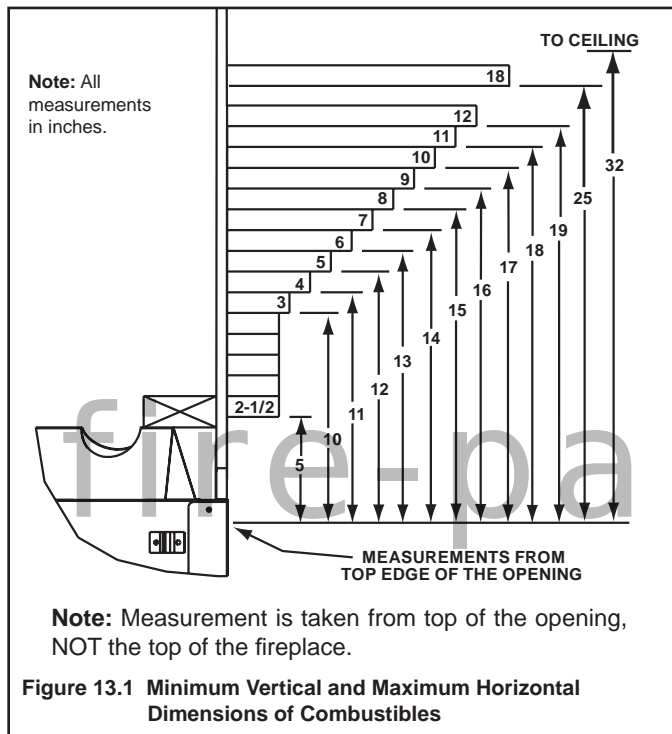

Combustible Mantel Legs or Wall Projections

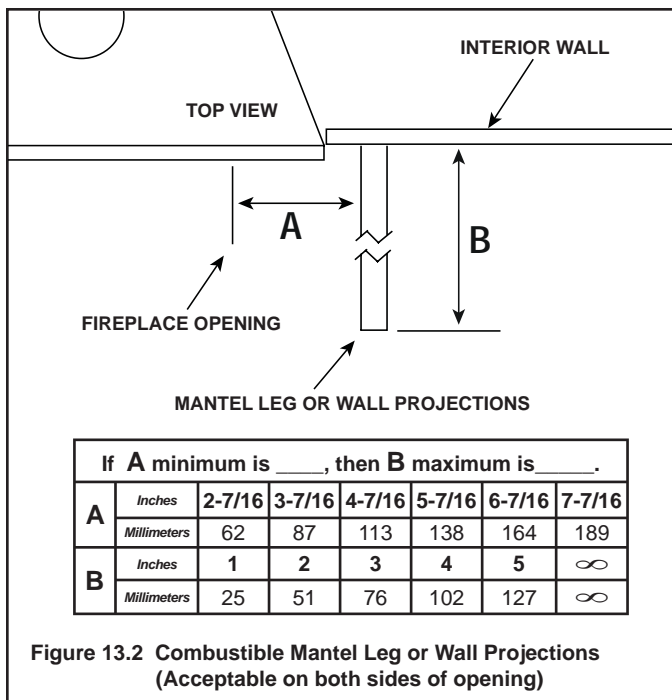

B. Facing Material

- Metal front faces may be covered with non-combustible materials only.
- Facing and/or finishing materials must not interfere with air flow through louvers, operation of louvers or doors, or access for service.
- Facing and/or finishing materials must never overhang into the glass opening.
- Observe all clearances when applying combustible materials.
- Seal joints between the finished wall and appliance top and sides using a 300 °F minimum sealant. Refer to Figure 13.3.

WARNING! Risk of Fire! DO NOT apply combustible materials beyond the minimum clearances. Comply with all minimum clearances to combustibles as specified in this manual. Overlapping materials could ignite and will interfere with proper operation of doors and louvers.

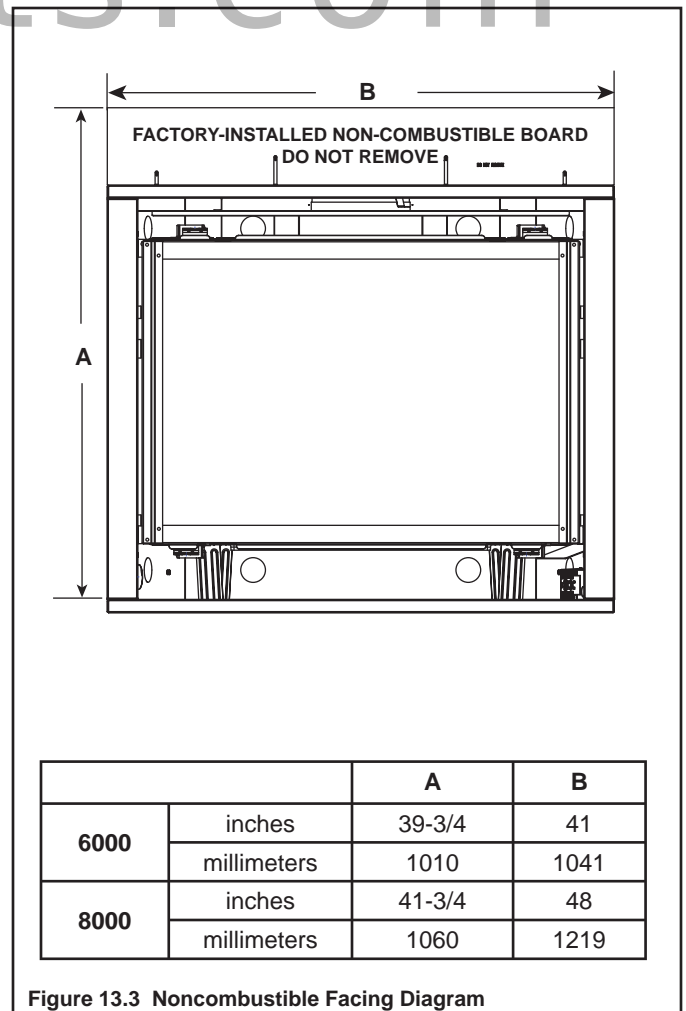

C. Doors

Only doors certified for use with this appliance model may be used. Contact your dealer for a list of doors that may be used. Once you have determined what kind of door and finishing material is going to be used on the fireplace, you may use the table below which shows the door models and the finishing material thickness allowed.

| DOOR | FIT | FINISH MATERIAL THICKNESS | SEE FIGURE |
|----------|---------|---------------------------|------------|
| Folio | Inside | Any | 13.6 |
| Arcadia | Overlap | 1 inch or less | 13.4 |
| | Inside | Greater than 1 inch | 13.5 |
| Halston | Overlap | 1 inch or less | 13.4 |
| | Inside | Greater than 1 inch | 13.5 |
| Chateau | Overlap | 1 inch or less | 13.4 |
| | Inside | Greater than 1 inch | 13.5 |
| Galleria | Overlap | 1 inch or less | 13.4 |
| | Inside | Greater than 1 inch | 13.5 |

Note: Finishing strips may be used to aid in positioning of non-combustible facing materials for some of the facing and door combinations specified in the table above. They must be removed following finishing work. See figure 13.7.

NOTICE: See service parts list (Section 16.B) for ordering finishing strips.

Finishing Material Thickness: 1 Inch Thick or Less

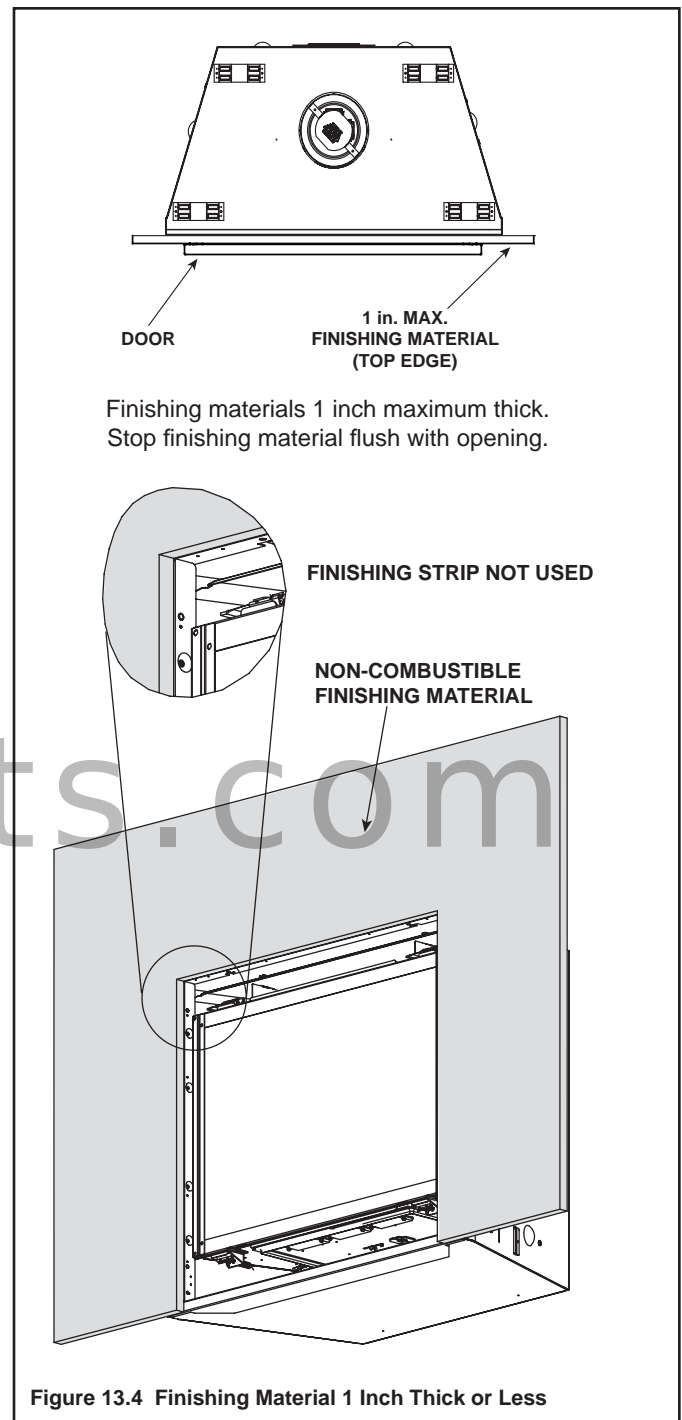

Finishing Material Thickness: Greater Than One Inch

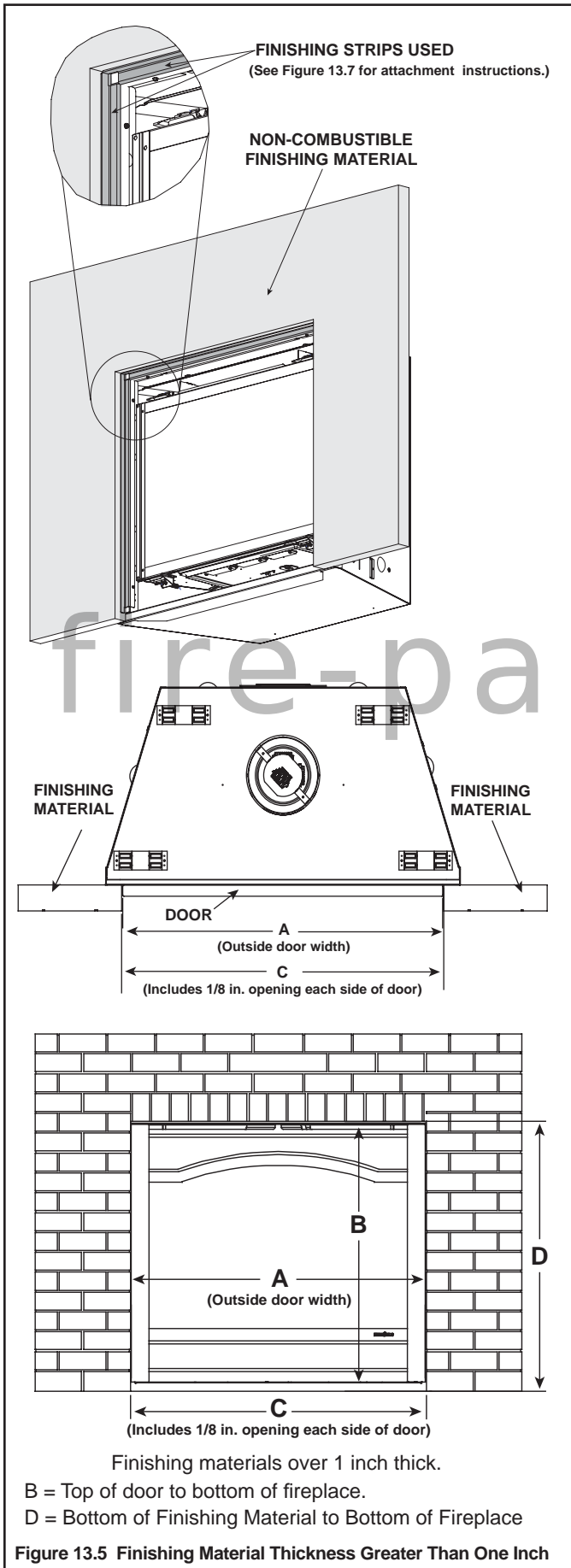

Figure 13.5 Finishing Material Thickness Greater Than One Inch

Finishing Material Thickness: Any

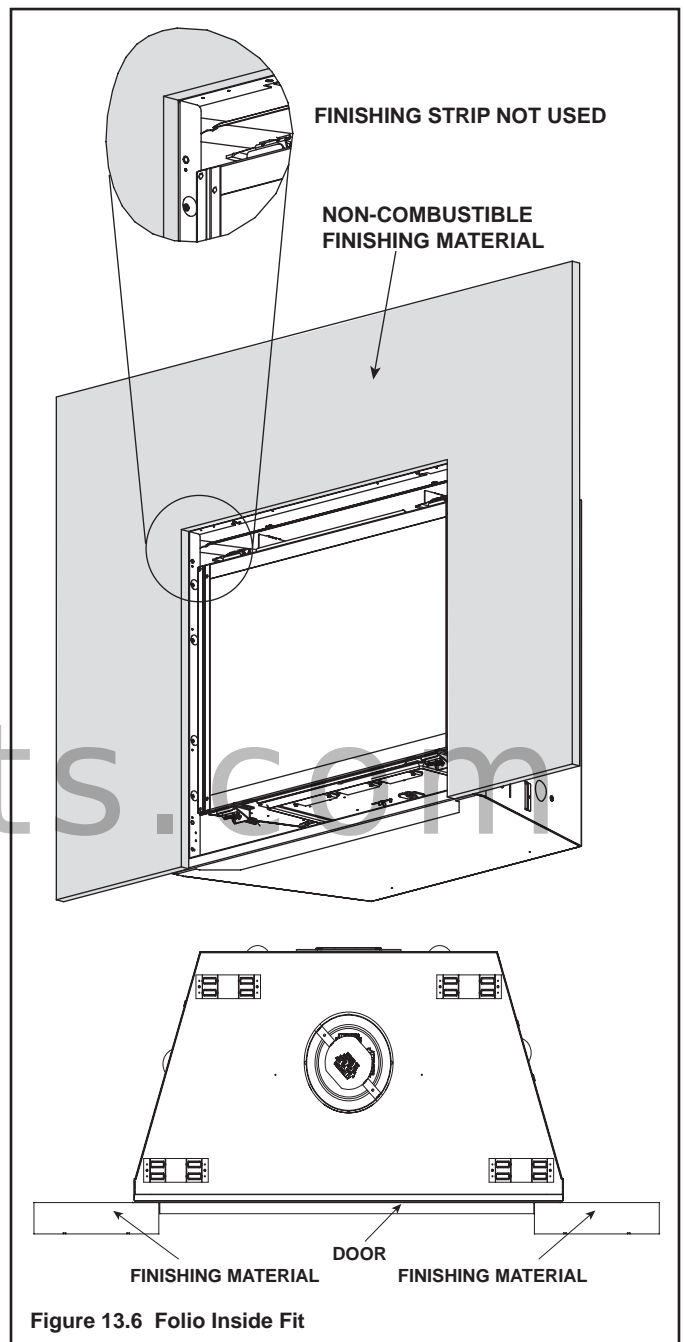
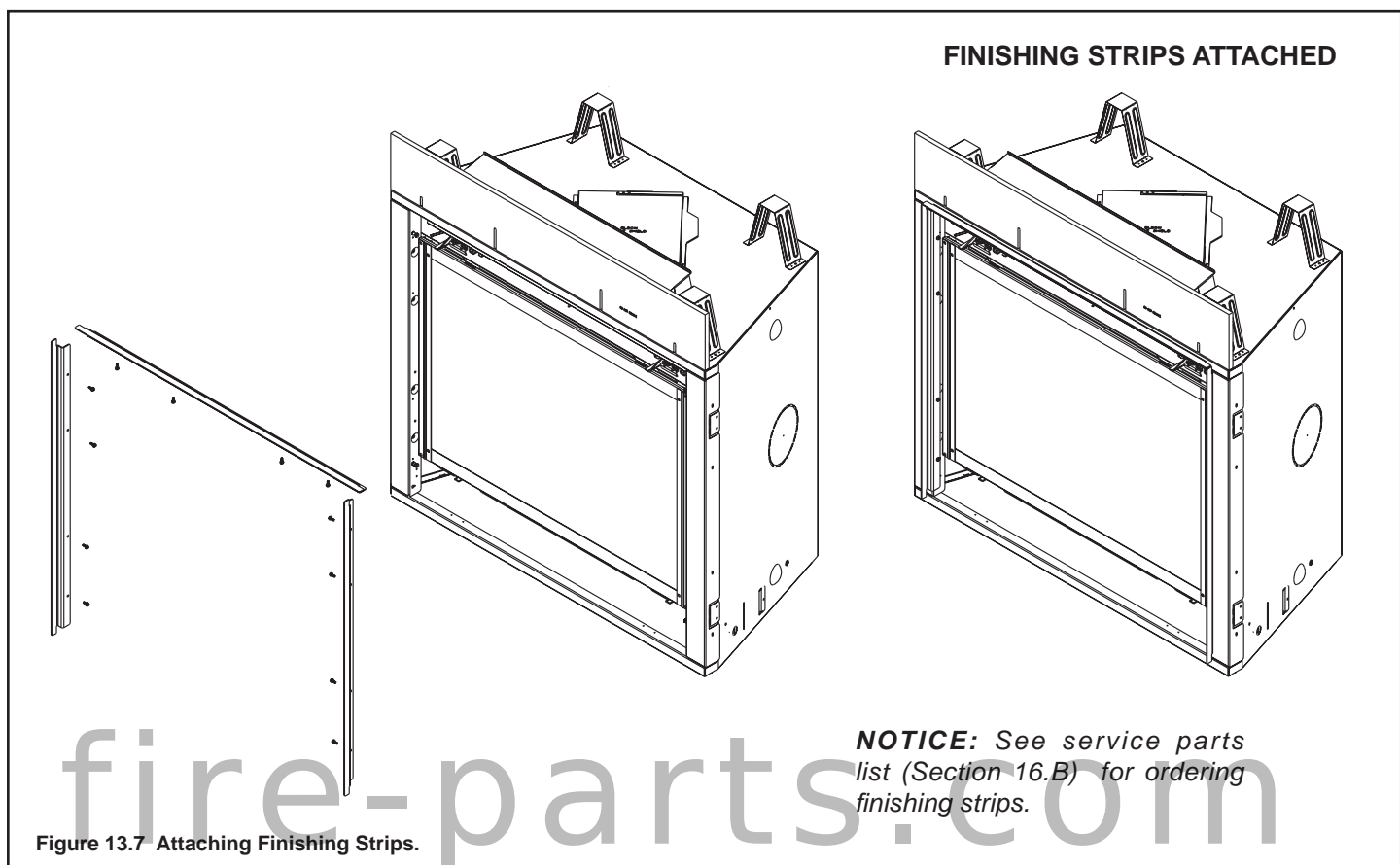

Figure 13.6 Folio Inside Fit

| | 8000 Models | | 6000 Models | |
|----------|-------------|-------------|-------------|-------------|
| | Inches | Millimeters | Inches | Millimeters |
| A | 44-1/16 | 1119 | 37-1/16 | 941 |
| B | 35-15/16 | 913 | 34-1/16 | 865 |
| C | 44-5/16 | 1126 | 37-5/16 | 948 |
| D | 36-5/16 | 922 | 34-7/16 | 882 |

Attachment of Finishing Strips



14 Appliance Setup

A. Remove Glass Assembly

See Section 14.H.

B. Remove the Shipping Materials

Remove shipping materials from inside or underneath the firebox.

C. Clean the Appliance

Clean/vacuum any sawdust that may have accumulated inside the firebox or underneath in the control cavity.

D. Accessories

Install approved accessories per instructions included with accessories. Contact your dealer for a list of approved accessories.

WARNING! Risk of Fire and Electric Shock! Use ONLY Hearth & Home Technologies-approved optional accessories with this appliance. Using non-listed accessories could result in a safety hazard and will void the warranty.

E. Burner Top Installation

1. Remove and retain the two screws holding the pilot cover in place.
2. To install the fiber burner, mate the locating holes with the guide sleeves. Install fiber burner top so that it makes full contact with the underlying burner assembly.
3. Reinstall the pilot cover using the two screws removed in step 1.
4. Ensure that the ports in the steel burner are visible through the holes in the fiber burner top.

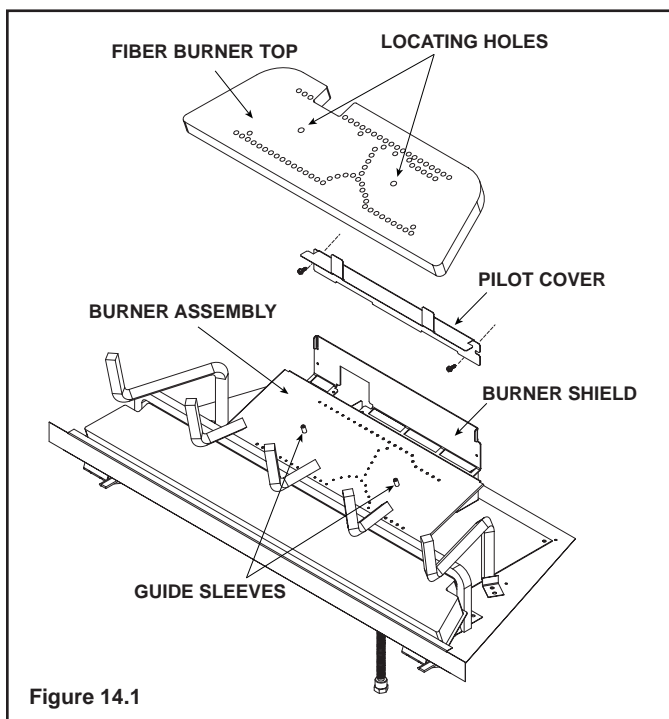

Figure 14.1

F. Ember Placement

WARNING! Risk of Explosion! Follow ember placement instructions in manual. DO NOT completely block burner ports with ember material. Replace ember material annually. Improperly placed embers interfere with proper burner operation.

Ember material is shipped with this gas appliance. To place the ember material:

- Embers CANNOT completely block burner ports. Care should be taken not to block the lighting trail of ports.
- Embers may only be placed in areas as shown in Figure 14.2.
- **LP Only:** Using dime-size pieces of Glowing Embers®, overlap the burner ports (see Figure 14.3). The impingement created by the embers will help blend the fire.
- Save the remaining ember materials for use during appliance servicing. The embers provided should be enough for 3 to 5 applications.

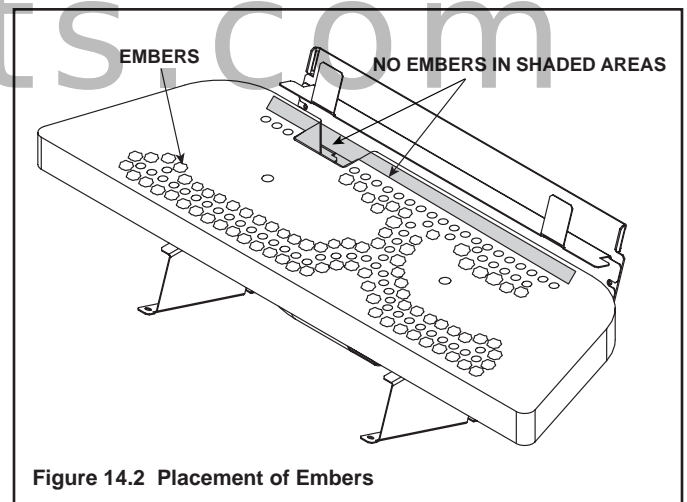

Figure 14.2 Placement of Embers

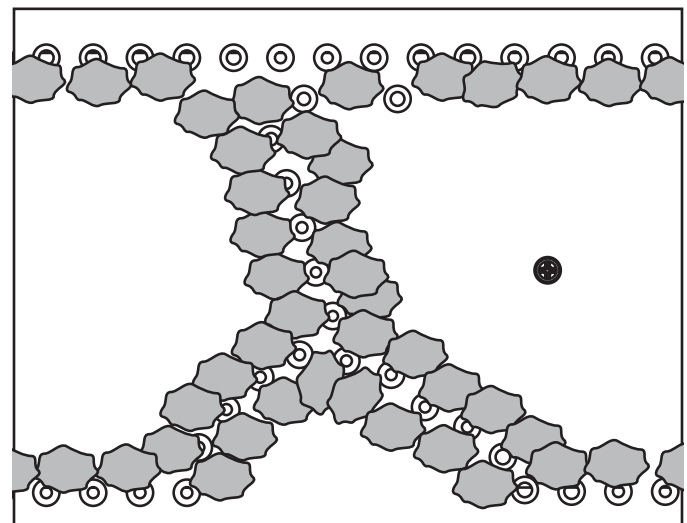

Figure 14.3 Embers Overlapping Burner Port Holes (LP only).

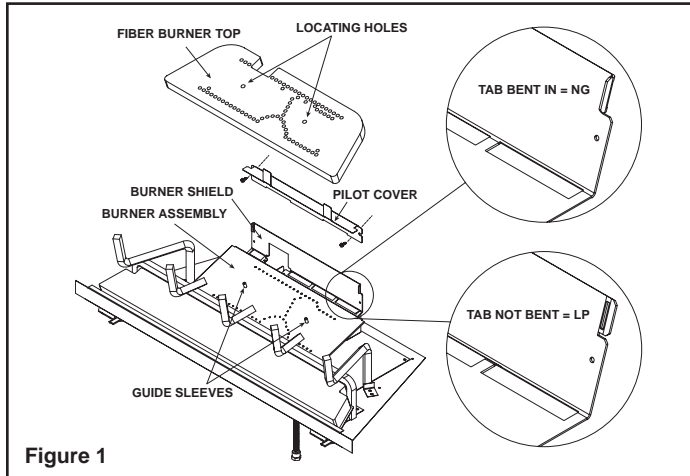

Figure 1

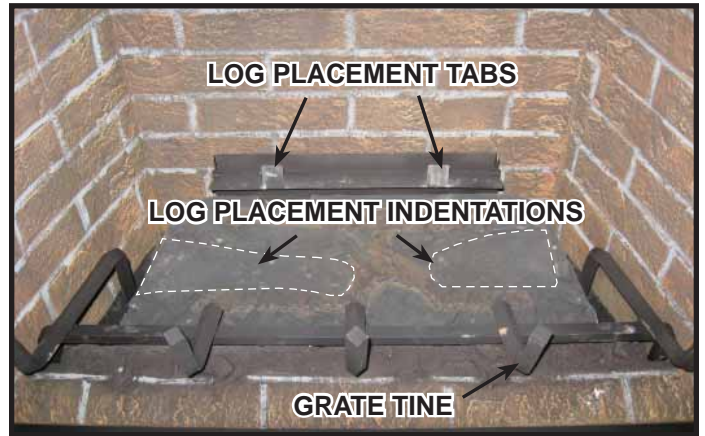

Figure 2. Firebox Shown with Optional Refractory

CAUTION: Logs are fragile, handle with care. **Log #1 (SRV2164-701):** Locate log placement tabs on the pilot cover (see Figure 2). Locate the log placements slots on the bottom of Log # 1 (see Figure 3). Mate the slots located on the bottom of Log #1 with the log placement tabs on the pilot cover. Log # 1 is properly installed when it sits squarely and completely on pilot cover with tabs engaged (see Figure 4).



Figure 3

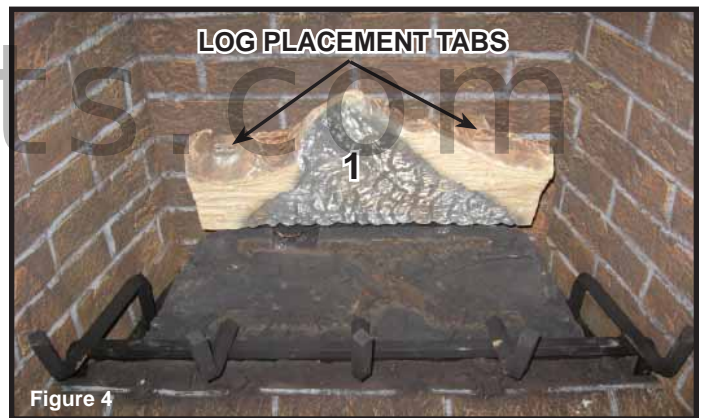

Figure 4

Figure 4 shows the log placement tabs located on the top of Log # 1. The tabs will be mated with the slots located on the bottom of Log #2 and Log #3 (see Figure 5). Log #2 and Log #3 also have grooves that allow the logs to be seated properly on the grate (see Figure 5). Hold Log #1 upright while placing Log #2.

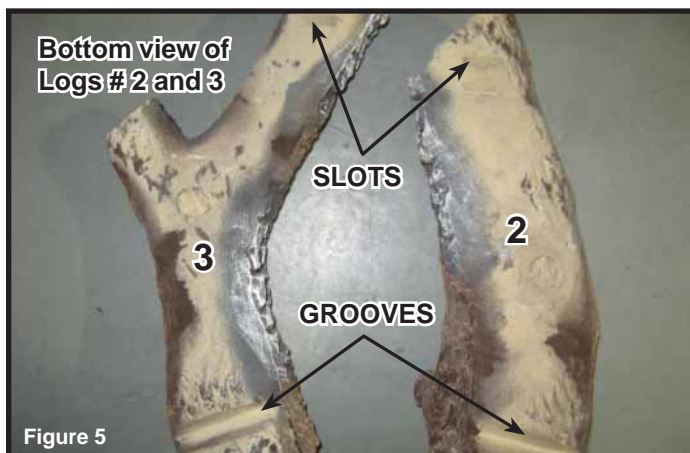

Figure 5

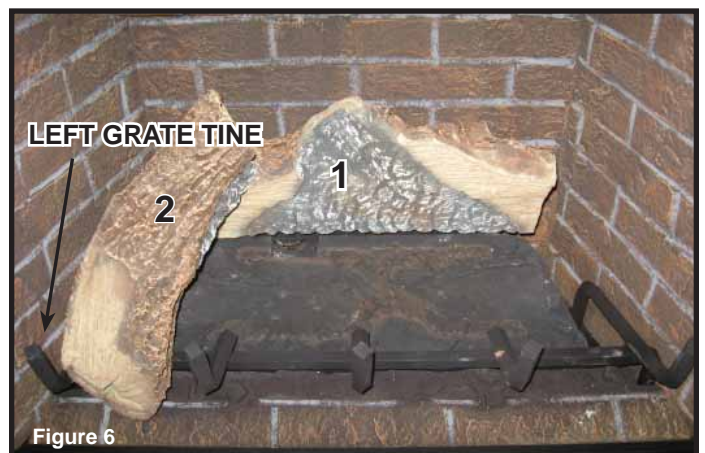
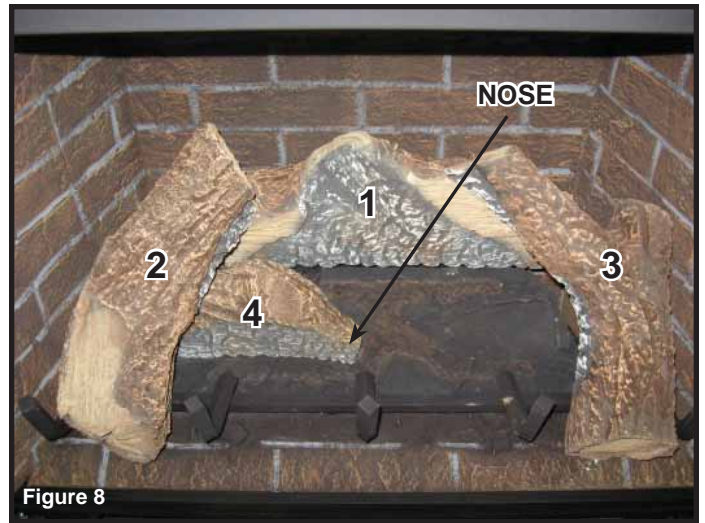
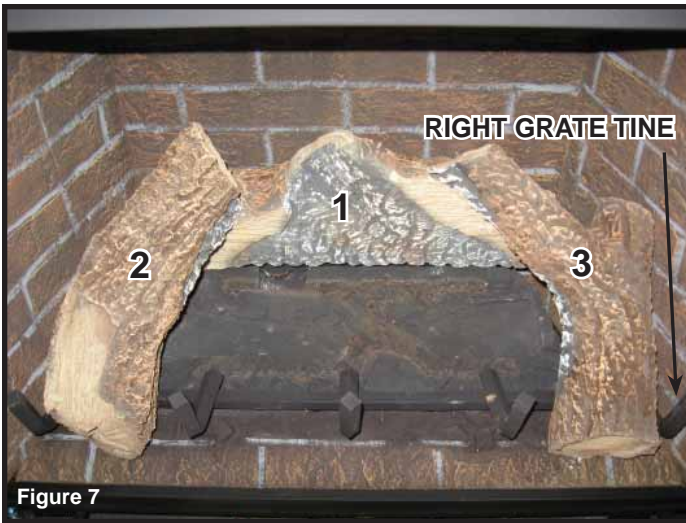

Figure 6

Log #2 (SRV2164-702): Mate the slot located on the bottom of Log #2 with the left tab on top of Log #1. After slot and tab have been fitted together, mate the groove located on the bottom of Log #2 with the horizontal grate bar and slide Log # 2 toward the left until it rests against the far left grate tine.



Log #3 (SRV2164-703): Mate the slot located on the bottom of Log #3 with the right log placement tab on top of Log #1. After slot and tab have been fitted together, mate the groove located on the bottom of Log #3 with the horizontal grate bar and slide Log # 3 toward the right until it rests against the far right grate tine (see Figure 7).

Log #4 (SRV2164-704): Place Log #4 in the left log indentation on the burner top (see Figure 2). Slide Log # 4 from right to left under Log #2 to fit completely and securely into the indentation (see Figure 8). Nose of log #4 should be pulled to fit securely against right hand side of log indentation.

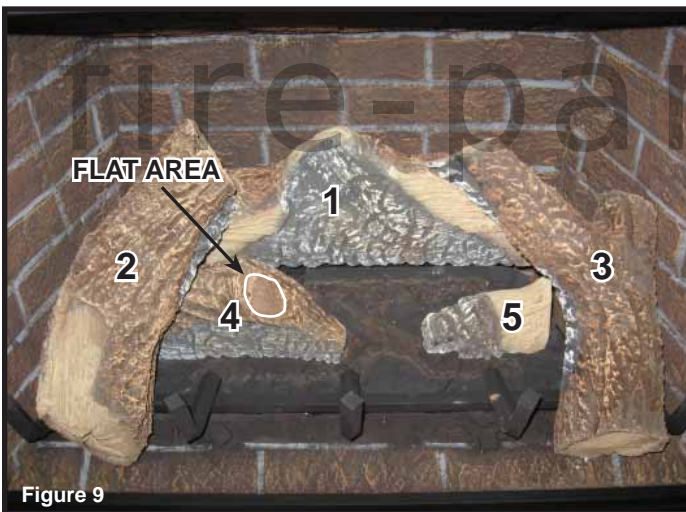

Log #5 (SRV2164-705): Place Log #5 in the right log indentation on the burner top (see Figure 2). Ensure the log fits completely and securely in the recessed indentation (see Figure 9). Log #5 should be pulled to the left hand side of log indentation.

Log #6 (SRV2164-706): Mate the groove located on the lower end of Log #6 with the fourth grate tine (from left to right) as shown in Figure 10. Set the other end of Log #6 on the flat area located on top of Log #4 (see Figure 9). Log #6 will also rest against center grate tine. When properly installed, Log #6 will rest securely on all 3 contact points, not allowing movement or shifting.

2164-935A

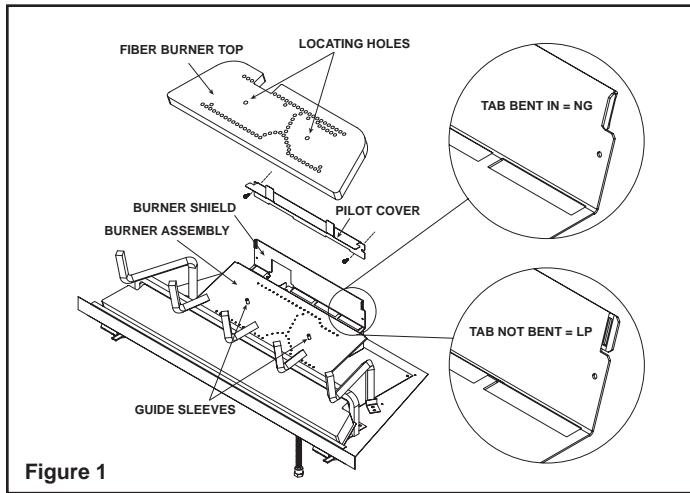

Figure 1



Figure 2. Firebox Shown with Optional Refractory

CAUTION: Logs are fragile, handle with care. **Log #1 (SRV2168-701):** Locate log placement tabs on the pilot cover (see Figure 2). Locate the log placements slots on the bottom of Log #1 (see Figure 3). Mate the slots located on the bottom of Log #1 with the log placement tabs on the pilot cover. Log #1 is properly installed when it sits squarely and completely on pilot cover with tabs engaged. See Figure 4.



Figure 3

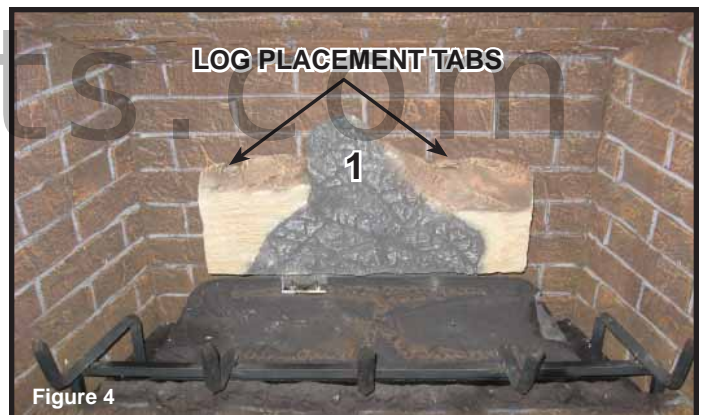

Figure 4

Figure 4 shows the log placement tabs located on the top of Log #1. The tabs will be mated with the slots located on the bottom of Log #2 and Log #3 (see Figure 5). Log #2 and Log #3 also have grooves that allow the logs to be seated properly on the grate (see Figure 5). Hold Log #1 upright while placing Log #2.

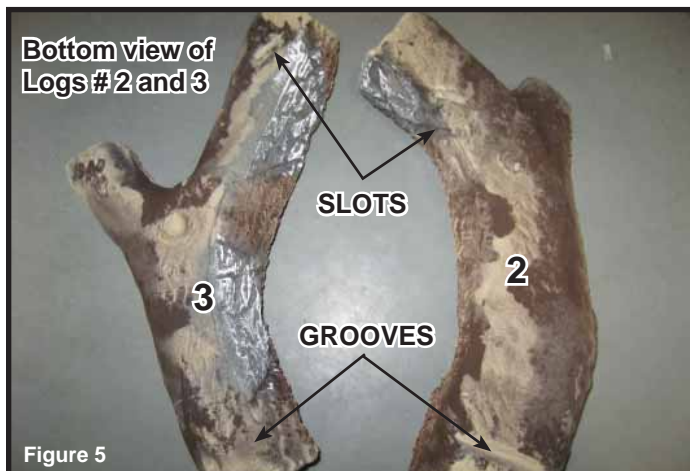
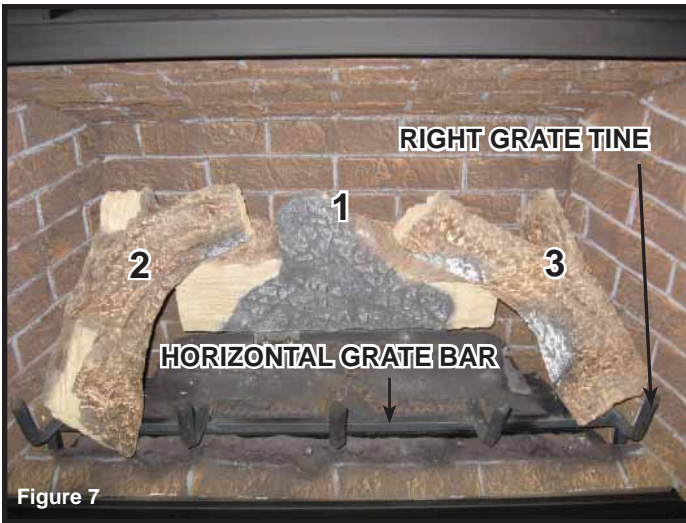

Figure 5



Figure 6

Log #2 (SRV2168-702): Mate the slot located on the bottom of Log #2 with the left log placement tab on top of Log #1. After slot and tab have been fitted together, mate the groove located on the bottom of Log #2 with the horizontal grate bar and slide Log #2 toward the left until it rests against the far left grate tine.



Log #3 (SRV2168-703): Mate the slot located on the bottom of Log #3 with the right log placement tab on top of Log #1. After slot and tab have been fitted together, mate the groove located on the bottom of Log #3 with the horizontal grate bar and far right grate tine. Log #3 will sit down on top of both the grate tine and the horizontal grate bar (see Figure 7).

Log #4 (SRV2168-704): Place Log #4 in the left log indentation on the burner top (see Figure 2). Slide Log #4 from right to left under Log #2 to fit completely and securely into the indentation (see Figure 8). The back or Log #4 should rest against the far left grate tine as well as contact Log #2.



Log #5 (SRV2168-705): Place Log #5 in the right log indentation on the burner top (see Figure 2). Ensure the log fits completely and securely in the indentation (see Figure 9). Log #5 should be pulled to the left hand side of log indentation.

Log #6 (SRV2168-706): Mate the groove located on the lower end of Log #6 with the fourth tine (from left to right) as shown in Figure 10. Set the other end of Log #6 on the flat area located on top of Log #4 (see Figure 9). Log #6 will also rest against center grate tine. When properly installed, Log #6 will rest securely on all 3 contact points, not allowing movement or shifting.

2168-935A

H. Fixed Glass Assembly

WARNING! Risk of Asphyxiation! Handle fixed glass assembly with care. Inspect the gasket to ensure it is undamaged and inspect the glass for cracks, chips or scratches.

- **DO NOT** strike, slam or scratch glass.
- **DO NOT** operate fireplace with glass removed, cracked, broken or scratched.
- Replace as a complete assembly.

Removing Fixed Glass Assembly

- Pull the four glass assembly latches out of the groove on the glass frame. Remove glass door from the appliance (see Figure 14.4).

Replacing Fixed Glass Assembly

- Replace the glass door on the appliance. Pull out and latch the four glass assembly latches into the groove on the glass frame.

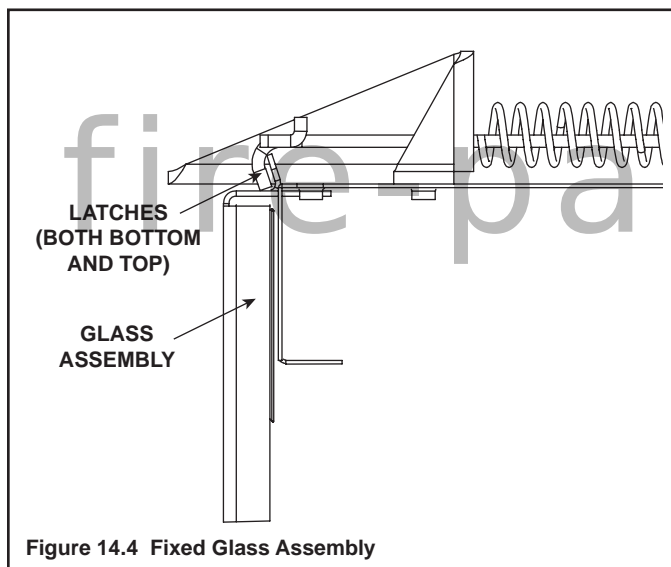

J. Air Shutter Setting

Air shutter settings should be adjusted by a qualified service technician at the time of installation. The air shutter is set at the factory for minimum vertical vent run. Adjust air shutter for longer vertical runs. See Figure 14.5.

- Loosen the wing nut.
- Move the air handle to the left to open the air shutter.
- Move the air handle to the right to close the air shutter.
- Tighten the wing nut.

NOTICE: If sooting occurs, provide more air by opening the air shutter.

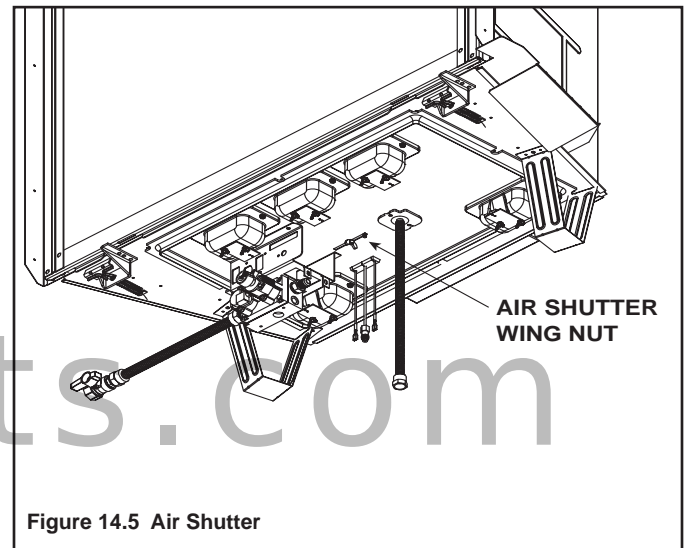

Air Shutter Settings

| | NG | LP |
|------|---------|---------|
| 6000 | 1/4 in. | 3/8 in. |
| 8000 | 1/4 in. | 3/8 in. |

I. Install Trim and/or Surround

- Install optional trim kits and/or surrounds using the instructions included with the accessory.
- Use non-combustible materials to cover the gap between the sheet rock and the appliance (when applicable to the model).

15 Troubleshooting

With proper installation, operation, and maintenance your gas appliance will provide years of trouble-free service. If you do experience a problem, this troubleshooting guide will assist a qualified service technician in the diagnosis of a problem and the corrective action to be taken. This troubleshooting guide can only be used by a qualified service technician. Contact your dealer to arrange a service call by a qualified service technician.

A. IntelliFire Plus™ Ignition System

| Symptom | Possible Cause | Corrective Action |
|--|---|---|
| 1. Pilot won't light. The ignitor/module makes noise, but no spark. | A. Incorrect wiring. | Verify "S" wire (white) for sensor and "I" wire (orange) for ignitor are connected to correct terminals on module and pilot assembly. |
| | B. Loose connections or electrical shorts in the wiring. | Verify no loose connections or electrical shorts in wiring from module to pilot assembly. Verify connections underneath pilot assembly are tight; also verify igniter and flame sense wires are not grounding out to metal chassis, pilot burner, pilot enclosure, mesh screen if present, or any other metal object. |
| | C. Ignitor gap is too large. | Verify gap of igniter to right side of pilot hood. The gap should be approximately .17 in. or 1/8 in. (3 mm). |
| 2. Pilot won't light, there is no noise or spark. | A. No power or transformer installed incorrectly. | Verify that transformer is installed and plugged into module. Check voltage of transformer at connection to module. Acceptable readings of a good transformer are between 6.4 and 6.6 volts AC. |
| | B. A shorted or loose connection in wiring configuration or wiring harness. | Remove and reinstall the wiring harness that plugs into module. Verify there is a tight fit. Verify pilot assembly wiring to module. Remove and verify continuity of each wire in wiring harness. Replace any damaged components. |
| | C. Improper wall switch wiring. | Verify that 110/VAC power is "ON" to junction box. |
| | D. Module not grounded. | Verify black ground wire from module wire harness is grounded to metal chassis of appliance. |
| 3. Pilot sparks, but Pilot will not light. | A. Gas supply. | Verify that incoming gas line ball valve is "open". Verify that inlet pressure reading is within acceptable limits. |
| | B. Ignitor gap is too large. | Verify gap of igniter to right side of pilot hood. The gap should be approximately .17 in. or 1/8 in. (3 mm). |
| | C. Module is not grounded. | Verify module is securely grounded to metal chassis of appliance. |
| | D. Pilot valve solenoid | Verify that 1.5 to 1.8 VDC is supplied to pilot solenoid from module. If below 1.5 volts, replace module. If 1.5 volts or greater, replace valve. |

IntelliFire Plus™ Ignition System - (continued)

| Symptom | Possible Cause | Corrective Action |
|--|--|--|
| 4. Pilot lights but continues to spark, and main burner will not ignite. (If the pilot continues to spark after the pilot flame has been lit, flame rectification has not occurred.) | A. A shorted or loose connection in flame sensing rod. | Verify all connections to wiring diagram in manual. Verify connections underneath pilot assembly are tight. Verify flame sense or igniter wires are not grounding out to metal chassis, pilot burner, pilot enclosure or screen if present, or any other metal object. |
| | B. Poor flame rectification or contaminated flame sensing rod. | With fixed glass assembly in place, verify that flame is engulfing flame sensing rod on left side of pilot hood. Flame sensing rod should glow shortly after ignition. With a multimeter, verify that current in series between module and sense lead is at least 0.14 microamps. Verify correct pilot orifice is installed and gas inlet is set to pressure specifications. Clean flame sensing rod with emery cloth to remove any contaminants that may have accumulated on flame sensing rod. |
| | C. Module is not grounded. | Verify module is securely grounded to metal chassis of appliance. Verify that wire harness is firmly connected to the module. |
| | D. Damaged pilot assembly or contaminated flame sensing rod. | Verify that ceramic insulator around the flame sensing rod is not cracked, damaged, or loose. Verify connection from flame sensing rod to white sensor wire. Clean flame sensing rod with emery cloth to remove any contaminants that may have accumulated on flame sensing rod. Verify continuity with a multimeter with ohms set at lowest range. Replace pilot if any damage is detected. |

fire-parts.com

16 Reference Materials

A. Appliance Dimension Diagram

Dimensions are actual appliance dimensions. Use for reference only. For framing dimensions and clearances refer to Section 5.

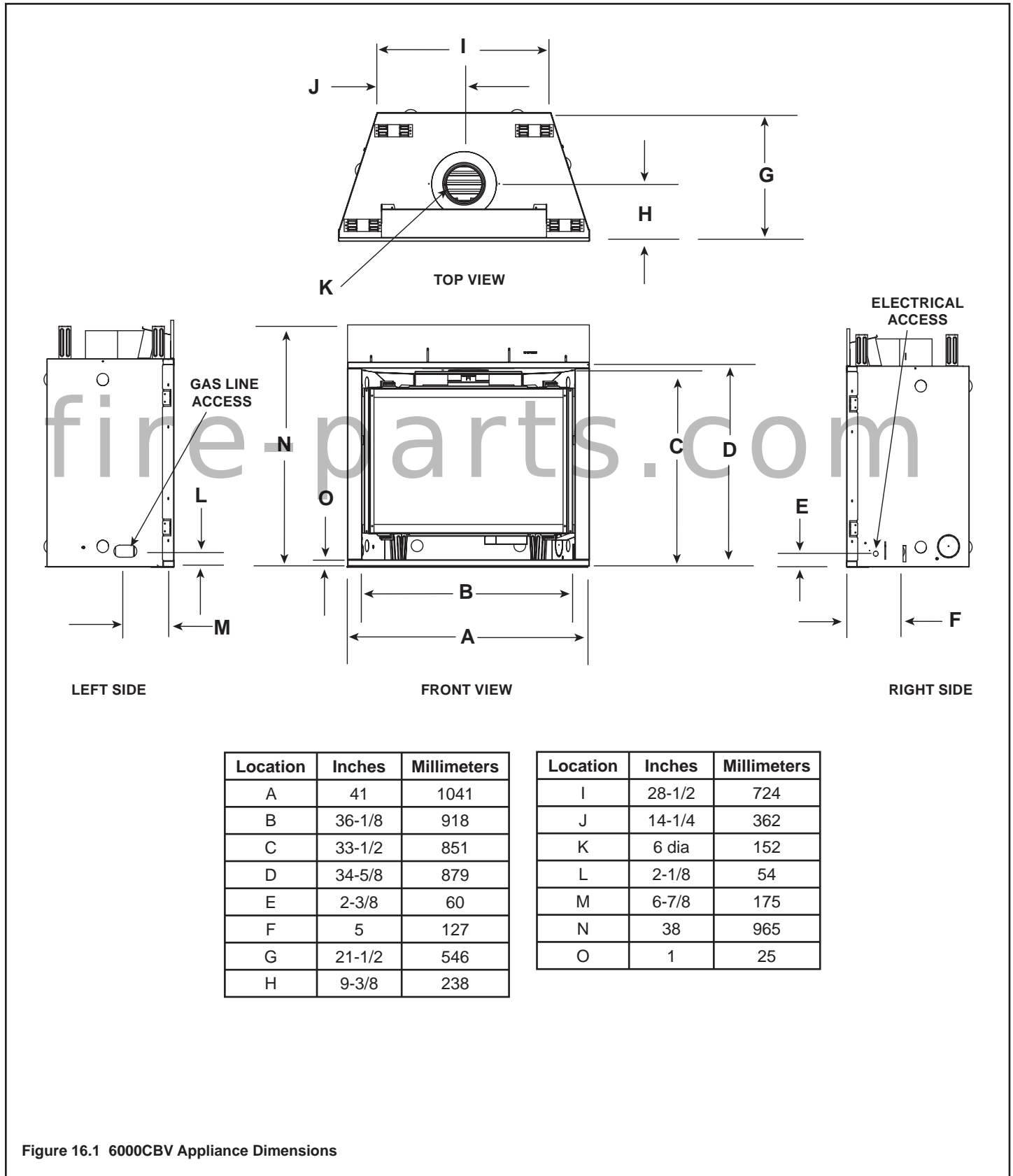
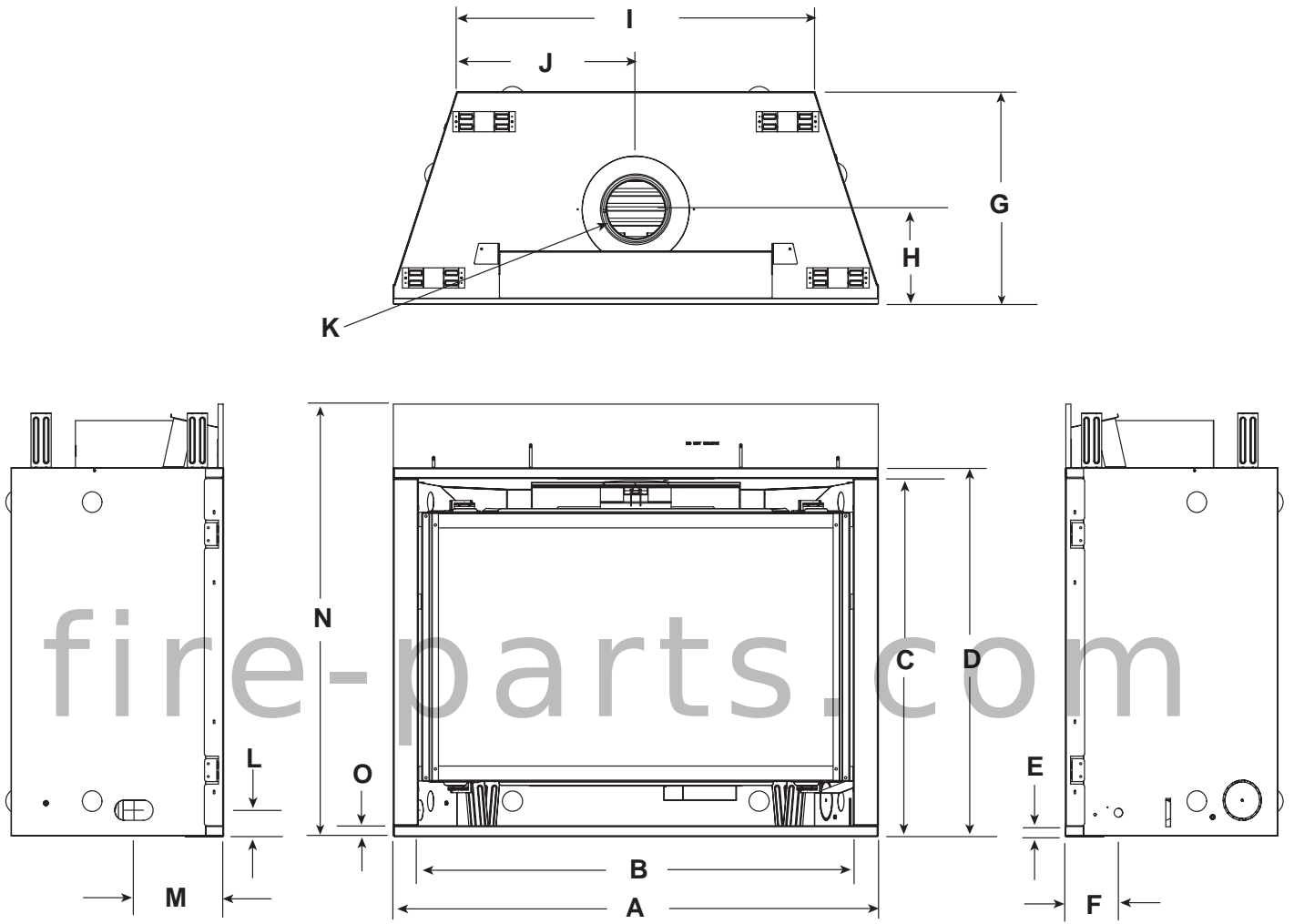

Figure 16.1 6000CBV Appliance Dimensions



| Location | Inches | Millimeters |
|----------|---------|-------------|
| A | 48 | 1219 |
| B | 43 | 1092 |
| C | 35-1/2 | 902 |
| D | 36-9/16 | 929 |
| E | 2-3/8 | 60 |
| F | 5-1/4 | 133 |
| G | 21-1/16 | 535 |
| H | 9-1/2 | 241 |

| Location | Inches | Millimeters |
|----------|--------|-------------|
| I | 35-1/2 | 902 |
| J | 17-3/4 | 451 |
| K | 6 | 152 |
| L | 2-5/8 | 143 |
| M | 8-7/8 | 225 |
| N | 42-7/8 | 1089 |
| O | 1 | 25 |

Figure 16.2 8000CBV Appliance Dimensions

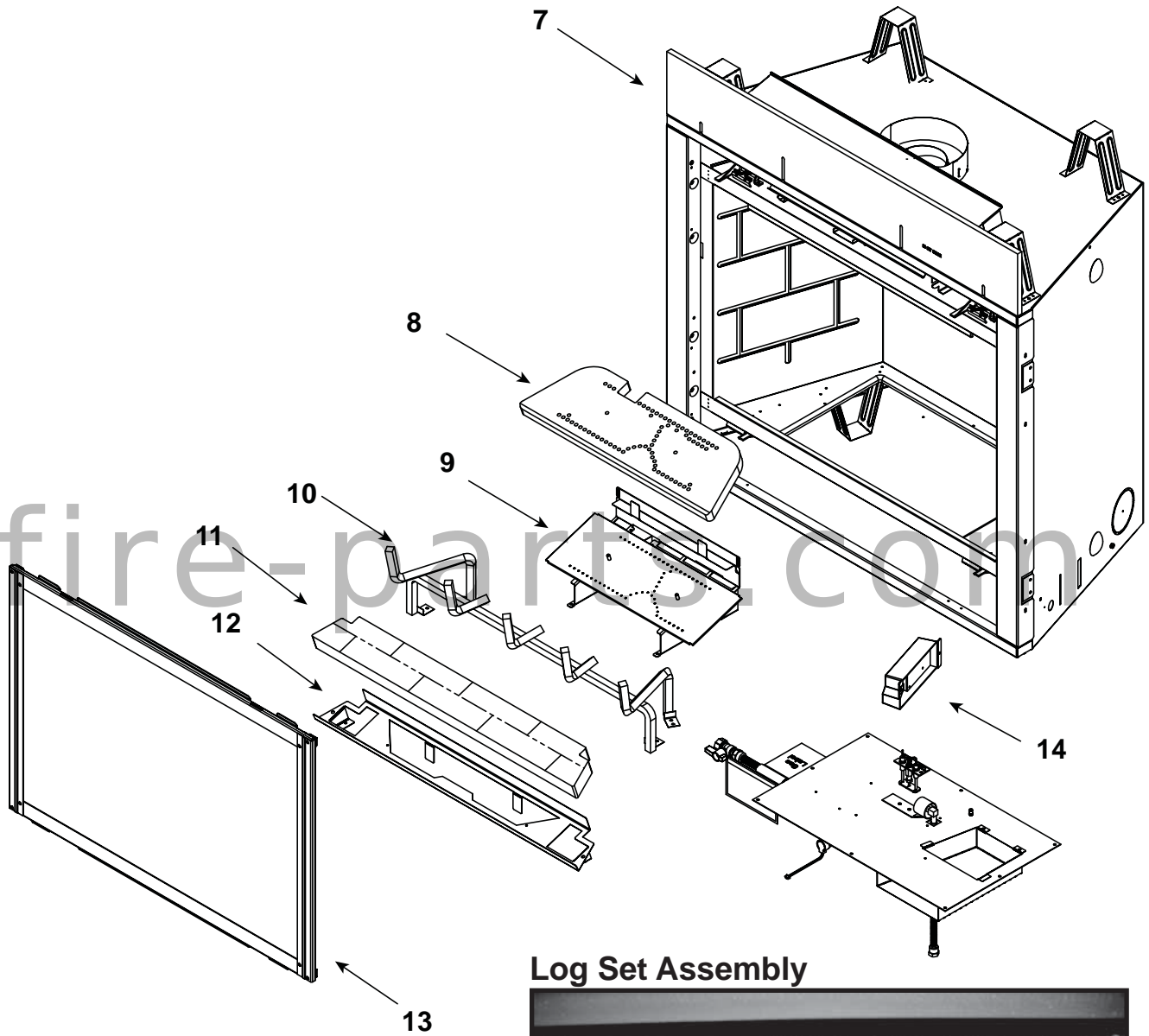

Log Set Assembly

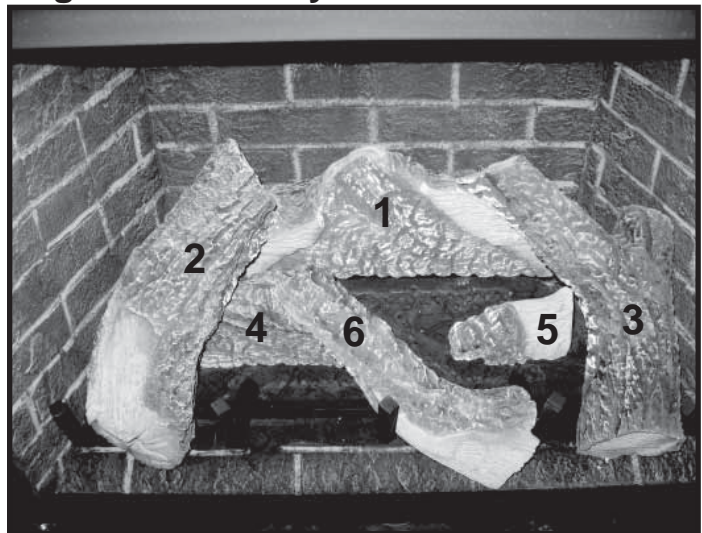

Part number list on following page.

Service Parts List

6000CBV-IPI

IMPORTANT: THIS IS DATED INFORMATION. When requesting service or replacement parts for your appliance please provide model number and serial number. All parts listed in this manual may be ordered from an authorized dealer.



**Stocked
at Depot**

| ITEM | DESCRIPTION | COMMENTS | PART NUMBER | Stocked at Depot |
|------|---------------------------------|-------------------------|----------------|------------------|
| | Log Set Assembly | | LOGS-6C | Y |
| 1 | Log 1 | | SRV2164-701 | |
| 2 | Log 2 | | SRV2164-702 | |
| 3 | Log 3 | | SRV2164-703 | |
| 4 | Log 4 | | SRV2164-704 | |
| 5 | Log 5 | | SRV2164-705 | |
| 6 | Log 6 | | SRV2164-706 | |
| 7 | Insulation Board | | 2166-136 | |
| 8 | Burner Top | | SRV2166-100 | Y |
| 9 | Burner NG | | 2164-007 | Y |
| | Burner LP | | 2164-008 | Y |
| 10 | Log Grate | | 2166-104 | |
| 11 | Base Refractory | | SRV6BASE-STRAT | |
| 12 | Refractory Basket | | 2166-108 | |
| 13 | Glass Door Assembly | | GLA-6000G | Y |
| 14 | Junction Box | | 4021-013 | Y |
| | Finishing Strips | Sold as Kit only | SRVFS-6 | |
| | Glass Latch Support | Qty 4 req | 386-122A | Y |
| | High Limit Switch | | 066-531 | Y |
| | High Limit Switch Wire Assembly | | 2167-353 | Y |
| | Mineral Wool | | 050-721 | |
| | Surround Assembly | | 2166-019 | |
| | Touch Up Paint | | TUP-GBK-12 | |
| | | | | |
| | | | | |
| | | | | |
| | | | | |
| | | | | |
| | | | | |
| | | | | |
| | Conversion Kit NG | | N/A | |
| | Conversion Kit LP | | LPKI-6CBV | Y |
| | Regulator NG | | NGK-DXV-50 | Y |
| | Regulator LP | | LPK-DXV-50 | Y |
| | Pilot Orifice NG | | 593-528 | Y |
| | Pilot Orifice LP | | 593-527 | Y |

Additional service part numbers appear on following page.

IMPORTANT: THIS IS DATED INFORMATION. When requesting service or replacement parts for your appliance please provide model number and serial number. All parts listed in this manual may be ordered from an authorized dealer.



**Stocked
at Depot**

| ITEM | DESCRIPTION | COMMENTS | PART NUMBER | |
|------|----------------------------|-------------------------|----------------|---|
| | Log Set Assembly | | LOGS-8C | Y |
| 1 | Log 1 | | SRV2168-701 | |
| 2 | Log 2 | | SRV2168-702 | |
| 3 | Log 3 | | SRV2168-703 | |
| 4 | Log 4 | | SRV2168-704 | |
| 5 | Log 5 | | SRV2168-705 | |
| 6 | Log 6 | | SRV2168-706 | |
| 7 | Insulation Board | | 2170-136 | |
| 8 | Burner Top | | SRV2170-100 | Y |
| 9 | Burner NG | | 2168-007 | Y |
| | Burner LP | | 2168-008 | Y |
| 10 | Log Grate | | 2170-104 | |
| 11 | Base Refractory | | SRV8BASE-STRAT | |
| → 12 | Refractory Basket | | 2170-108 | |
| 13 | Glass Door Assembly | | GLA-950TR | Y |
| 14 | Junction Box | | 4021-013 | Y |
| | | | | |
| | Finishing Strips | Sold as kit only | SRVFS-8 | |
| | Glass Latch Support | Qty 4 req | 386-122A | Y |
| | High Limit Switch | | 066-531 | Y |
| | High Limit Switch Assembly | | 2167-353 | Y |
| | Mineral Wool | | 050-721 | |
| | Surround Assembly | | 2170-019 | |
| | Touch Up Paint | | TUP-GBK-12 | |
| | | | | |
| | | | | |
| | | | | |
| | | | | |
| | | | | |
| | | | | |
| | Conversion Kit NG | | N/A | |
| | Conversion Kit LP | | LPKI-8CBV | Y |
| | Regulator NG | | NGK-DXV-50 | Y |
| | Regulator LP | | LPK-DXV-50 | Y |
| | Pilot Orifice NG | | 593-528 | Y |
| | Pilot Orifice LP | | 593-527 | Y |

Additional service part numbers appear on following page.

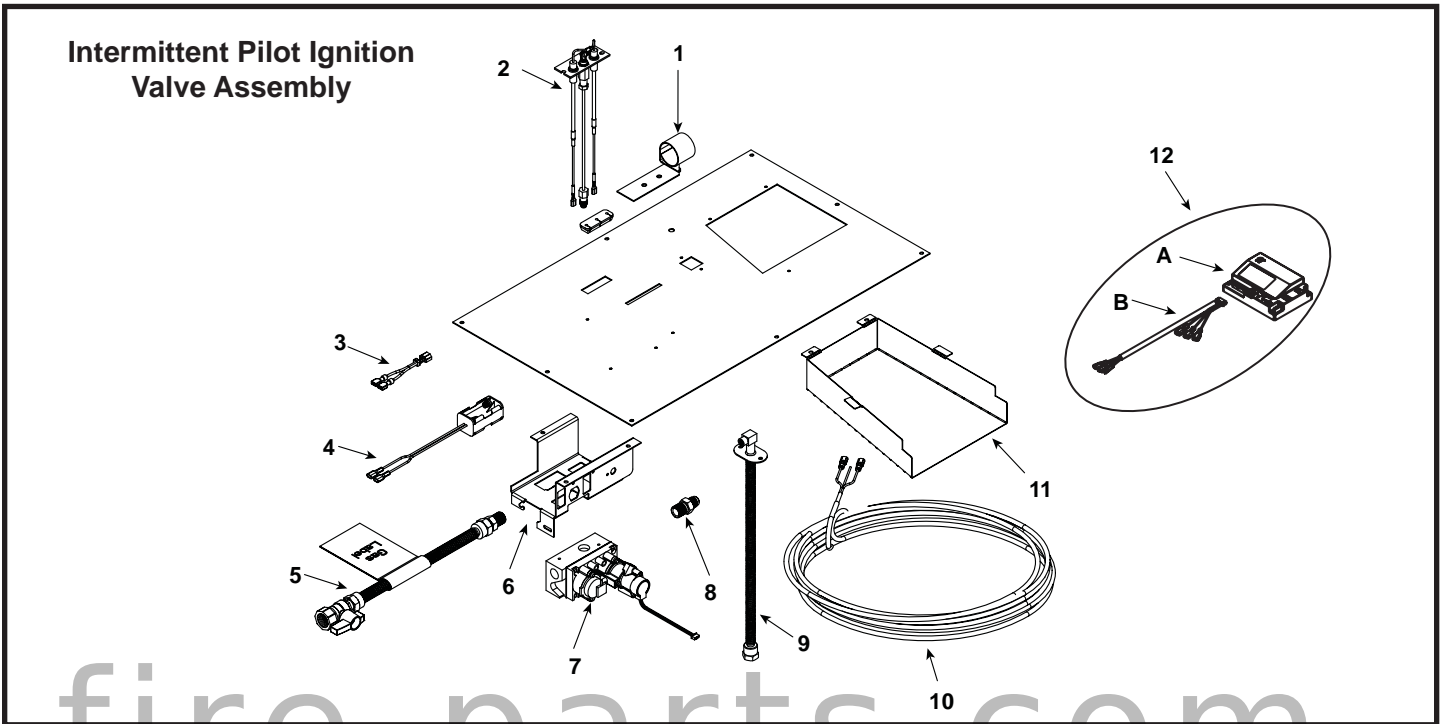

IMPORTANT: THIS IS DATED INFORMATION. When requesting service or replacement parts for your appliance please provide model number and serial number. All parts listed in this manual may be ordered from an authorized dealer.



Stocked at Depot

| ITEM | DESCRIPTION | COMMENTS | PART NUMBER | Stocked at Depot |
|------|--------------------------|-------------|-------------|------------------|
| 1 | Shutter Bracket Assembly | | 2166-157 | Y |
| 2 | Pilot Assembly NG | | 2166-370 | Y |
| | Pilot Assembly LP | | 2166-371 | Y |
| | Pilot Tube | | SRV485-301 | Y |
| 3 | Jumper Wire | | 2187-198 | Y |
| 4 | Battery Pack | | 2166-323 | Y |
| 5 | Flex Ball Valve Assembly | | 302-320A | Y |
| 6 | Valve Bracket | | 2118-104 | |
| 7 | Valve NG | | 2166-302 | Y |
| | Valve LP | | 2166-303 | Y |
| 8 | Male Connector | | 303-315/5 | Y |
| 9 | Bulkhead W/Tube | | 2166-119 | Y |
| 10 | Wire Assembly | | 2045-024 | |
| 11 | Chute | | 2167-182 | |
| 12 | Control Assembly | | 2164-030 | Y |
| A | Module | | 2166-307 | |
| B | Wire Harness | | 2166-304 | |
| | Burner Orifice NG (#39C) | 6000CBV-IPI | 582-839 | Y |
| | Burner Orifice LP (#52C) | | 582-852 | Y |
| | Burner Orifice NG (#34C) | 8000CBV-IPI | 582-834 | Y |
| | Burner Orifice LP (#51C) | | 582-851 | Y |

C. Contact Information



No one builds a better fire

Heat & Glo, a brand of Hearth & Home Technologies Inc.
7571 215th Street West, Lakeville, MN 55044
www.heatnglo.com

Please contact your Heat & Glo dealer with any questions or concerns.
For the location of your nearest Heat & Glo dealer,
please visit www.heatnglo.com.

- NOTES -

fire-parts.com

NOTICE



- Important operating and maintenance instructions included.

DO NOT DISCARD THIS MANUAL

- Read, understand and follow these instructions for safe installation and operation.

- Leave this manual with party responsible for use and operation.



This product may be covered by one or more of the following patents: (United States) 4593510, 4686807, 4766876, 4793322, 4811534, 5000162, 5016609, 5076254, 5113843, 5191877, 5218953, 5263471, 5328356, 5341794, 5347983, 5429495, 5452708, 5542407, 5601073, 5613487, 5647340, 5688568, 5762062, 5775408, 5890485, 5931661, 5941237, 5947112, 5996575, 6006743, 6019099, 6048195, 6053165, 6145502, 6170481, 6237588, 6296474, 6374822, 6413079, 6439226, 6484712, 6543698, 6550687, 6601579, 6672860, 6688302B2, 6715724B2, 6729551, 6736133, 6748940, 6748942, 6769426, 6774802, 6796302, 6840261, 6848441, 6863064, 6866205, 6869278, 6875012, 6880275, 6908039, 6919884, D320652, D445174, D462436; (Canada) 1297749, 2195264, 2225408, 2313972; (Australia) 780250, 780403, 1418504 or other U.S. and foreign patents pending.

Printed in U.S.A. - Copyright 2009