

# Installation Instructions

Listed Certified for USA. and Canada

Certified to: ANSI Z21.44a-1992/CAN 1-2. 19-M81/CGA I.R.#55/CAN/CGA 2.17-1991,CR89-001,  
ANSI Z21.50-1996/CGA 2.22-M96, UL307B-1995, CGA P.4.1-1996

**Model Number FDV5000**



## “Free Standing” Direct Vent Gas Stove

**Read this complete manual before beginning installation.  
These instructions must be kept with the unit for future reference.**

### **FOR YOUR SAFETY**

**Warning:** Improper installation, alteration, service or maintenance can cause property damage, personal injury or loss of life. Refer to this manual. Installation and service must be performed by a qualified installer, service agency or the gas supplier.

Do not store or use gasoline or other flammable vapors and liquids in the vicinity of this or any other appliance.

#### **What To Do If You Smell Gas**

Do not try to light any appliance.

Extinguish any open flame.

Do not touch any electrical switch.

Do not use any phone in your building.

Immediately call your gas supplier from a neighbour's phone.

If you can not reach your gas supplier, call the fire department.



### **KINGSMAN INDUSTRIES**

A Division of R-Co. Inc.

2340 Logan Ave., Winnipeg, Manitoba, Canada R2R 2V3

Ph: (204) 632-1962

### Why does my fireplace or stove give off odour?

It is normal for your fireplace to give off some odour. This is due to the curing of the paint, adhesives, silicones and any undetected oil from the manufacturing process as well as the finishing materials used with the installations (e.g. marble, tile and the adhesives used to adhere this product to the walls can react with heat and cause odours).

It is recommended that you burn your gas fireplace or stove for a minimum of four hours at a time with the fan off after the curing of the paint has been completed. These odours can last upward to 40 hours of burn time, keep burning at a minimum of four hours per use until odours dissipate.

### About curing of the paint

Your stove or fireplace has been painted with the highest quality silicone stove paint. This paint dries quickly in 15-20 minutes when first applied at the factory. However, due to the high temperature silicone components, the paint will cure when heat is applied to the appliance as it is first used.

The following information **applies to the curing process** to get the paint fully hard and durable.

Fire the appliance four successive times for 10 minutes each firing and a 5 minute cool down between each. Be aware during log and firebox paint curing that a white deposit may be developing on the inside of the glass doors. It is important to remove this white deposit from the glass doors with an appropriate cleaner to prevent build-up (such as Windex or a commercial fireplace glass cleaner).

- Babies, small children, pregnant women and pets should leave the area during the cure phase.
- Ventilate well, open doors and windows.
- Do not touch during curing.

### Noise coming from the fireplace?

- Noise caused by metal expanding and contracting as it heats up and cools down, similar to the sound produced by a furnace or heating duct. This noise does not affect the operation or longevity of your fireplace.

## Table of Contents

Mobile home/manufactured housing installation .....	4
Installation and operation .....	5
Locating your appliance .....	6
Gas line installation .....	7
Gas specifications .....	8
Operating and maintenance instructions .....	8
General glass information .....	9
Log assembly .....	10
Log Placement .....	11-12
Optional fan kit installation .....	13
Millivolt system, lighting, & burner control .....	15
Vent termination .....	16
General venting information .....	17
Vent pipe assembly .....	19
Horizontal vent installation .....	19
Vertical vent installation .....	21
Venting kits and components .....	22
Accessory list .....	22
Replacement parts list .....	23
Trouble shooting the gas control system .....	24
Warranty .....	25

## MOBILE HOME/MANUFACTURED HOUSING INSTALLATION

This Direct Vent System Appliance must be installed in accordance with the manufacturer's installation instructions and the Manufactured Home Construction and Safety Standard Title 24 CFR, Part 3280, or the current Standard for Fire Safety Criteria for Manufactured Home Installations, Sites, and Communities ANSI/NFPA 501A, and with CAN/CSA Z240 Mobile Home Standard in Canada.

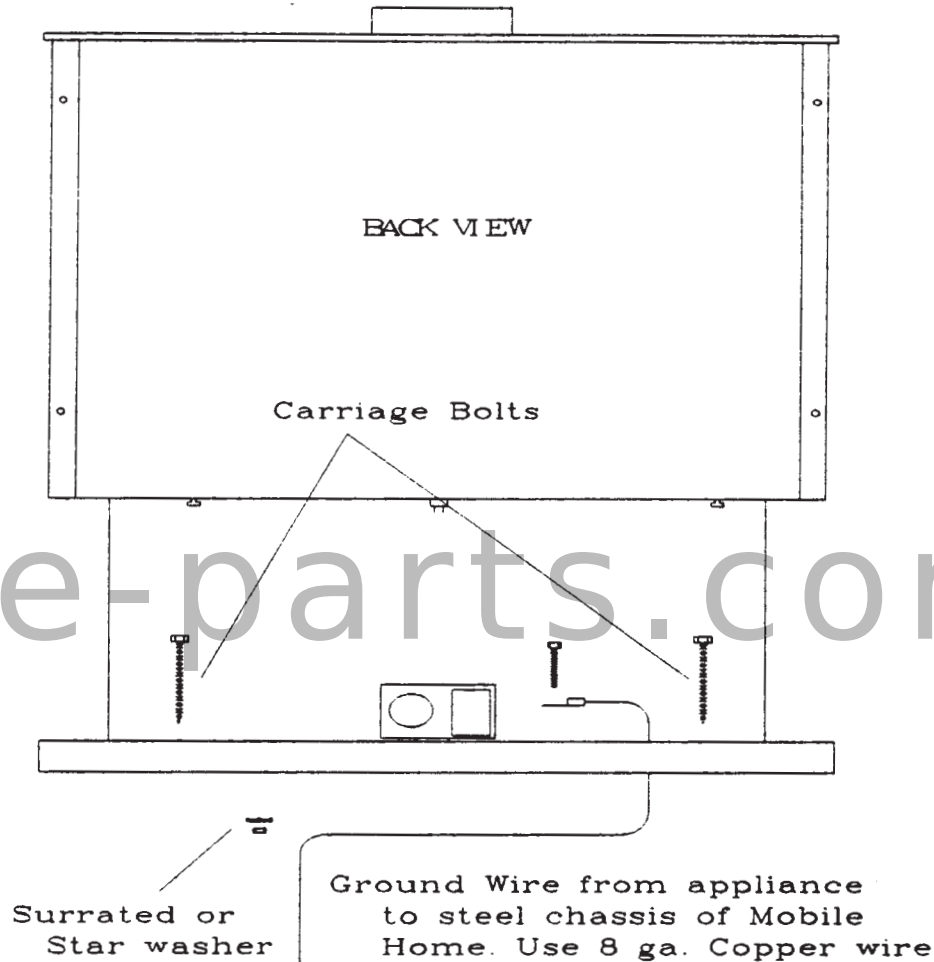

THIS APPLIANCE MAY BE INSTALLED IN MANUFACTURED (MOBILE) HOMES AFTER FIRST SALE.

Please follow the current ANSI/NFPA 70 National Electrical Code in the USA and CAN/CSA C22.1 Canadian National Electrical Code in Canada.

Appliance must be grounded to the steel chassis of the home with 8 ga. copper wire using a serrated or star washer to penetrate paint or protective coating to insure grounding.

Use carriage bolt at the attachment point (see diagram above) to secure the appliance to the floor.

**Warning:** Do not compromise the structural integrity of the manufactured home wall, floor or ceiling, during installation of appliance or venting.

*For required venting components see venting installation in appropriate section of this manual.*

# INSTALLATION AND OPERATION

A	27 3/4"
B	22 3/4"
C	17"
D	23 3/4"
E	19"
F	4"
G	6 1/4"
H	7"

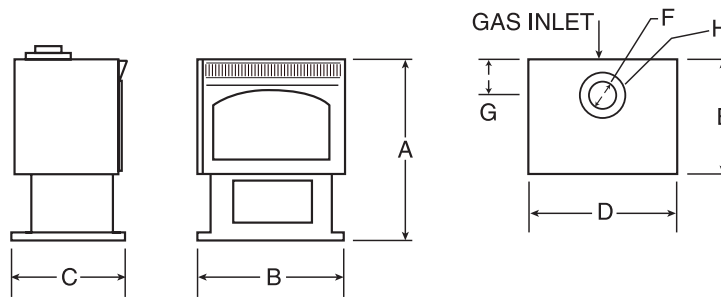

Gas inlet is located on the back of the unit.

## **INSTALLATION REGULATIONS**

This gas appliance must be installed by a qualified installer in accordance with local building codes, or in the absence of local codes, with the current CANCGA-B149.1 or .2 Installation Code (in Canada) or the current National Fuel Gas Code Z223.1 when installed in the United States.

This appliance, when installed, must be electrically connected and grounded in accordance with local codes, with the current CSA C22.2 Canadian Electrical Code or with the national Electrical Code; ANSI/NFPA 70-1987 when installed in the United States.

This unit is certified for installation in a bedroom or bed sitting room, the unit must be installed with listed thermostat.

**IN CANADA** these units are acceptable for mobile homes (manufactured) home installations **after first sale**. Though it would be very beneficial to also check with your local building codes, in respect to each province, or jurisdiction. **IN THE USA THIS UNIT IS CERTIFIED TO 307B ACCEPTABLE FOR MOBILE HOMES(MANUFACTURED) HOME INSTALLATIONS.**

Efficiency rating of the appliance is a product thermal efficiency rating determined under continuous operating and was determined independently of any installed system.

## **FOR SAFE INSTALLATION AND OPERATION OF YOUR GAS STOVE PLEASE NOTE THE FOLLOWING:**

1. This appliance gives off high temperatures and should be located out of heavy traffic areas and away from furniture and draperies.
2. Children and adults should be alerted to the hazards of the high surface temperatures of this appliance and should stay away to avoid burns or ignition of clothing.
3. Children should be carefully supervised when they are in the same room as your fireplace appliance.
4. Under no circumstances should this appliance be modified. Any parts that have to be removed for servicing should be replaced prior to operating this appliance.
5. Installation and any repairs should be done by a qualified service person. A professional service person should be called to inspect this appliance annually. Make it a practise to have all gas appliances checked annually.
6. Control compartments, burners and air passages in this appliance should be kept clean and free of dust and lint. Make sure that the gas valve and pilot are turned off before you attempt to clean this unit.

7. The venting system (chimney) of this appliance should be inspected at least once a year and if needed, your venting system should be cleaned.
8. Keep the area around your appliance clear of combustible materials, gasoline and other flammable vapours and liquids. This appliance should not be used as a drying rack for clothing nor should Christmas stockings or decorations be hung from it.
9. Under no circumstances should any solid fuels ( wood, paper) be used in this appliance.
10. For safe operation, purge gas line with glass door removed to assure a continuous flow of gas to the burner. Glass doors must be installed for stove to operated safely.
11. Do not use this heater if any part has been under water. Immediately call a qualified service technician to inspect the heater and to replace any part of the control system and any gas control which has been under water.
12. Do not operate appliance unless completely installed as per installation instructions.

## LOCATING YOUR APPLIANCE

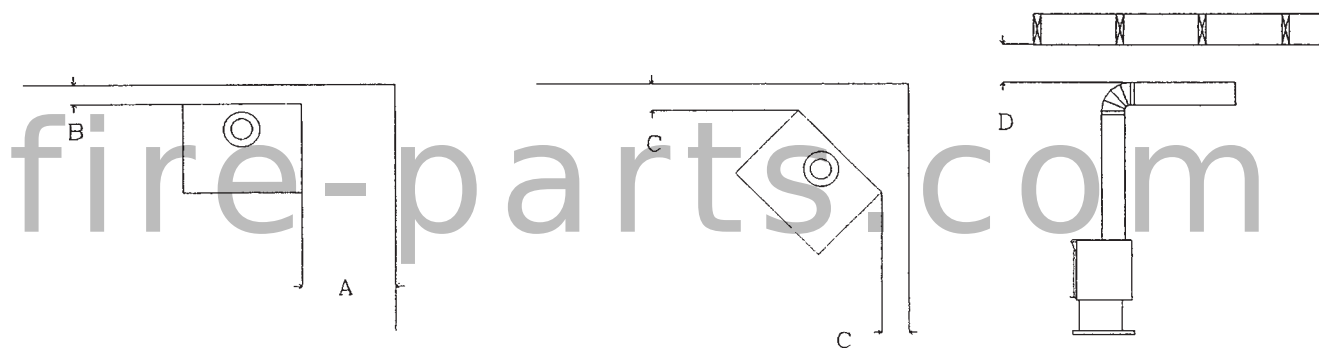

**THE FOLLOWING MINIMUM DISTANCES TO COMBUSTIBLES MUST BE OBSERVED TO ENSURE SAFE OPERATION OF YOUR STOVE.**

	Minimum distance to combustibles
A	6" from side of unit
B	4" from back of unit
C	3" from side of unit in corner (45° ) installation
D	4" from top of 90° elbow
E	2-1/2" from top of horizontal pipes, all other existing pipes 1" clearances to combustibles.

The unit should be placed on a hard, stable surface. The appliance may be installed directly on carpeting, tile or other combustible material with no additional floor protection being required.

This unit has been tested in a Alcove the minimum size of Alcove is Depth 30", Height 60", Width 36".

## GAS LINE INSTALLATION

This gas appliance should be installed by a qualified installer in accordance with local building codes and with current CAN/CGA-B149.1 or .2 installation codes for Gas Burning Appliances and Equipment in Canada and the National Fuel Gas Code Z223.1 in the United States.

**NOTE: IF THE OPTIONAL FAN KIT IS TO BE INSTALLED IT IS HIGHLY RECOMMENDED THAT IT BE ATTACHED TO THE STOVE BEFORE THE STOVE IS PUT IN ITS FINAL POSITION.**

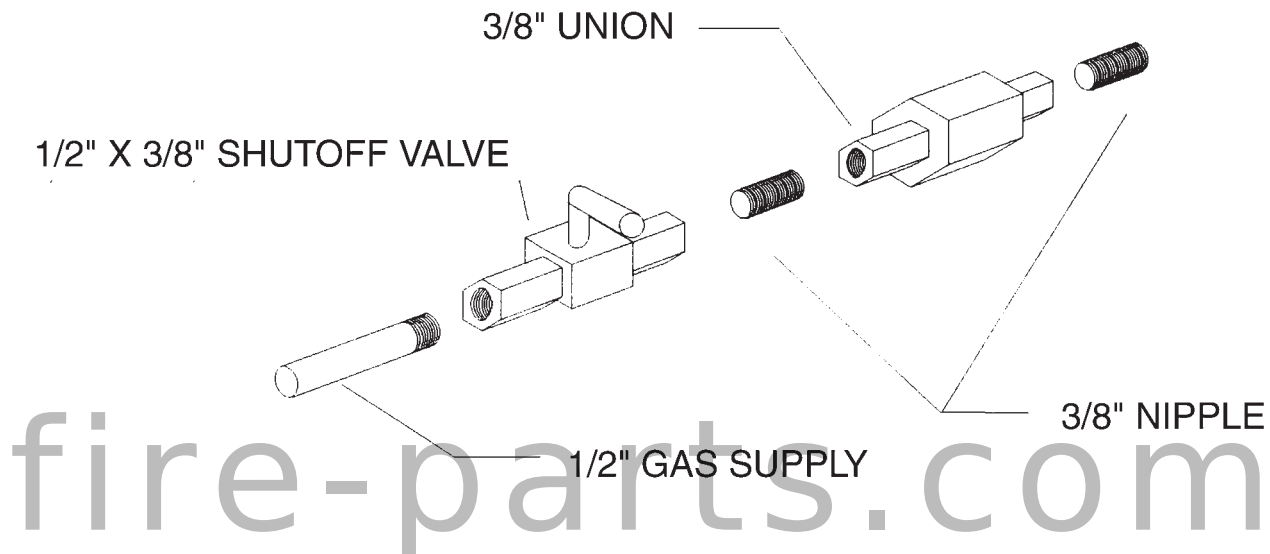

1. The gas pipeline is brought into the unit on the back left side of the unit.
2. The gas control inlet is 3/8". Typical installation layout for rigid pipe is shown below.
3. When using copper or flex connector, use only approved fittings. Always provide a union so that gas line can be easily disconnected for burner or fan servicing. See gas specification for pressure details and ratings.
4. When a vertical section of gas pipe is required for installation, a condensation trap is needed. See CAN/CGA-B149.1 or .2 for code details.
5. For natural gas, a minimum of 3/8" iron pipe with gas minimum pressure of 4.5" w.c. must be used for supply from the gas meter. Consult with the local gas utility if any questions arise concerning pipe sizes.
6. 1/8" NPT plugged tapings are accessible for test gauge connection both on the inlet and outlet of the gas valve.
7. Turn the gas supply ON and check for leaks. **DO NOT USE OPEN FLAME FOR THIS PURPOSE.** Use an approved leak testing solution.
8. The appliance and its individual shutoff valve must be disconnected from the gas supply piping system during any pressure testing of that system at test pressures in excess of 1/2 PSIG (3.5 KPa).
9. The appliance must be isolated from the gas supply piping system by closing its individual shutoff valve during any pressure testing of the gas supply piping system at test pressures equal to or less than 1/2 PSIG (3.5 KPa).

NOTE: The gas line connection may be made of 1/2" rigid pipe, 1/2" copper pipe or an approved flex connector. Since some municipalities have additional local codes, it is always best to consult your local authorities and the current CAN/CGA-B149.1 or .2 installation code in Canada or the National Fuel Gas code ANSI Z223.1 in the U.S.A.

For the state of Massachusetts a **T-handle gas shut-off valve** must be used on a gas appliance. This T-handle gas shut-off valve must be listed and approved by the state of Massachusetts. This is in reference to the state of Massachusetts state code CMR238.

**IMPORTANT: Always check for gas leaks with a soap and water solution.  
Do not use open flame for leak testing.**

## GAS SPECIFICATIONS

FUEL CONTROL	GAS	MAXIMUM INPUT (BTU)		MAXIMUM OUTPUT (BTU)	
		HIGH	LOW	HIGH	LOW
NATURAL GAS	MILLIVOLT	30,000	20,000	23,100	15,400
PROPANE GAS	MILLIVOLT	30,000	20,000	23,400	15,600

MAXIMUM EFFICIENCY	
GAS INLET SIZE	3/8"(SIT)

GAS SUPPLY PRESSURE	MINIMUM	NORMAL (INCHES WATER COLUMN)	MAXIMUM
NATURAL GAS	5.5	7	9
PROPANE GAS	11	11	12

	MANIFOLD PRESSURE (INCHES WATER COLUMN)
NATURAL GAS	3.5
PROPANE GAS	10

(0-4500 FT)	ORIFICE SIZE	AIR SHUTTER
NATURAL GAS	# 36	.125"
PROPANE	# 51	.437"

## OPERATING AND MAINTENANCE INSTRUCTIONS

This gas appliance should be installed by a qualified installer in accordance with local building codes and with current CAN/CGA-B149.1 or .2 installation codes for Gas Burning Appliances and Equipment.

**WARNING: WHEN PURGING THE GAS LINE, THE GLASS FRONT MUST BE REMOVED.**

### FOR SAFE INSTALLATION AND OPERATION NOTE THE FOLLOWING:

This appliance gives off high temperatures and should be located out of heavy traffic areas and away from furniture and draperies.

Children and adults should be alerted to the hazards of high surface temperatures of this appliance and should stay away to avoid burns or ignition of clothing.

Control compartments, burners and air passages in this appliance should be kept clean and free of dust and lint. Make sure that the gas valve and pilot light are turned off before you attempt to clean this unit.



The venting system (chimney) of this appliance should be inspected at least once a year and if needed, your venting system should be cleaned.

Keep the area around your appliance clear of combustible materials, gasoline and other flammable vapours and liquids.

Under no circumstances should this appliance be modified. Parts that have to be removed for servicing should be replaced prior to operating this appliance again.

Installation and any repairs to this appliance should be done by a qualified service person. A professional service person should be called to inspect this appliance annually. Make it a practice to have all of your gas appliances checked annually.

Never use your gas stove as a cooking device.

The Burner/Log Assembly has been engineered and permanently adjusted for proper flame control.

**DO NOT ALTER GAS ORIFICE.**

Periodically remove the logs from the grate assembly and vacuum any loose particles from the grate and burner areas.

This appliance should not be used as drying rack for clothing, nor should Christmas stockings or decorations be hung near it.

Under no circumstances should any solid fuels (wood, paper, cardboard, coal) be used in this appliance.

NOTE: it is normal for your gas stove to give off some odour the first time it is burned. This is due to the curing of the paint and any undetected oil from the manufacturing process.

Please ensure that your room is well ventilated - open all windows.

It is recommended that you burn your gas stove for at least four (4) hours the first time you use it without the fan on.

## **GENERAL GLASS INFORMATION**

### **GLASS CLEANING**

It will be necessary to clean the glass periodically. During start-up, condensation, which is normal, forms on the inside of the glass and causes dust, lint etc. to cling to the glass surface. Also, initial paint curing can deposit a slight film on the glass. It is therefore recommended that initially the glass be cleaned two or three times with non-abrasive common household cleansers and warm water. After that, the glass should be cleaned two or three times a season depending on the circumstances.

## **CAUTIONS AND WARNINGS**

**DO NOT CLEAN WHEN THE GLASS IS HOT.  
THE USE OF SUBSTITUTE GLASS WILL VOID ALL PRODUCT WARRANTIES.  
CARE MUST BE TAKEN TO AVOID BREAKAGE OF THE GLASS.  
DO NOT OPERATE THIS STOVE WITHOUT THE GLASS DOORS OR WITH A BROKEN GLASS DOOR.  
DO NOT STRIKE OR ABUSE GLASS.**

### **GLASS REPLACEMENT**

Only Robax ceramic or coated Neoceram glass may be used for replacement. It must be a minimum of 5mm thick.

### **REMOVAL OF FRONT DOOR**

1. Remove top front grill by gently lifting the grill up and pulling towards you.
2. Remove the two screws on top of the door. Then lift the door out of door rest.

### **REPLACING OF CERAMIC GLASS**

Follow Removal of Front Door then clean all materials from door frame. Using a high temperature sealant (temperature-resistant to 500°F (260°C)) apply a bead of approximately 1/8" to all four sides of frame and insert glass with new gasket. Frame should be placed on a flat surface with a small amount of weight pressing glass into sealant. Let dry approximately 15 to 20 minutes. The door can be reinstalled by reversing Steps 1,2.

## **LOG ASSEMBLY**

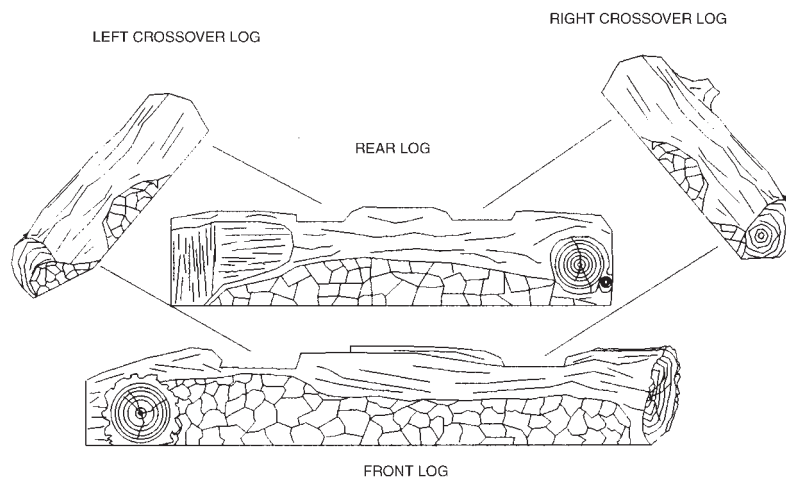

1. Remove front door as described above.
2. Remove logs from carton (4) and inspect.
3. Centre rear log on rear log holder attached to back of firebox above and to the rear of the pilot burner.
4. Centre front log on front burner and pull it up against the grate. When correctly installed the log should not cover any of the holes in the front burner. Place the back log on the shelf (located on back of unit) until it rests against the back of the unit.
5. Place top logs across the front and rear logs in the slots provided.
6. Purge gas lines and test pilot operation **WHILE DOOR IS STILL OFF.**
7. Tear ember wool into small, thin, irregular pieces and place evenly over the front burner.
8. Replace glass door. The door must be installed before operating the fireplace.

# LOGG5 OR LOGF5 PLACEMENT GUIDELINES

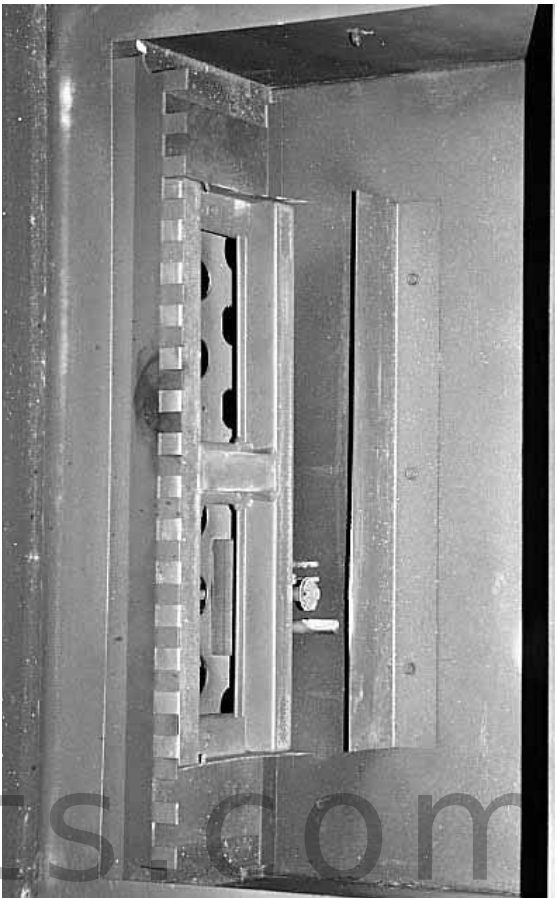

**Step (1)** Remove logs from carton and inspect each log.

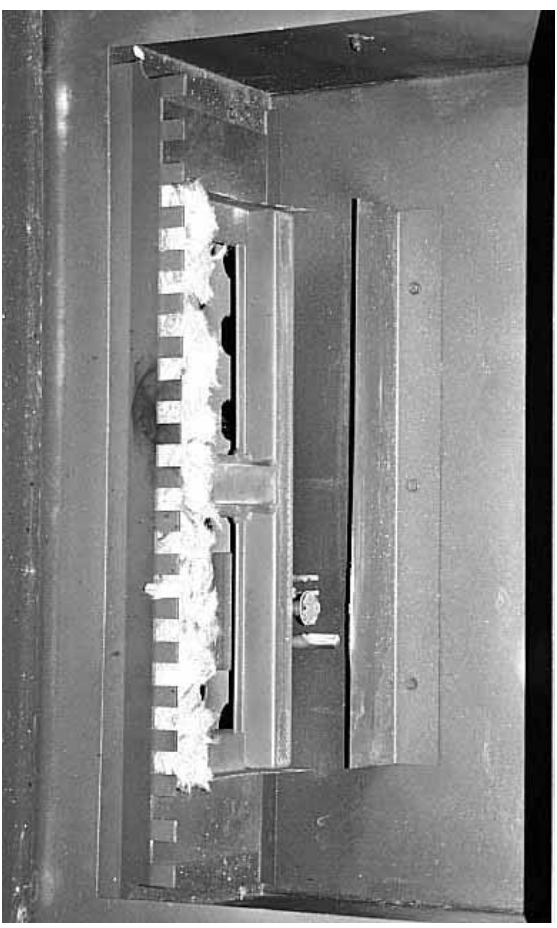

**Step (2)** Break glowing embers into thumbnail size. Place glowing embers evenly on to the front burner. Do not go over the grate.

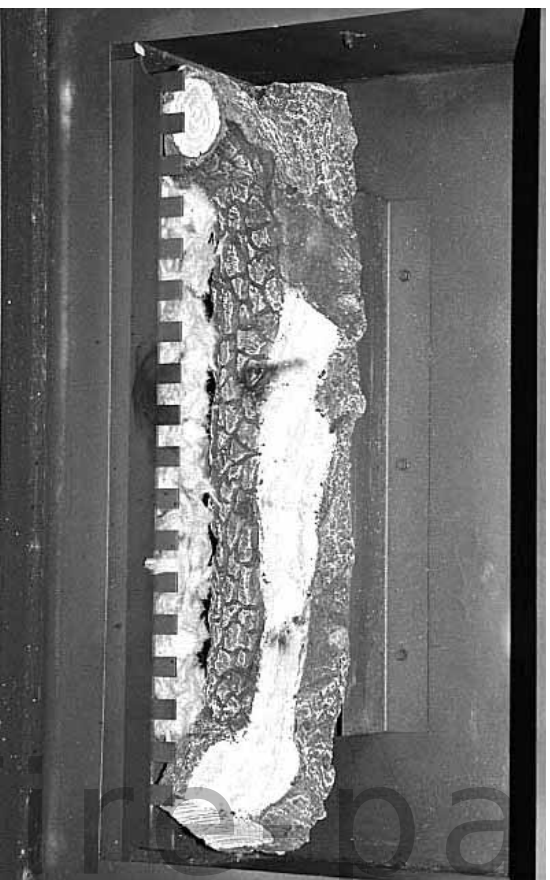

**Step (3)** Place front log over front burner with the left & right sides against the front grate.

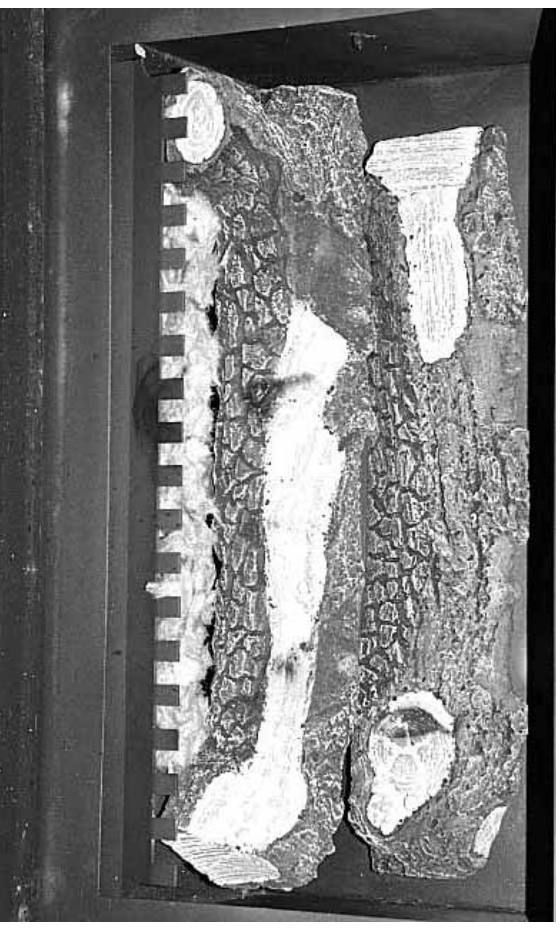

**Step (4)** Place rear log on to the log retainer.

## LOGC5 OR LOGF5 PLACEMENT GUIDELINES (continued)



**Step (5)** Place right crossover log into the slots that are provided. Bark should be to the outside.



**Step (6)** Place left crossover log into the slots that are provided. Bark should be to the outside.

**Step (7)** Purge lines and test pilot operation.

**Step (8)** Replace glass door.

fire-parts.com

## OPTIONAL FAN KIT INSTALLATION

### NOTE:

**FOR EASE OF INSTALLATION THE FAN KIT SHOULD BE INSTALLED BEFORE THE STOVE IS PUT IN ITS FINAL POSITION.**

### AUTOMATIC ON/OFF THERMOSTAT CONTROLLED FAN KIT (Part #F35FK)

1. The sensor is mounted under the fire box on a Z-bracket. Ensure that the sensor is secure.
2. Open the pedestal door on the front of the stove. Secure the fan On/Off switch in the hole provided next to the piezo-ignitor being sure that the small set screw for setting minimum fan speed is facing towards the back of the stove.
3. Remove the two screws on either side of the large rectangular opening under the stove. Install the fan unit over the rectangular opening and secure it using the two screws.
4. Connect the power, sensor and variable speed switch as shown in the wiring diagram on page 14
5. Turn the switch on (clockwise). **Note: The stove must now be installed and gas lines attached before proceeding.**
6. Turn the stove on. Once the sensor unit reaches operating temperature (in approximately 10 to 15 minutes) the fan will turn on. The fan can be switched off, if desired, by turning the switch fully counter-clockwise.
7. Once the fan has started to turn it may be desirable to adjust the minimum fan speed. Remove the variable speed switch from its mountings. Turn the variable speed wall controller to its minimum setting (fully clockwise). Use the set screw on the side of the variable speed controller to increase or decrease the minimum fan speed. (It may be desirable to lower minimum fan speed to decrease the sound level created by the fan.) Reinstall switch into its mountings and cover the face plate.

## FV/FDV 5000 OPTIONAL FAN KIT INSTALLATION

**Caution: Do not connect any wires from the fan assembly to the Gas Valve.**

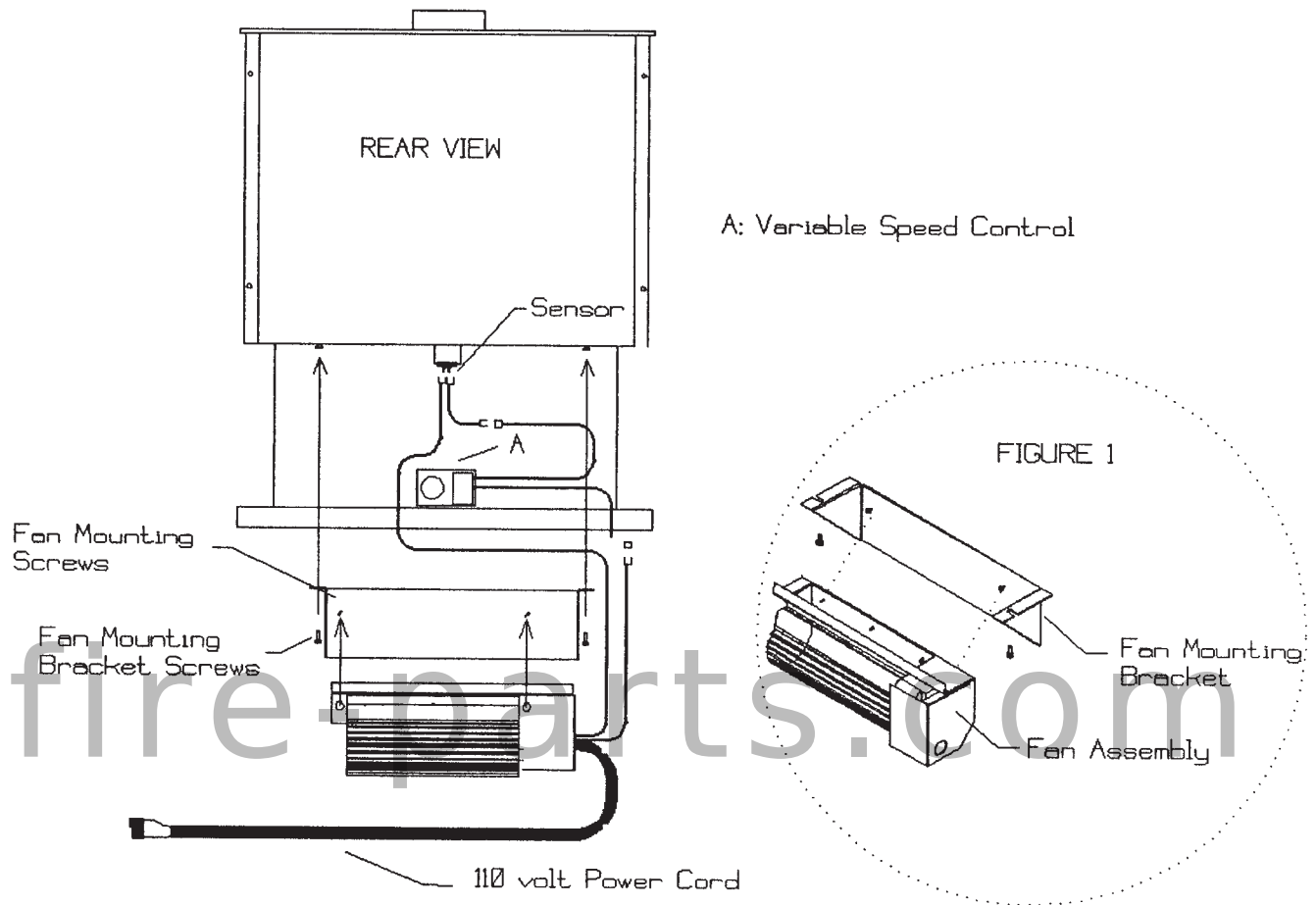

**NOTE: FOR EASE OF INSTALLATION THE FAN KIT SHOULD BE INSTALLED BEFORE THE STOVE IS PUT IN ITS FINAL POSITION.**

### AUTOMATIC ON/OFF THERMOSTAT CONTROLLED FAN KIT (Part #F35FK)

1. Open Access Door where the piezo-igniter is located and install the variable speed control in the hole provided opposite the piezo-igniter.
2. Locate the two fan mounting bracket screws in the rear of the unit as shown in the above diagram Fig.1, remove one of the screws and loosen the other screw. Place the fan mounting bracket in position and tighten screws.
3. Locate the two fan mounting screws as shown in the diagram and place the key holes on the fan over the mounting screws and drop into position.
4. Connect the wires to the sensor and variable speed control as shown in the diagram. Connect the fan extension cord to 110volt power.
5. Turn the variable speed control to the on position (clockwise). NOTE: The stove must now be installed and gas line attached before proceeding.
6. Turn the stove on. Once the sensor unit reaches operating temperature (in approximately 10 to 15 minutes) the fan will turn on. The fan can be switched off, if desired by turning the switch fully counter-clockwise.
7. Once the fan has started to turn it may be desirable to adjust the minimum fan speed. Tilt the control panel forward to access the rear of the variable speed switch, turn the variable speed switch to its minimum setting (fully clockwise). Use the set screw on the side of the variable speed control to increase or decrease the minimum fan speed. (It may be desirable to lower minimum fan speed to decrease the sound level created by the fan.) Reinstall the control panel.

# MILLIVOLT SYSTEM, LIGHTING, & BURNING CONTROL

## LIGHTING INSTRUCTIONS

1. Open access door on front of unit.
2. Push in gas control knob slightly and turn clockwise to "OFF". NOTE: Knob cannot be turned from "PILOT" to "OFF" unless knob is pushed in slightly. Do not force.
3. Wait five (5) minutes to clear out any gas remaining in burner combustion chamber.
4. Turn knob on gas control counter-clockwise to "PILOT".
5. Push in control knob all the way and hold in. Immediately light the pilot with piezo-electric ignitor while continuing to push knob in for one (1) minute. Release knob. Pilot should remain lit. If it goes out, repeat steps 2 through 5 until pilot remains lit. - If knob does not pop up when released, stop and immediately call your service technician or gas supplier. - If pilot will not stay lit after several tries, turn the gas control knob to "OFF" and call your service technician or gas supplier.
6. Turn gas control knob counter-clockwise to "ON".
7. All models are supplied with a switch that turns the main burner on or off. This switch which is located next to the piezo-electric igniter must be turned to on in order for the main burner to light. (Be sure switch is connected to valve.)
8. Adjust the gas flow (flame height) with the HI/LO gas control knob on valve to the desired level.

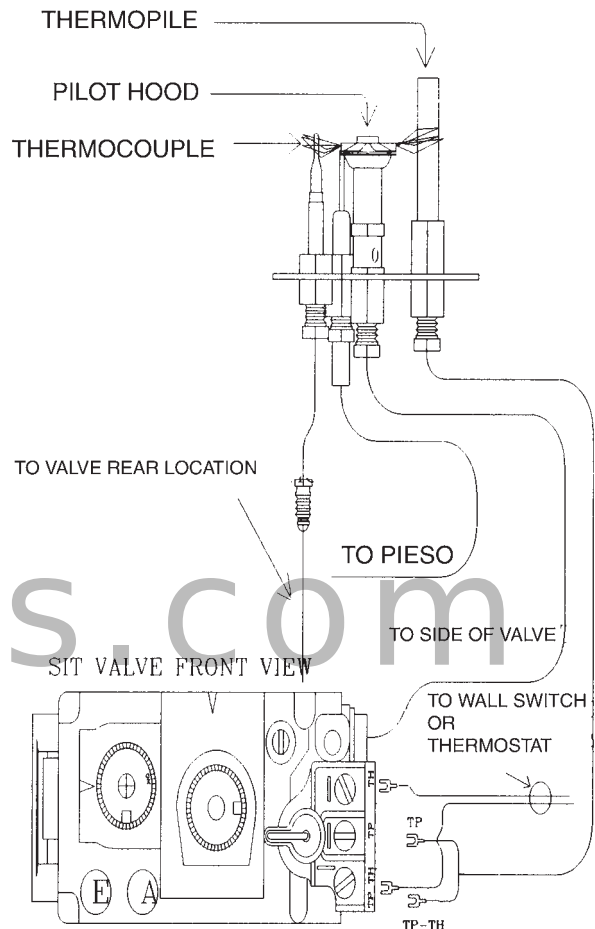

## TO TURN OFF GAS APPLIANCE

Turn off all electric power to the appliance if service is to be performed. Open control access door. Push in gas control knob slightly and turn clockwise to "OFF". Do not force. Close control access door.

## Pilot Burner Adjustment

1. Locate pilot adjustment (up and to the right approximately 1/2" from Hi/Low control).
2. Adjust pilot screw to provide proper sized flame (clockwise decreases height, counter clockwise increases height).
3. Leak test.

**NOTE:** The "On/Off" switch may be replaced with a wall thermostat which allows the main burner to light and turn off automatically depending upon the thermostat setting and room temperature.

# Vent Termination

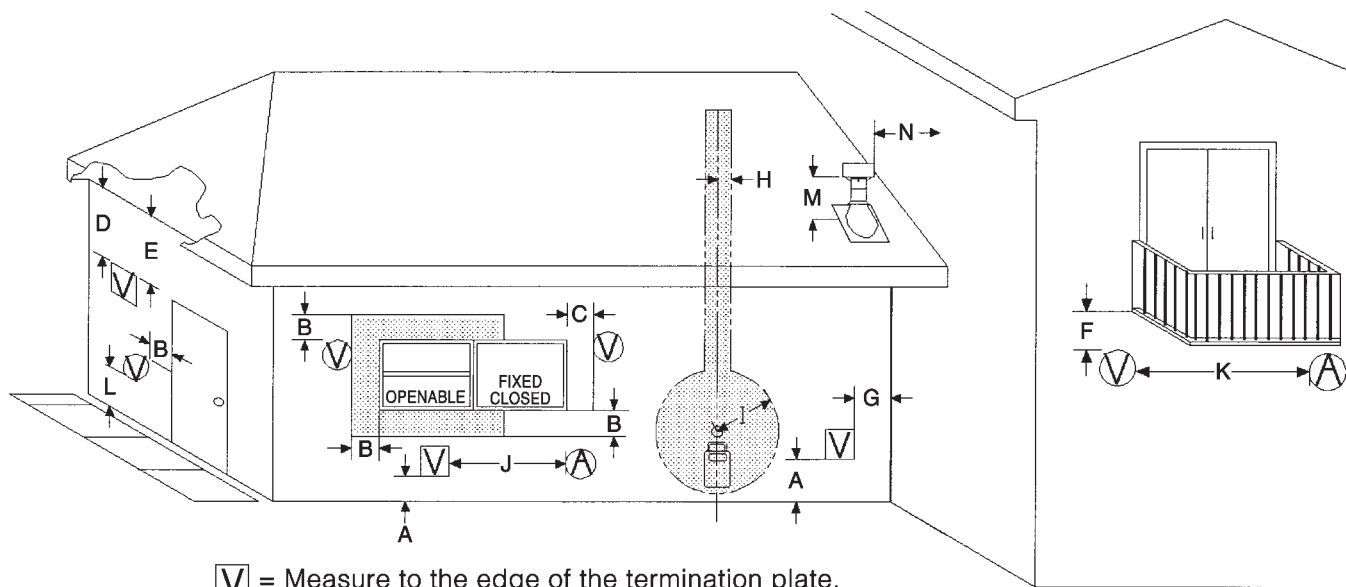

☐V = Measure to the edge of the termination plate.

○V = Measure to the edge of the round termination.

☐V Vent Terminal

○ Air Supply

■ Area Where Terminal Not Permitted.

- A - Clearance above grade, veranda, porch, deck, or balcony 12 inches (30cm) minimum.<sup>1,2</sup>
- B - Clearance to window or door that may be opened. 12 inches (30cm) minimum for appliances 100 000 Btuh (30 kW) and lower, in Canada. 9 inches<sub>2</sub> (23cm) for appliances 50 000 Btuh and lower, in USA.
- C - Clearance to permanently closed window minimum 12 inches (30cm) recommended to prevent condensation on window, in Canada. 9 inches<sub>2</sub> (23cm) for appliances 50 000 Btuh and lower, in USA.
- D - Vertical clearance to ventilated soffit located above the termination within a horizontal distance of 2 feet (60cm) from the center line of the termination. 18 inches (46cm) minimum.<sub>3</sub>
- E - Clearance to unventilated soffit 12 inches (30cm) minimum.
- F - Clearance under veranda, porch, deck or balcony 12 inches<sub>1</sub> (30cm) minimum.<sub>4</sub> US<sub>5</sub>
- G - Clearance from a perpendicular inside wall or outer corner to the edge of the vent terminal plate is 3" (minimum).
- H - Clearance to each side of center line extended above meter/regulator assembly 3 feet (91cm) within a height 15 feet (4.5m) above the meter/regulator assembly.
- I - Clearance to service regulator vent outlet 3 feet (91cm) minimum.<sub>1</sub> US<sub>5</sub>
- J - Clearance to non-mechanical air supply inlet to building or the combustion air inlet to any other appliance, in Canada, 12 inches<sub>1</sub> (30cm) minimum for appliances 100,000 Btuh (30kW) and lower. In the USA, 9 inches<sub>2</sub> (23cm) for appliances 50 000 and lower.
- K - Clearance to a mechanical air supply inlet 6 feet (1.8m) minimum.<sub>1</sub> in Canada. In USA, 3 feet (91cm) above if within 10 feet<sub>2</sub> (3m) horizontally.
- L - Clearance above paved sidewalk or a paved driveway located on public property 7 feet (2.1m) minimum.<sub>3</sub>
- M - Clearance above highest point of exit on roof 18 inches (45cm).
- N - Clearance to perpendicular wall 24 inches (60 cm). (Recommended to prevent re-circulation of exhaust products. For additional requirements check local codes.)

**NOTE: Clearances are to the edge of terminal plate, add 6-3/4" to clearances to arrive at center line.**

**NOTE: Local Codes or Regulations may require different clearances.**

## Termination

It is imperative that the vent termination be located observing the minimum clearances as shown. There must not be any obstruction such as bushes, garden sheds, fences, decks or utility buildings within 24" from the front of the termination plate.

Do not locate termination where excessive snow or ice build-up may occur. Be sure to check vent termination area after snow falls and clear to prevent accidental blockage of venting system. When using snow blowers, make sure snow is not directed towards vent termination area.

## General Venting Information

The gas fireplace is approved to be vented either through the side wall or vertically through the roof.

This appliance is approved with Kingsman flex vent system and also approved for use with Simpson Duravent Direct Vent System (model DV-GS series), and AmeriVent Direct Vent pipe system.

Kingsman flex vent system can be used with Simpson Duravent Direct Vent termination's (model DV-GS series).

When using Simpson Duravent Direct Vent pipe or AmeriVent and Direct vent pipe, a Kingsman/Duravent adapter must be used.

**ONLY VENTING COMPONENTS SPECIFICALLY APPROVED AND LABELLED FOR THIS FIREPLACE MAY BE USED.**

Minimum clearance to combustibles on venting is 1" with the following exceptions as follows: top of horizontal pipe 2<sup>1</sup>/<sub>2</sub>", top of 90 degree pipe 4".

Venting terminal shall not be recessed into a wall or siding.

1 - As specified in CGA B149 installation codes (1991).

2 - Only permitted if veranda, porch, deck, or balcony is fully open on a minimum of two sides beneath the floor.<sub>1</sub>

3 - A vent shall not terminate directly above a sidewalk or paved driveway which is located between two single family dwellings and serves both dwellings.



## TERMINATION

It is imperative that the vent termination be located observing the minimum clearances as shown. There must not be any obstruction such as bushes, garden sheds, fences, decks or utility buildings within 24" from the front of the termination.

Do not located termination where excessive snow or ice build-up may occur. Be sure to check vent termination area after snow falls and clear to prevent accidental blockage of venting system. When using snow blowers, make sure snow is not directed towards vent termination area.

## GENERAL VENTING INFORMATION

The gas stove is approved to be vented either through the side wall or vertically through the roof. **Only Kingsman venting kits and components specifically approved and labelled for this stove may be used.** This appliance is also approved for use with Simpson-DuraVent Direct Vent system, Model DV-GS Series.

### SIMPSON DURAVENT

When using Simpson DuraVent pipe a DuraVent adapter must be used (part # ZDVDFa for fireplaces or ZDVdKa for stoves or back flue model fireplaces). Follow installation instructions provided by Simpson DuraVent for installation of pipe and adhere to the clearance to combustibles provided in this manual. Apply a bead of Mill Pack high temp sealant to all joints of pipes, adapters and termination.

Minimum clearances on venting (4" to top of elbow), (2-1/2" from top of horizontal pipes), (1" on all other existing pipes). **REMEMBER THAT A 1/4" VERTICAL RISE IS REQUIRED FOR EVERY 12" OF HORIZONTAL RUN.**

Venting terminal shall not be recessed into a wall or siding.

### VENTING ROUTES AND COMPONENTS

Since it is very important that the vent system maintain its balance between the combustion air intake and the flue gas exhaust, certain limitations as to vent configurations apply and must be adhered to.

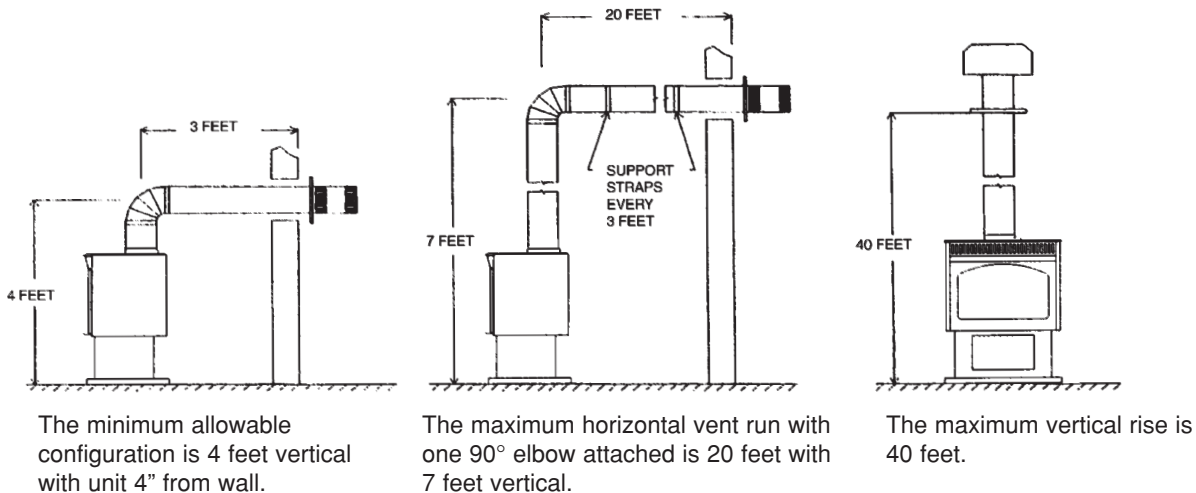

The maximum number of 90° elbows per installation is three (3). For each additional 90° elbow, the horizontal runs must be reduced by 36" per 90° elbow. See venting chart on page 16 for total horizontal and vertical runs.

For each 45° elbow installed in the horizontal run, the length of the horizontal run must be reduced by 18" (45 cm). This does not apply if the 45° elbows are installed on the vertical part of the vent system. 45° elbows can be installed in either the horizontal or vertical runs.

**IMPORTANT: ALWAYS LOCATE THE STOVE IN SUCH A WAY AS TO MINIMIZE THE NUMBER OF OFFSETS AND/OR HORIZONTAL RUNS. A 1/4" VERTICAL RISE IS REQUIRED FOR EVERY 12" OF HORIZONTAL RUN.**

The following table shows the relationship between vertical and horizontal vent lengths and will help you to determine the correct vent lengths for optimum stove performance.

**HOW TO USE THE VENT TABLE**

1. Determine the height of the system and the number of elbows required.
2. Use the Venting Chart to determine the maximum horizontal distance allowed.

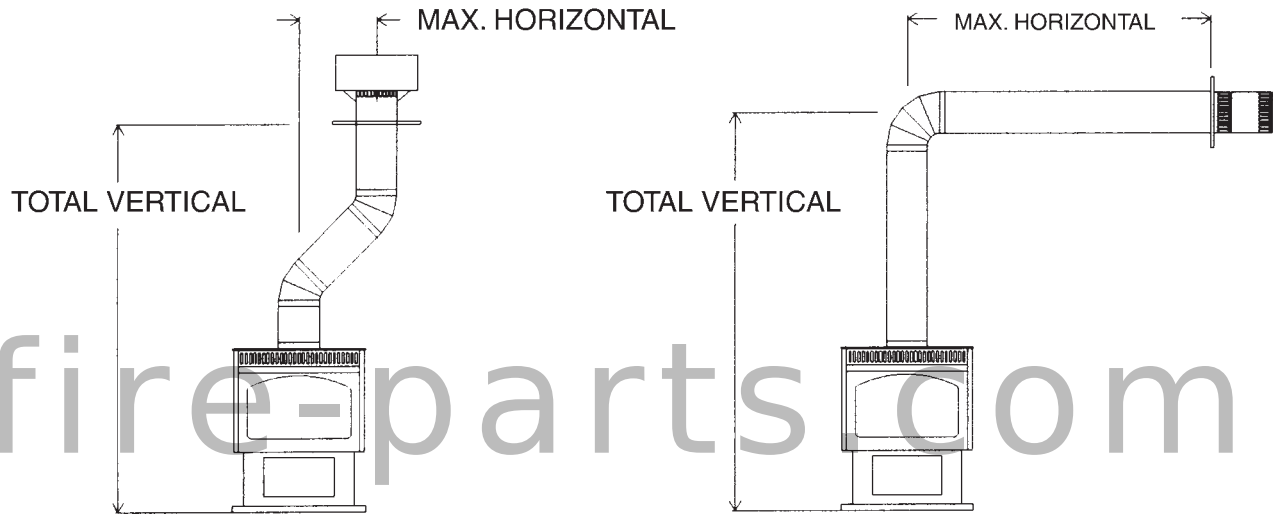

Total Vertical		Max. Total Horizontal	
Feet	Meters	Feet	Meters
4	1.2	3	0.9
5	1.5	4	1.2
6	1.8	8	2.4
7	2.1	20	6.1
8	2.4	20	6.1
9	2.7	20	6.1
10	3.0	20	6.1
11	3.4	20	6.1
12	3.7	20	6.1
13	4.0	20	6.1
14	4.3	20	6.1
15	4.6	20	6.1
16	4.9	20	6.1
17	5.2	20	6.1
18	5.5	20	6.1
19	5.8	20	6.1
20	6.1	20	6.1
25	7.5	15	3.0
30	9.0	0	0

**Note:** For each 45° elbow installed in the horizontal run, the length of the horizontal run must be reduced by 18" (45 cm). This does not apply if the 45° elbows are installed on the vertical part of the vent system.

**Note:** For each additional 90° elbow installed in the horizontal run, the length must be reduced by 36" (90 cm). Maximum number of 90° elbows are three per installation.

## VENT PIPE ASSEMBLY

Before joining the four inch flex pipe to stove or vent termination apply a bead of **high temperature sealant (MIL PAC SEALANT IS RECOMMENDED)** to the pipe and secure it with the clamp provided. If two pieces of 4" flex pipe are to be joined, the joint must be siliconed and secured with (4) screws.

Before joining 7" pipe to elbows, stove and vent termination apply a bead of high temperature silicone to crimped end of elbow or pipe. Join pipes and secure with three (3) sheet metal screws.

The maximum number of 4" flexible pipe connections permitted is two (2) excluding the stove and air terminal connections although a maximum of one is the most which is recommended.

**It is critical to the proper and safe operation of this stove that all connections are both caulked with liberal amounts of sealant and secured with clamps or screws. Do not use any kind of tape or silicone other than that recommended in this manual.**

## HORIZONTAL VENT INSTALLATION

fire-parts.com

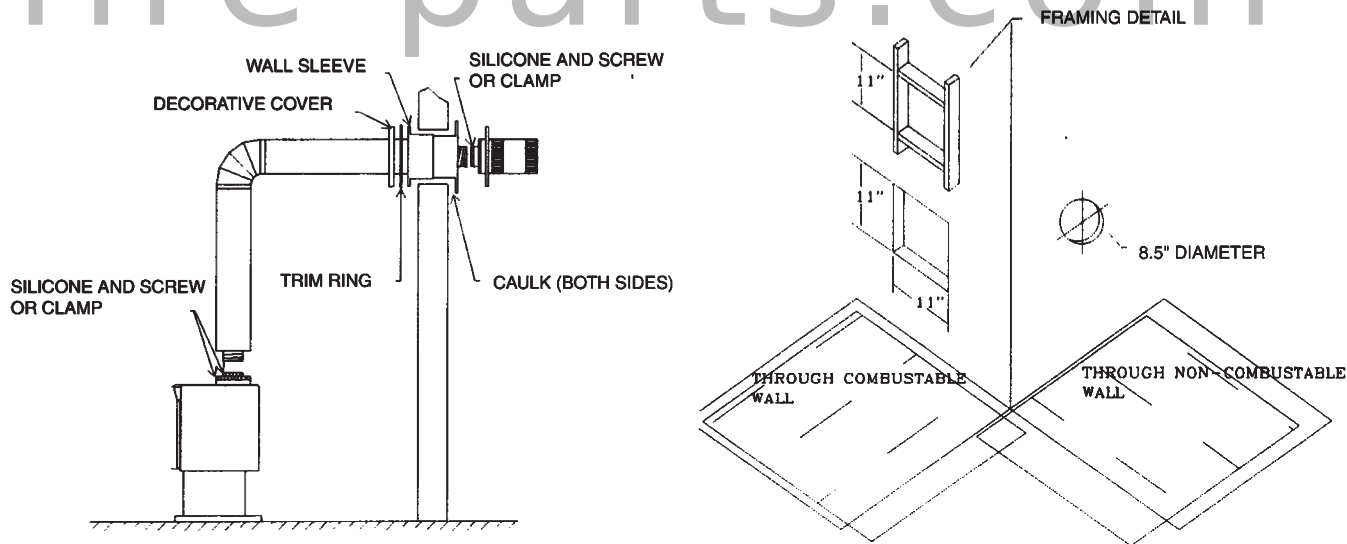

1. Determine the location of vent termination on wall assuring clearances are maintained as listed in the Vent Termination Location Chart.
2. Once location has been determined, cut or frame a hole in the exterior wall with a minimum 8 1/2" diameter in non-combustible wall or frame 11" x 11" ID in combustible wall. (See Figure 2)
3. Install zero clearance wall sleeve to inner and outer wall being sure to use caulking around the wall thimble to weatherproof.

**Note: The Zero Clearance Wall Sleeve and vent termination must not be recessed into the exterior wall or siding.**

4. If optional fan kit has been purchased it should now be installed before stove is placed in its final position.
5. Place stove into position. Determine the lengths of the vertical and horizontal 7" pipes. Cut the 7" pipes to the correct length assuring that the following conditions have been met:
  - (i) **The horizontal 7" pipe should not extend past the outer portion of zero clearance wall sleeve.**
  - (ii) **There must be a 1/4" rise per foot on horizontal pipe.**
  - (iii) **A clearance to combustibles of 2-1/2" must be maintained for the top of a horizontal pipe.**
  - (iv) **The clearance to combustibles above the elbow must be 4 inches.**
  - (v) **Clearance of one inch on all other pipes.**

Before joining 90° elbow and pipes, apply a bead of high temperature sealant (**Mil Pac**) to crimped end of elbow or pipe. Join pipes to 90° elbow and secure joints with three (3) sheet metal screws, **pipe should overlap on connection of each pipe by 1-1/2"**.

6. Feed the 4" flex pipe through the 7" pipes. If the 4" flex pipe has been expanded do not try to depress it as this can obstruct air flow and affect the performance of the unit. The only time this may be unavoidable is when installing the vent terminal.

**Note: Do not remove or move spacer springs attached to 4" inner flex pipe, these must be used to assure an 1-1/4" air gap between 4" and 7" pipes. Minimum distance between spacer springs should be 2 FT, a 90 degree elbow requires a spring at the start of the elbow and the end of the elbow.**

7. Position 7" pipes with 4" flex pipes installed into final position being sure to install decorative trim plate and trim ring. Attach 4" flexible pipe to stove with 1/4" bead of sealant and secure with (4) screws. Attach 7" pipe to stove with sealant and screws.
8. Expand the 4" flex pipe three inches past the 7" rigid pipe at the vent terminal, just enough to allow for the sealant and securing with (4) screws to the 4" pipe to the terminal. Attach the vent terminal to 4" flex pipe with (4) screws. Apply sealant to 7" pipe on terminal and gently push the vent terminal into the horizontal section as straight as possible. Attach the terminal to the exterior wall with screws provided. Apply caulking between the terminal and the wall to prevent rain and moisture from entering around the terminal.
9. Support horizontal pipes every three (3) feet (91 cm) with metal pipe straps.
10. Install decorative trim bands at the 7" pipe joints.

# VERTICAL VENT INSTALLATION

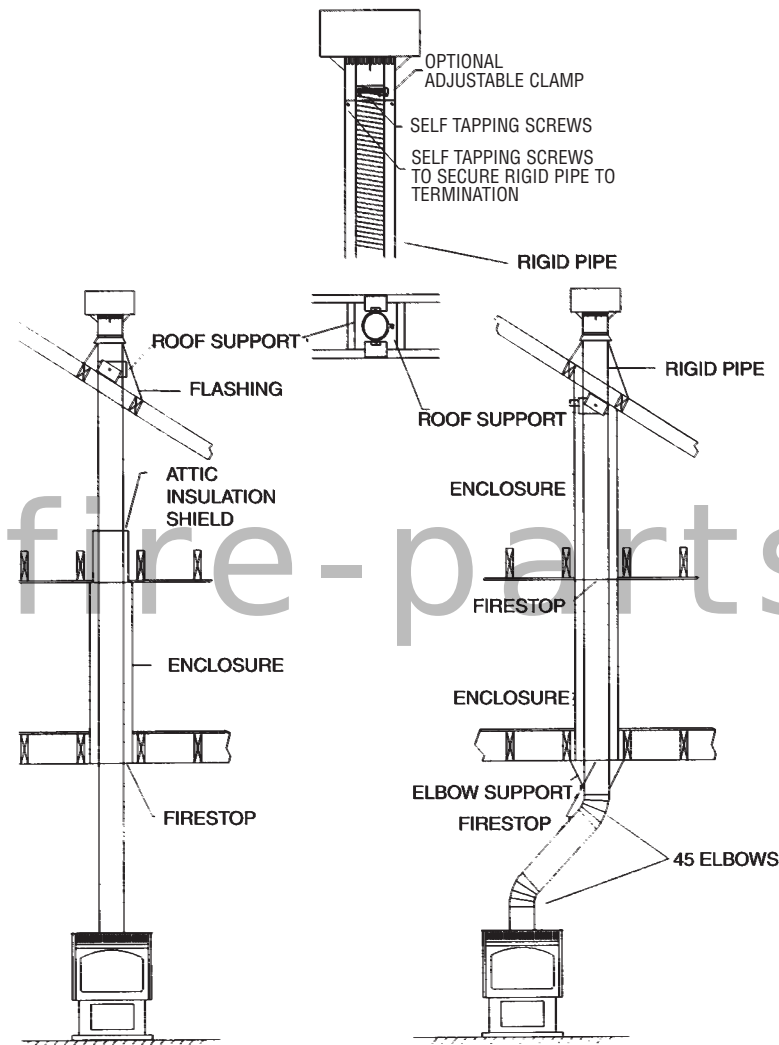

An Attic Insulation Shield must be installed where the vent passes from a lower living space into an attic space where the chimney is not enclosed. It is designed to keep insulation materials away from the chimney.

When installing the Attic Insulation Shield where the chimney passes from a living space to an attic space, install the shield from below and nail it in place using 1" spiral nails.

A firestop must be installed on the bottom side of the joists when passing through a ceiling or floor. If an attic insulation shield is to be used, a firestop is not required.

One pair (two) 45° elbows may be used to provide an offset in order to avoid cutting of joists and to clear other obstructions.

When using 45° elbows, an elbow support is required directly above the highest elbow.

Never install an elbow in a joist area. Vent sections must pass vertically through framed joist areas.

Maximum vertical height of system should not exceed 40 feet.

There are two vertical vent terminals, one for rises of 8 to 15 feet and another for rises of 15 to 40 feet. Be sure to use the correct one.

**Spacer springs to be installed on 4" flex pipe every 3 ft. on vertical runs. On 45° elbows or 90° elbows a spacer spring is needed on the start of the bend and on the end of bend.**

## VENTING KITS AND COMPONENTS

FDVHSK	<b>Horizontal Vent Starter Kit</b> Starter Kit Contains: Horizontal Vent Termination, Wall Thimble, Black Decorative Trim Ring, 7" Dia. Black Pipe 24" Length, 7" Dia. Black Pipe 48", 7" - 90° Black Elbow, 4" Dia. Flex 48" Unexpanded, 7" Brass Bands, (2) 7" Black Bands, Mill Pac.
FDVVSK	<b>Vertical Vent Starter Kit</b> Starter Kit Contains: Attic Insulation Shield, Decorative Ceiling Trim Ring, Black Band, Roof Support, Spacer Springs(6), Mill Pac
	<b>VENTING ACCESSORIES:</b> Vertical Vent Termination (ONLY) (Good to 15' Vertical) Vertical Vent Termination (ONLY) (For over 15' Vertical) Horizontal Vent Termination Horizontal Square Termination Safety Cage for Horizontal Termination Black Pipe (7" Diameter x 48") Black Pipe (7" Diameter x 36") Black Pipe (7" Diameter x 24") Black Pipe (7" Diameter x 12")
FDVVT15 FDVVT30 FDVHT FDVHSQ FDVHSC	
FDV48P FDV36P FDV24P FDV12P	
FDVE90 FDVE45	Black Elbow (7" Diameter x 90 Degree) Black Elbow (7" Diameter x 45 Degree)
ZDVAIS ZDVVOS ZDVFS ZDVRS ZDVSS ZDVWT	Attic Insulation Shield Offset Support Firestop Spacer Roof Support Siding Shield Wall Thimble (Horizontal Venting)
ZDV4FP8 ZDV4FP20 ZDV4FC	Flex Pipe 4" Diameter (4' Unexpanded to 8' Expanded) Flex Pipe 4" Diameter (10' Unexpanded to 20' Expanded) Flex Connector 4" Diameter
ZDVAAF ZDVAF2 ZDVAF3 ZDV7SC ZDVDKA	Flashing 7" c/w Storm Collar (1/12 to 7/12) Flashing 7" c/w Storm Collar (8/12 to 12/12) Flashing 7" c/w Storm Collar Flat Storm Collar 7 Inch Dura Vent/Kingsman Stove Adapter (FDV5000)

**LOG SET: required for each unit**

LOGF5	Log Set - Four Piece Fibre Split Oak (F5000, ZDV6000, VFI30)
LOGC5	Log Set - Four Piece Cast Split Oak (F5000, ZDV6000, VFI30)

**ACCESSORY LIST**

F35FK F5GG	Fan Kit w/Variable Speed Control (Temperature Sensing) Grill - Gold
F5ADDX F5ADG	Arch Door Frame - Deluxe Black (352) Arch Door Frame - Gold
Z1MT Z80PT ZIRC ZART DCHS	Thermostat Millivolt Wall Mount Thermostat Programmable Digital Millivolt Wall Mount (1F80-40) Remote Control Millivolt (On/Off with LED) (Model I) Remote Control Thermostat Millivolt (Model K) Remote Control Heatshield
FV7FBT F7DBC F7DTP	Decorative Brass Collar 7" Decorative Black Collar 7" Decorative Black Wall Trim Plate

## REPLACEMENTS PARTS

5000-190	Glass Ceramic (13.25 x 20")
5000-106	Grill Charcoal
5000-P025WS	Spring - For Pedestal Door (2 per)
1000-214	Piezo-Igniter
1000-306	Thermalcord for Door Frame
1000-216	On/Off Switch
1000-255-36	#36 Orifice NG
1000-255-51	#51 Orifice LP
6000-130	Explosion Felt
2000-080	Thermodisc Fan Sensor
2000-085	Variable Speed Switch (Fan)
EMBER-I	Glowing Ember Kit

### CONVERSION KIT (SIT valve only)

5000DV - CKLP	LP Conversion Kit
5000DV - CKNG	NG Conversion Kit

### VALVE SYSTEM PARTS (If Serial Number is LESS than 3089)

<b>5000-BNGSI</b>	<b>S.I.T. Valve System</b>
<b>5000-BLPSI</b>	<b>NG BURNER ASSEMBLY</b> (complete with valve)
1001-P035SI	<b>LP BURNER ASSEMBLY</b> (complete with valve)
1001-P129SI	ELECTRODE SPARKER 915.035 SIT
1001-P157SI	THERMOCOUPLE 450M UNIFIED SIT
1001-P159SI	ORIFICE PILOT LP 977.157 SIT
1001-P508SI	ORIFICE PILOT NG 977.159 SIT
1001-P605SI	HT CABLE 16- 028.508 SIT
1001-P606SI	PILOT BURNER LP 190.605 UNIFIED, SIT
1001-P633SI	PILOT BURNER NG 190.606 UNIFIED, SIT
1001-P634SI	VALVE NOVA LP HI-LO 0820633
1000-P136WR	VALVE NOVA NG HI-LO 0820634
	GENERATOR (GO1A-524)

### VALVE SYSTEM PARTS (If Serial Number is GREATER than or equal to 3089)

<b>5000-BNGSI</b>	<b>S.I.T. Valve System</b>
<b>5000-BLPSI</b>	<b>NG BURNER ASSEMBLY</b> (complete with valve)
1001-P069SI	<b>LP BURNER ASSEMBLY</b> (complete with valve)
1001-P216SI	ELECTRODE SPARKER 915.069 TC
1001-P167SI	THERMOCOUPLE TC 290.216
1001-P165SI	ORIFICE PILOT LP 977.167 SIT
1001-P508SI	ORIFICE PILOT NG 977.165 SIT
1001-P713SI	HT CABLE 16- 028.508 SIT
1001-P714SI	PILOT BURNER LP 190.713 CONVERTIBLE, SIT
1001-P633SI	PILOT BURNER NG 190.714 CONVERTIBLE, SIT
1001-P634SI	VALVE NOVA LP HI-LO 0820633
1000-P136WR	VALVE NOVA NG HI-LO 0820634
	GENERATOR (GO1A-524)

## Trouble Shooting The Gas Control System

**WARNING:** BEFORE DOING ANY GAS CONTROL SERVICE WORK, REMOVE THE GLASS FRONT.

**NOTE:** Before troubleshooting the gas control system, be sure external gas shut off is in the "On" position.

Problem	Possible Causes	Corrective Action
Spark igniter will not light.	Defective or misaligned electrode at pilot.	Check for spark at electrode and pilot: if no spark and electrode wire is properly connected, replace igniter.
	Defective igniter (push-button)	Using a match, light pilot. If pilot lights, turn off pilot and push the red button again. If pilot will not light - check gap at electrode and pilot should be 1/8" to 1/4" to have a strong spark.
Pilot will not stay lit after carefully following lighting instructions.	Defective thermocouple (flame switch where applicable)	Check pilot flame. Must impinge on generator and thermocouple. Clean and/or adjust pilot for maximum flame impingement on generator and thermocouple. Replace thermocouple if pilot will not hold. (Hand tight 1/8 turn on replacement)
	Defective valve magnet.	Replace valve, if pilot won't hold after the thermocouple is replaced.
Pilot burning, no gas to burner, Valve knob "ON", Wall Switch "ON"	Wall switch or wires defective.	Check wall switch and wires for proper connections. Jumper wire across terminals at wall switch. If burner comes on, replace defective wall switch. If okay, jumper wires, across wall switch wires at valve. If burner comes on, wires are faulty or connections are bad.
	Generator may not be generating sufficient voltage.	Check generator with millivolt meter. Take reading at generator terminals of gas valve. Should read 325 millivolts minimum while holding valve knob depressed in pilot position and wall switch "off" Replace faulty generator if reading is below specified minimum.
	Plugged burner orifice.	Check burner orifice for stoppage and remove.
	Defective automatic valve operator.	Remove wall switch wires from gas valve. Install jumper wires from top and bottom terminals of gas valve. Turn valve on "ON". If main burner does not light, replace valve.
Frequent Pilot outage problem.	Pilot flame may be too low or blowing (high) causing the pilot safety to drop out.	Clean and/or adjust pilot flame for maximum flame impingement on generator and thermocouple.
Flame lifts off burner and goes out in less than 30 seconds	Inner 4" liner has come off flue or termination, flame is starving for oxygen	Attach 4" liner to flue or termination using screws, silicone and clamps as stated in manual
Flame lifts off burner on one side while the rest of the flame remains lit.	Improper installation of firebrick. Firebrick is likely leaning.	Be sure to position firebrick against firebox walls and be sure to use brick clips attached to the inner side of firebox.





## LIMITED LIFETIME WARRANTY

This Limited Lifetime Warranty applies only while the unit remains at the site of the original installation and only if the unit is installed inside the continental United States, Alaska, Hawaii, and Canada. The warranty applies only if the unit is installed and operated in accordance with the printed instructions and in compliance with applicable installation and building codes and good trade practices.

### BASIC ONE YEAR WARRANTY

During the first year after installation, we will provide a replacement for any component part of your unit found to be defective in materials or workmanship, including labour costs. Repair work requires prior approval by Kingsman, labour costs are based on a predetermined rate schedule and any repair work must be done through an authorized Kingsman dealer.

### LIMITED LIFETIME WARRANTY

The heat exchanger, combustion chamber and burner of every Kingsman product excluding the Outdoor Firepit are warranted against materials or workmanship during the period the product is owned by the original owner. The part to be replaced must be returned to our distributor in exchange for the replacement part. Any labor, material, freight and/or handling charges associated with any repair or replacement pursuant to this Limited Lifetime Warranty will not be covered by this warranty.

### GENERAL TERMS

In lieu of providing a replacement part, we may, at our option, provide the distributor's component purchase price from us or a credit equal to the distributors component purchase price from us toward the purchase of any new unit which we distribute. If a credit is given in lieu of a replacement part, the rating plate from the unit being replaced must be submitted on a warranty claim, and the unit being replaced must be made available to our distributor for disposition.

In establishing the date of installation for any purpose, including determination of the starting date for the term of this Limited Lifetime Warranty, reasonable proof of the original installation date must be presented\*, otherwise the effective date will be based upon the date of manufacture plus thirty (30) days.

We will not be responsible for and you, the user, will pay for: (a) damages caused by accident, abuse, negligence, misuse, riot, fire, flood, or Acts of God (b) damages caused by operating the unit where there is a corrosive atmosphere containing chlorine, fluorine, or any other damaging chemicals (other than in a normal residential environment) (c) damages caused by any unauthorized alteration or repair of the unit affecting its stability or performance (d) damages caused by improper matching or application of the unit or the unit's components (e) damages caused by failing to provide proper maintenance and service to the unit (f) any expenses incurred for erecting, disconnecting or dismantling the unit (g) parts or supplies used in connection with service or maintenance (h) damage repairs, inoperation or inefficiency resulting from faulty installation or application (i) electricity or fuel costs or any increase in electricity or fuel cost whatsoever including additional or unusual use of supplemental electric heat.

We shall not be liable for any incidental, consequential, or special damages or expenses in connection with any use or failure of this unit. We have not made and do not make any representation or warranty of fitness for a particular use or purpose, and there is no implied condition of fitness for a particular use or purpose. We make no express warranties except as stated in this Limited Lifetime Warranty. No one is authorized to change this Limited Lifetime Warranty or to create for us any other obligation or liability in connections with this unit. Any implied warranties shall last for one year after the original installation. Some states and provinces do not allow the exclusion or limitation of incidental or consequential damages or do not allow limitations on how long an implied warranty or condition lasts, so the above limitations or exclusions may not apply to you. The provisions of this limited warranty are in additions to and not a modification of or subtraction from any statutory warranties and other rights and remedies provided by law.

Save this certificate. It gives you specific legal rights, and you may also have other rights which may vary from state to state and province to province.

In the event your unit needs servicing, contact your dealer or contractor who installed or serviced your unit. When requesting service, please have the model and serial number from each unit readily available. If your dealer needs assistance, the distributor is available for support and we, in turn support the distributor's efforts.

Fill in the installation date and model and serial numbers of the unit in the space provided below and retain this limited warranty for your files.

Model No. \_\_\_\_\_ Serial No. \_\_\_\_\_ Date installed \_\_\_\_\_

Dealer or Contractor Name: \_\_\_\_\_

\*To receive advantage of your warranty, you must retain the original records that can establish the installation date of your unit.