



INSTALLATION AND OPERATION MANUAL

EPA CERTIFIED
CATALYTIC WOOD
BURNING FIREPLACE
INSERT



www.nficertified.org

We suggest that our wood-burning hearth products be installed and serviced by professionals who are certified in the U.S. by the National Fireplace Institute® (NFI) as NFI Woodburning Specialists or who are certified in Canada by Wood Energy Technical Training (WETT).



**Wood Energy
Technical Training**
www.wettinc.ca

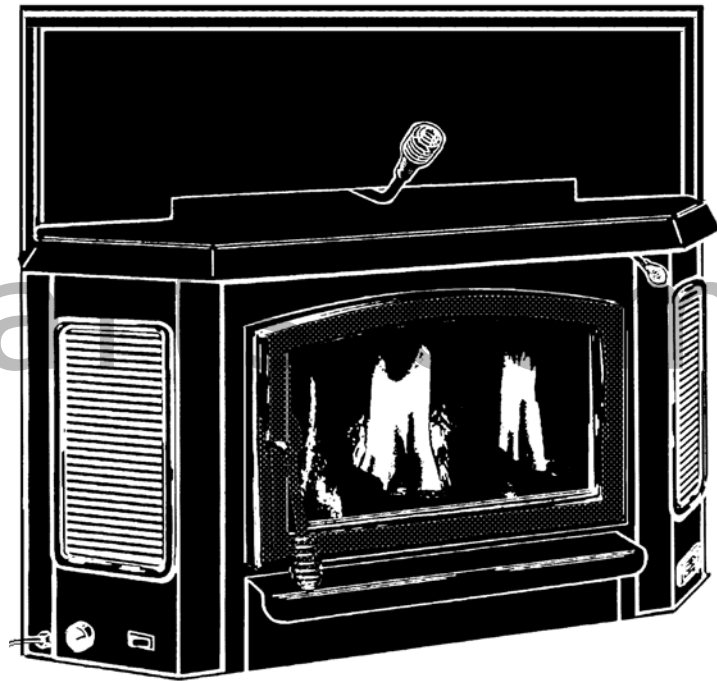

RETAIN THESE
INSTRUCTIONS
FOR FUTURE
REFERENCE

MODEL BV4000C-2

THIS APPLIANCE MUST BE INSTALLED BY A QUALIFIED INSTALLER.
READ ENTIRE MANUAL THOROUGHLY BEFORE INSTALLATION.

Tested &
Listed By  Beaverton
Oregon USA

OMNI-Test Laboratories, Inc.

P/N 775006M, Rev. M, 12/03

IMPORTANT WARNINGS

CAUTION: PLEASE READ THIS ENTIRE MANUAL BEFORE YOU INSTALL AND USE YOUR NEW ROOM HEATER. FOR YOUR SAFETY, FOLLOW THE INSTALLATION, OPERATION AND MAINTENANCE INSTRUCTIONS EXACTLY, WITHOUT DEVIATION. FAILURE TO FOLLOW THESE INSTRUCTIONS MAY RESULT IN PROPERTY DAMAGE, BODILY INJURY, OR EVEN DEATH. IF THIS APPLIANCE IS NOT PROPERLY INSTALLED, A HOUSE FIRE MAY RESULT. CONTACT YOUR LOCAL BUILDING OR FIRE OFFICIALS ABOUT RESTRICTIONS AND INSTALLATION INSPECTION REQUIREMENTS IN YOUR AREA.

1. If utilizing an older chimney, it must be inspected for adequate serviceability. Refer to the heading *Chimney Inspection* on page 6.
2. Install only in masonry fireplaces, built to UBC 37 or ULC S628 standards or A factory built fireplace (built to UL 127 or ULC S610 standards).
3. The minimum clearances must be maintained for all combustible surfaces and materials including; furniture, carpet, drapes, clothing, wood, papers, etc. Do not store firewood within this clearance space.
4. This appliance requires a non-combustible fireplace hearth or hearth extension (see *Floor Protection* on page 4 for additional information).
5. Minimum ceiling height must be 7 feet (213 cm) (measured from base of appliance to ceiling).
6. **DO NOT CONNECT THIS UNIT TO A CHIMNEY FLUE CONNECTED TO ANOTHER APPLIANCE.**
7. Do not connect this appliance to air ducts or any air distribution system.
8. Do not install appliance in a sleeping room.
9. **PREVENT CREOSOTE FIRE:** Inspect and clean chimney frequently. Under certain conditions of use, creosote buildup may occur rapidly. Inspect chimney connector and chimney twice monthly and clean if necessary. Using green or inadequately seasoned wood can greatly increase creosote buildup. Use dry wood to minimize creosote buildup.
10. **USE SOLID WOOD FUEL ONLY:** This appliance is approved for burning dry seasoned natural wood only. **CAUTION: BURN UNTREATED WOOD ONLY. DO NOT BURN GARBAGE OR FLAMMABLE FLUIDS SUCH AS GASOLINE, NAPHTHA OR ENGINE OIL.**
11. Never use gasoline, gasoline-type lantern fuel, kerosene, charcoal lighter fluid, or similar liquids to start or "freshen up" a fire in this heater. Keep all such liquids well away from the heater while it is in use.
12. **DO NOT OVERFIRE:** If heater or chimney connector glows, you are overfiring. Overfiring this appliance could cause a house fire. Overfiring is a condition where the appliance is operated at temperatures above its design capabilities (see *Overfiring*, on page 21). Overfiring can be caused by improper installation, improper operation, lack of maintenance or improper fuel usage. Damage caused from overfiring is NOT covered under the manufacturers limited warranty (see *Care and Operation*, pages 13 to 16).
13. **NEVER LEAVE AN UNATTENDED FIREPLACE INSERT BURNING ON HIGH.** Operation of the fireplace insert with the primary air control at its highest burn rate setting for extended periods can cause dangerous overfiring conditions. The primary air control should only be positioned at the highest setting during start-up procedures and for short durations. When leaving the fireplace insert unattended ensure that the primary air control is set to the low or medium low range.
14. Use a metal container with a tight fitting lid to dispose of ashes.
15. **IN THE EVENT OF A COMPONENT FAILURE, USE ONLY COMPONENTS PROVIDED BY THE MANUFACTURER AS REPLACEMENT PARTS.**
16. Burning any kind of fuel uses oxygen from the dwelling. Be sure that you allow an adequate source of fresh air into the room where the fireplace insert is operating (see *Ventilation* on page 5).
17. **CAUTION: HOT WHILE IN OPERATION.** An appliance hot enough to warm your home can severely burn anyone touching it. Keep children, clothing and furniture away. Contact may cause skin burns. Do not let children touch the appliance. Train them to stay a safe distance from the unit.
18. Build fires directly upon the brick hearth inside the fireplace insert. Do not use grates, irons or any other method to elevate the fire.
19. Once the fire is established, never burn the appliance with the bypass damper open, except when refueling the appliance.
20. **CATALYTIC COMBUSTOR:** Do not operate this appliance without the catalytic combustor assembly (this consists of ceramics, gasket and a housing) properly installed. Burning of metal foils, coal, plastic garbage, diesel oil and sulfur will make the catalyst in the combustor inactive. The combustor is fragile; handle carefully. The performance of the catalytic device or its durability has not been evaluated as part of the certification.
21. See the listing label located on the back of fireplace (or see *Safety/Listing Label* on page 27).
22. **SAVE THESE INSTRUCTIONS.**

TABLE OF CONTENTS

Important Warnings	2
Testing / Listing, EPA, Using this Manual.....	3
Planning Your Installation	4-7
Installation	8-11
Product Features and Controls	12
Care and Operation	13-16
Recommended Fuel	16
Maintenance	17-19
Troubleshooting	20-21
Specifications.....	22
Replacement Parts List.....	23-25
Optional Accessories	26
Safety / Listing Label	27
EPA Label.....	28
Service / Maintenance Log	29

TESTING/LISTING

Model BV4000C-2 has been tested to UL Standards UL1482, ULC-S627 for installation into residential applications. The listing laboratory is OMNI Test Laboratories, Inc.; Beaverton, Oregon; Report # 030-S-05-2.

EPA CERTIFICATION

This fireplace insert has been tested to rigorous emissions standard, and has been certified by the Environmental Protection Agency.

USING THIS MANUAL

Please read and carefully follow all of the instructions found in this manual. Please pay special attention to the safety instructions provided in this manual. The Homeowner's Care and Operation Instructions included here will assure you have many years of dependable and enjoyable service from your appliance.

CONGRATULATIONS ON THE PURCHASE OF YOUR NEW WOOD BURNING FIREPLACE INSERT MANUFACTURED BY LENNOX HEARTH PRODUCTS.

When you purchased your new insert, you joined the ranks of thousands of concerned individuals whose answer to their home heating needs reflects their concern for aesthetics, efficiency and our environment. We extend our continued support to help you achieve the maximum benefit and enjoyment available from your new insert.

It is our goal at Lennox Hearth Products to provide you, our valued customer, with an appliance that will ensure you years of trouble free warmth and pleasure.

Thank you for selecting a Lennox Hearth Products insert as the answer to your home heating needs.

**Sincerely,
All of us at Lennox Hearth Products**

INSERT PACKAGING LIST

This appliance is packaged with an accessory package, which contains the following:

- One - Installation and operation instructions manual.
- One - Warranty
- One - Catalytic combustor temperature probe and sleeve.
- One - Damper Hook

SURROUND KIT PACKAGING LIST (PURCHASED SEPARATELY)

- One - Surround Top Panel
- Two - Surround Side Panels
- One - Insulation Set (2 side panel blankets and 1 top panel blanket)
- One - Surround Trim Set (2 side trims and one top trim)
- Two - Corner keys ("L" shaped surround trim brackets)
- Four - Screws, #8-32 x 3/8" Phillips
- Four - Nuts, #8-32 KEP

PLANNING YOUR INSTALLATION

QUESTIONS TO ASK LOCAL BUILDING OFFICIAL

A correct installation is critical and imperative for reducing fire hazards and perilous conditions that can arise when wood burning appliances are improperly installed. The installer must follow all of the manufacturers' instructions.

The installation of a wood burning appliance must conform to local codes and applicable state and federal requirements. Familiarity with these requirements before installation is essential. Important considerations to discuss with local building officials include:

1. Applicable codes (i.e. Uniform Mechanical Code, State or Regional Codes).

Electrical codes: The blower system has a flexible electrical cord that must be electrically grounded per local codes or per electrical codes:

In USA, NEC, ANSI/NFPA 70-2002.

In Canada, CSA C22.1

WARNING: ELECTRICAL GROUNDING INSTRUCTIONS: THIS APPLIANCE IS EQUIPPED WITH A THREE-PRONG (GROUNDING) PLUG FOR YOUR PROTECTION AGAINST SHOCK HAZARD AND SHOULD BE PLUGGED DIRECTLY INTO A PROPERLY GROUNDED THREE-PRONG RECEPTACLE. DO NOT CUT OR REMOVE THE GROUNDING PRONG FROM THIS PLUG. DO NOT ROUTE POWER CORD UNDER OR IN FRONT OF APPLIANCE.

2. Local amendments?
3. Is a permit required - cost?
(You may wish to contact your insurance company to ask if they require this).
4. Rooms where the installation is not allowed?

SMOKE DETECTORS

Since there are always several potential sources of fire in any home, we recommend installing smoke detectors. If possible, install the smoke detector in a hallway adjacent to the room (to reduce the possibility of occasional false activation from the heat produced by the fireplace insert). If your local code requires a smoke detector be installed within the same room, you must follow the requirements of your local code. Check with your local building department for requirements in your area.

IMPORTANT – THIS APPLIANCE IS NOT APPROVED FOR INSTALLATION INTO A MANUFACTURED (MOBILE) HOME IN CANADA OR IN THE USA.

FLOOR PROTECTION

This appliance requires a heat resistant non-combustible approved fireplace hearth or hearth extension. If a hearth extension is used it must be a 3/8" (minimum) noncombustible material or equivalent. If the floor protection is to be stone, tile, brick, etc., it must be mortared or grouted to form a continuous non-combustible.

USA - This protected area must extend a minimum of 16" to the front of the fuel door opening and 8" beyond both sides of the fuel door opening.

Canada - This protected area must extend a minimum of 18" to the front of the fuel door opening and 8" beyond both sides.

HEARTH PROTECTION

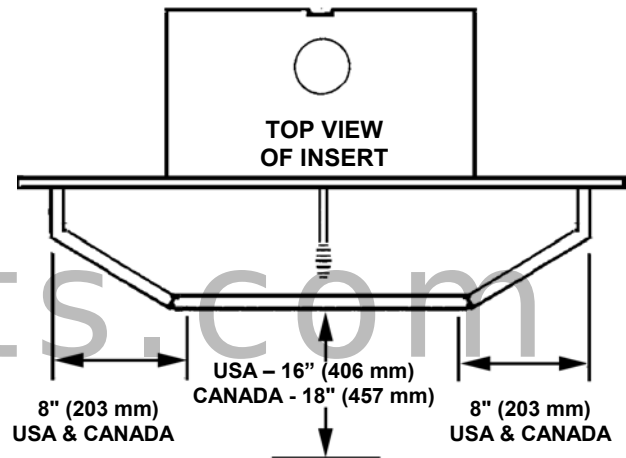

CHIMNEY INSPECTION

The existing fireplace should be inspected by a local fire marshal or qualified installer for adequate serviceability prior to installing this appliance.

Factory built fireplace: If any portion of the chimney system shows signs of structural or mechanical weaknesses, such as: cracks, leaky joints, corroded or warped surfaces. Look for obvious bulges in the lining, which may indicate the need to replace that section (use a bright flashlight. Any faulty portion must be repaired or replaced prior to installing this appliance. Also, inspect the attic to see that the chimney has proper clearance to combustible framing members.

Masonry fireplace: The chimney should have no cracks, loose mortar, other signs of deterioration, or blockage. Any necessary repairs should be done by a qualified mason.

If the existing fireplace flue system is dirty or has some obstruction in it, clean it. A dirty chimney can cause your insert to smoke when refueling, and can result in a chimney fire. An oversized chimney may result in less than optimum performance. Installations into a large masonry chimney may require a liner to improve performance.

PLANNING YOUR INSTALLATION

CLEARANCES

WARNING: IT IS VERY IMPORTANT THAT YOU OBSERVE THE MINIMUM CLEARANCES. DO NOT STORE FIREWOOD WITHIN THIS CLEARANCE SPACE. FAILURE TO MAINTAIN CLEARANCES TO ALL COMBUSTIBLES MAY RESULT IN A HOUSE FIRE.

There are listed clearances for your fireplace insert which were determined in a laboratory testing and must be maintained.

Minimum Clearance to Combustibles

Stove top to mantel:	32" / 813 mm
Stove top to trim:	24" / 610 mm
Stove side to trim:	9" / 229 mm
Stove side to sidewall:	17" / 432 mm

Side View of Insert

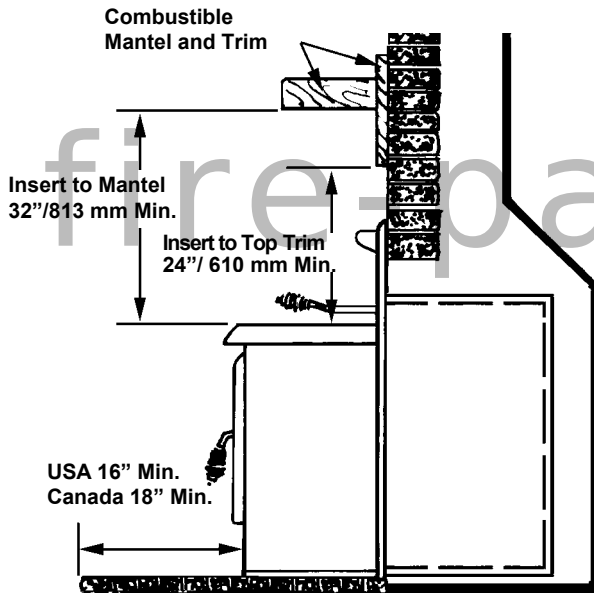

Top View of Insert

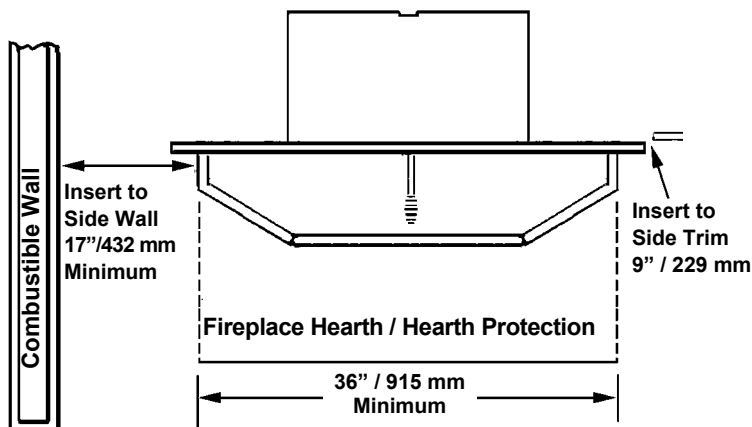

DRAFT REQUIREMENTS

The appliance is merely one component of a larger system. The other equally important component is the venting system. This is necessary for achieving the required flow of combustion air to the fire chamber and for safely removing unwanted combustion byproducts from the appliance. If the venting system's design does not promote these ends, the system may not function properly. Poorly functioning venting systems may create performance problems as well as be a safety hazard (i.e. an oversized chimney may result in less than optimum performance. Installations into a large, masonry chimney may require a liner to improve performance). A draft gauge should read between .05 and .07 inches W.C. (water column.).

PROVIDE ADEQUATE AIR FOR COMBUSTION

In well insulated and weather tight homes, it may be difficult to establish a good draft up your chimney. The poor draft is caused by a shortage of air in the house. To provide the needed air, crack a window on the windward side of the house.

VENTILATION REQUIREMENTS

THE FRESH AIR REQUIREMENTS OF THIS APPLIANCE MUST BE MET WITHIN THE SPACE WHERE IT WILL BE INSTALLED.

Ventilation is essential when using a solid fuel burning heater. The combustion process of this heater uses oxygen from inside the dwelling and it may be necessary to open a window or install a vent to provide make-up air into a dwelling that is well insulated (modern construction standards have resulted in homes that are highly energy-efficient and that allow little heat loss and air transfer). Other appliances in the dwelling also contribute to removing air from the dwelling (i.e. clothes dryers, exhaust fans, fireplaces, and other fuel burning appliances). If the available fresh air delivery in the dwelling is insufficient to support the demands of these appliances, problems can result (i.e. excessive negative pressure can develop in the dwelling which will affect the rate at which this appliance can draft. See *Draft Requirements* on this page).

PLANNING YOUR INSTALLATION

FACTORY BUILT FIREPLACES

(Not Approved In Canada)

In the USA, this appliance is approved for installation into a listed factory built solid fuel burning fireplace (built to UL 127 or ULC S610 standards). The fireplace firebox must accept the insert without modification other than removing bolted or screwed together pieces such as smoke shelf/deflectors, ash lips, screen or door tracks and damper assemblies, that must be reinstalled to restore the fireplace to its original operating condition if the insert is removed and not replaced. The removal of any part must not alter the integrity or outer shell of the pre-engineered fireplace cabinet in any way.

Venting Requirements for factory built fireplace:

The fireplace damper must be secured in the open position. This appliance requires the use of a 6" (152 mm) diameter flex or rigid, UL1777 listed 2100° HT liner or equivalent. The liner must extend from the flue outlet of the appliance to termination. Do not face seal over fireplace chimney cooling air systems. Offsets can be handled with an offset adapter (it aligns starter pipe with fireplace flue). For more information on the offset adapter, see pages 9 and 25.

WARNING: DO NOT SUBSTITUTE THE HEAT RATED 2100°HT LINER WITH ANY OTHER TYPE LINE OR A FIRE MAY RESULT CAUSING PROPERTY DAMAGE, PERSONAL INJURY OR LOSS OF LIFE.

Factory Built Fireplace Installation

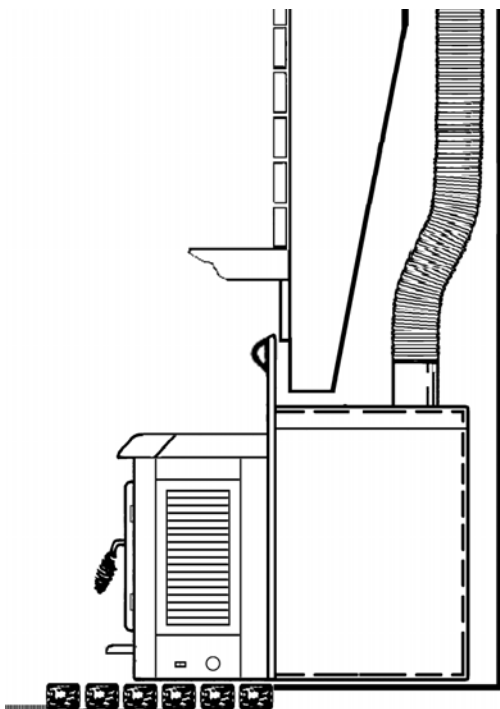

MASONRY FIREPLACES

Note: Measure fireplace size to make certain the insert will fit before considering the installation.

This appliance is approved for installation into a masonry fireplace built to UBC 37 or ULC S628 standards. Do not remove brick or mortar from the masonry fireplace to accommodate this appliance.

IMPORTANT: Any opening between the masonry of the fireplace and the facing masonry must be permanently sealed.

USA Requirements / Masonry Fireplaces - The fireplace damper must be secured in the open position. In the USA, a flue extension past the fireplace header is required as a minimum. A preferred installation is a positive flue connection (sealing the throat of the chimney). This appliance requires the use of a 6" (152 mm) diameter flex or rigid single wall pipe, minimum 24 / 25 MSG black or blued steel connector pipe (stainless steel recommended).

Canada Requirements / Masonry Fireplaces - - This fireplace insert must be installed into an approved solid fuel Masonry fireplace only (installation into a factory built fireplace is not approved). The fireplace damper must be secured in the open position. The fireplace insert must be installed with a continuous chimney liner of 6" / 152 mm diameter extending from the fireplace insert to the top of the chimney. The chimney liner must conform to the Class 3 requirements of CAN / ULC – S635, Standard for Lining Systems for Existing Masonry or Factory-Built Chimneys and Vents, or CAN / ULC – S640 Standard for Lining Systems for New Masonry Chimneys.

PLANNING YOUR INSTALLATION

OFFSETS

Offsets can be handled with an offset adapter (it aligns flue outlet of appliance with fireplace flue). For more information on the offset adapter, see pages 9 and 25.

FIREPLACE CHIMNEY MAXIMUM SIZE TO ENSURE PROPER DRAFT – USA ONLY

Note: Installations in Canada require a full-length liner.

The fireplace insert flue size is 6 inches (152 mm) diameter, which is approximately 28 square inches (711 square mm), the minimum. The maximum flue size should be no more than (3) three times the cross sectional area of the size of the fireplace insert flue collar. In this case, that would be no larger than a 10 inch (254 mm) diameter stack (area = approx. 85 sq. inches [216 sq. cm]).

Note: Formulas for calculating Area:

Calculating area of a circle:

$$\pi \times r^2 = \text{Area} \quad (\pi = 3.1416, r = 1/2 \text{ diameter})$$

To calculate area of square or rectangle:

$$\text{Width} \times \text{Depth} = \text{Area}$$

Notes:

- **It may be necessary to use a full-length liner to achieve adequate draft for the appliance. A draft gauge should .05" W.C., to .07" W.C. for optimum performance.**
- **This appliance is approved for all heatform style fireplaces (masonry fireplace with a metal fire-box liner).**

fire-parts.com

INSTALLATION

FIREPLACE INSTALLATION

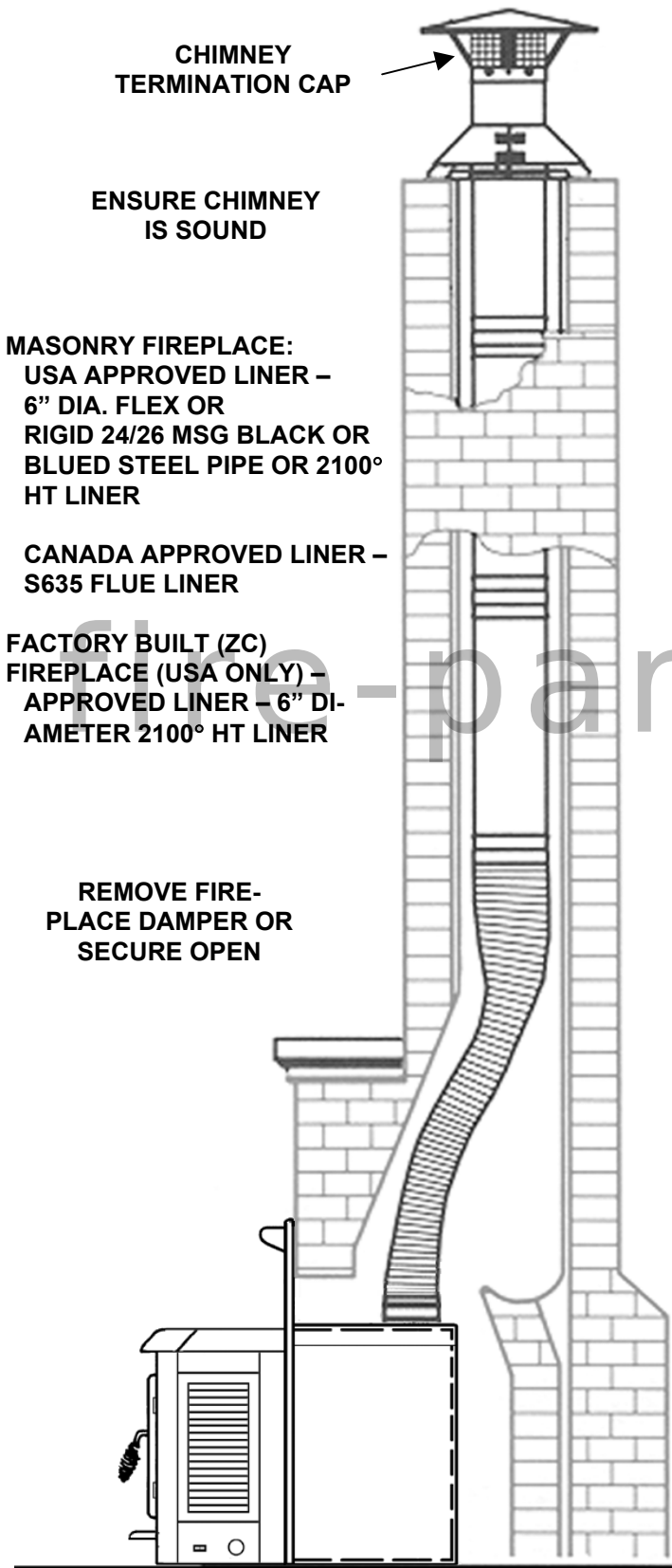

- USA only - All masonry fireplace installations require a minimum positive flue connection using a block-off plate or a positive seal past the bottom of the chimney flue tile liner. In Canada, a full reline is required.
- Measure fireplace size to make certain the insert will fit before considering the installation.

MINIMUM FIREBOX DIMENSIONS

Note: Measure fireplace size to make certain the insert will fit before considering the installation.

Minimum size required for fireplace firebox (recessed area into fireplace):

Height	21" / 533 mm
Width	22 1/2" / 572 mm
Depth	16" / 406 mm

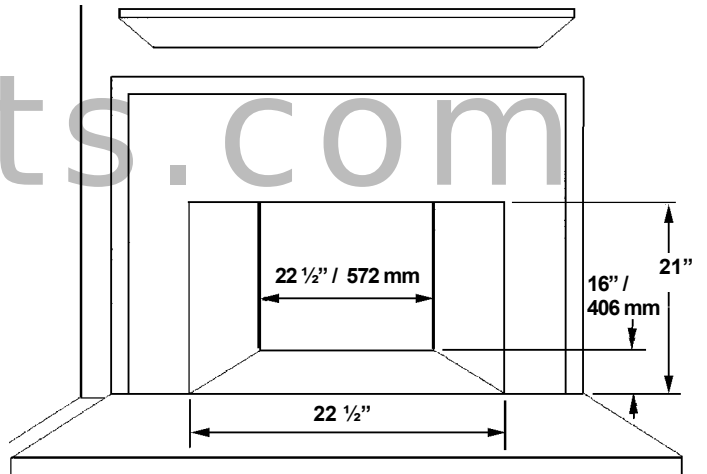

INSTALLATION

CATALYTIC TEMPERATURE PROBE

Install temperature probe prior to installing insert.

To install the *Catalytic Temperature Probe* locate the plug on the top, right-hand side of the bypass control rod. Remove the plug, install the sleeve, and place probe in sleeve. It may be necessary to bend the flange on the plug so it won't interfere with the probe temperature indicator.

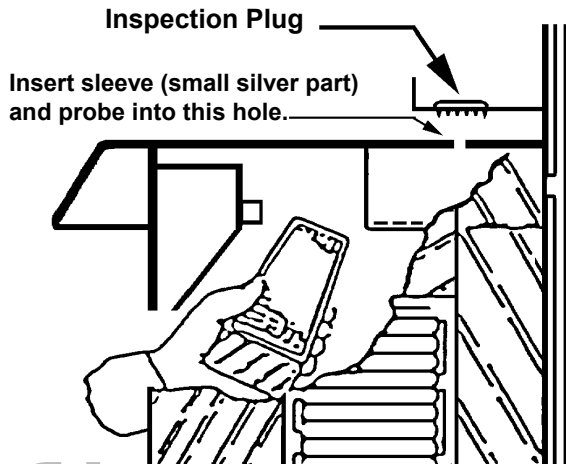

The Catalytic Temperature Probe is provided so you can monitor the temperature of your Catalytic Combustor. Once you have established a fire and the Catalytic Temperature Probe indicates the temperature of your Catalytic Combustor is between 500° - 600° F (approximately 20 - 25 minutes) close the Bypass Damper Control. Depending on the type and size of the fuel load as well as the length of time the stove has been burning, your Catalytic Combustor should operate between 1000 - 1800° F.

POWER CORD CHANGEOVER

The power cord which is positioned on the left side of the insert (as viewed while facing unit), can be relocated to the right side, using an optional *Cord Changeover Kit* (See Cat. No. 14M73, on page 29).

INSTALLATION STEPS

1. Remove all ashes from the fireplace.
2. Remove all materials inside the insert and set them aside.
3. Remove the three-piece surround assembly (purchased separately) and attach insulation material provided using a nonflammable adhesive (i.e. RTV High Temperature Silicone, rated 570° F).
4. Use a large piece of cardboard or other protective material and place it in front of the fireplace to protect floor or carpet during installation.
5. Remove the insert from its wood pallet by removing the screws.

6. Prepare chimney connection system as specified for masonry or factory built fireplaces.
7. Set the insert on the protective cardboard laid out in front of the fireplace centered in front of the fireplace opening.
8. (Masonry Fireplace) Slide insert into the fireplace far enough to attach the starter pipe or positive flue connection (a minimum of a 6" starter pipe extending past the header is required). See * note.
9. (Factory Built Fireplace) Slide insert into the fireplace far enough to attach connector to flue outlet. See * note.
10. Offsets can be handled using an offset adapter (it aligns starter pipe with flue. See *Offset Adapter*, page 25 for ordering information). Do not push insert in completely until surround assembly is installed. Care should be used to ensure that this adjustable connector is oriented so it does not angle downhill when positioned on the flue outlet on top of insert.

Once offset is leveled and aligned to the vent pipe, the offset must be sealed with high temperature sealant.

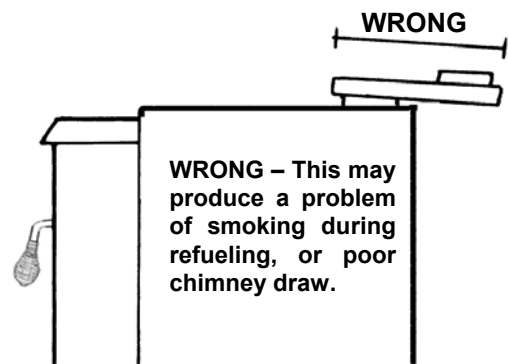
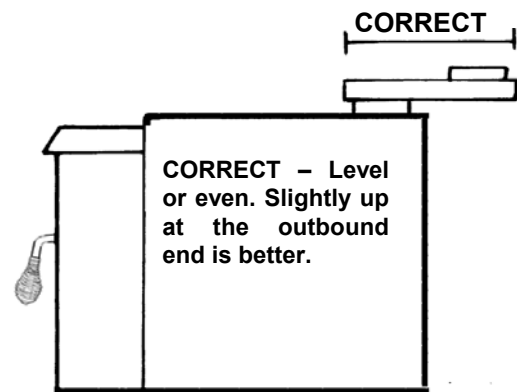

INSTALLATION

11. If the floor of the fireplace is lower than the hearth, a leveling bolt will need to be installed (not included with the hardware. Use a 3/8" (10 mm) bolt with 2 nuts). The bolt length should be at least 1" (25.4 mm) longer than needed. Locate the leveling bolt bracket on the lower back of insert. Install the leveling bolt with nuts and adjust length as needed.

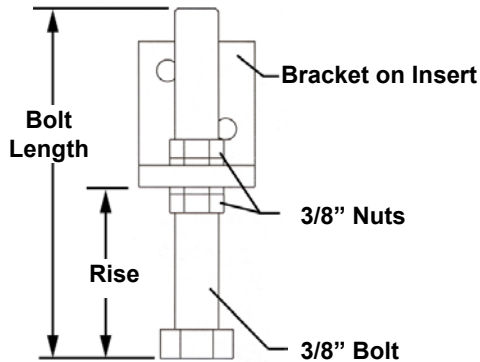

Example: If rise needed is 2" / 51 mm, use a 3" / 75 mm or larger bolt.

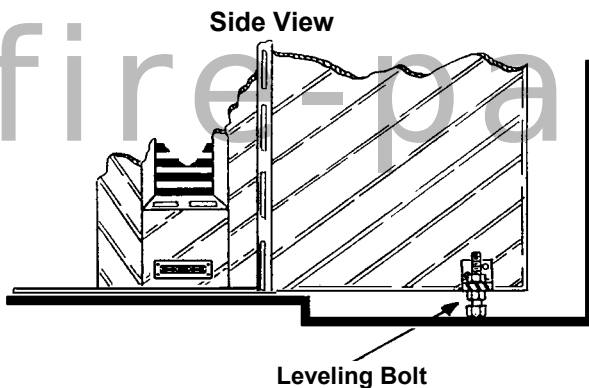

12. Reaching over the top of the insert, install the starter pipe in the stove flue, or attach the positive flue connection to the insert. See * Note.

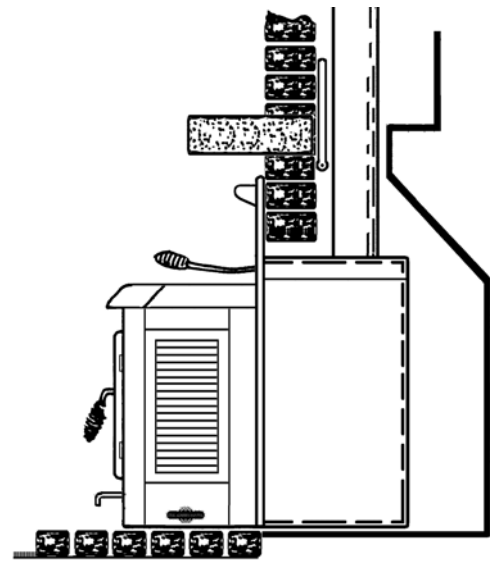
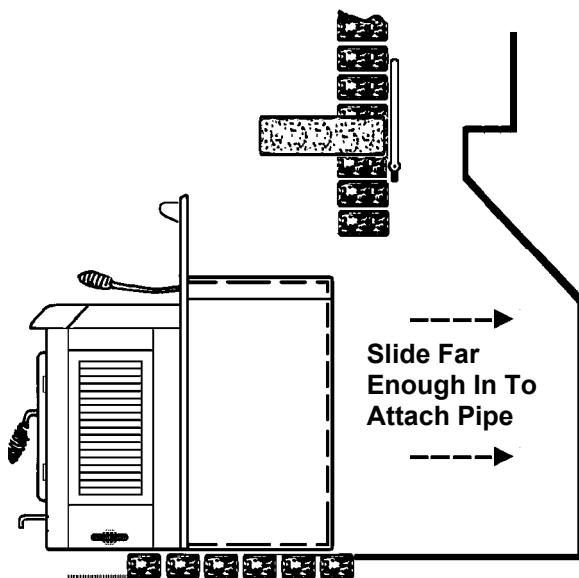

SURROUND ASSEMBLY (PURCHASED SEPARATELY)
NOTE: Do not face seal over chimney cooling air system on superior brand or any brand fireplace which is designed with the chimney cooling air system.

13. Pull the insert slightly forward to its desired position; attach the face shield using the surround clips and hardware as shown. The fiberglass insulation strips should be secured along the top and sides (step 3). Assemble the gold-tone trim using the 2 inside corner brackets. Attach trim to the face shield and stove.

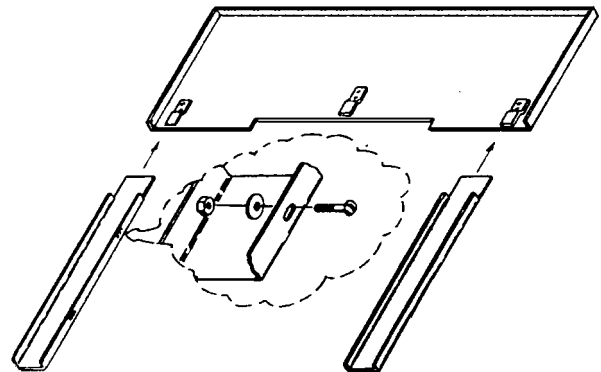

Heat Deflector Must Be Installed If There is a Mantel

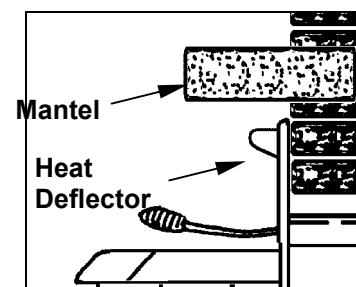

INSTALLATION

14. Push the unit back until face shield insulation is compressed against the fireplace front, forming a tight seal. **Test for air leaks by holding a candle around edge of face shield to see if smoke is pulled into fireplace.**

* Note: Preferred method of attaching connector to flue outlet is to install two L-Brackets (1" angle bracket, 3/4" wide) on opposite sides of the flue outlet: Use self-tapping screws to secure in place. Cut a 1/2" (height) and 3/4" (width) notch in the front of connector (pipe, liner or adapter that will attach to flue outlet). Install connector into flue outlet and secure to angle brackets using machine screws. Seal around connection with furnace cement.

POSITIVE FLUE CONNECTION FOR MASONRY FIREPLACE

A Professional should inspect chimney prior to installation to determine if any repairs are necessary or if a chimney reline is necessary.

The fireplace damper must be secured in the open position. If this is not possible, it will be necessary to remove the damper. Installation into a masonry fireplace requires as a minimum of a flue extension past the header. This can be accomplished by one of the following methods:

Install 6" smoke pipe if the chimney is located directly above the insert flue

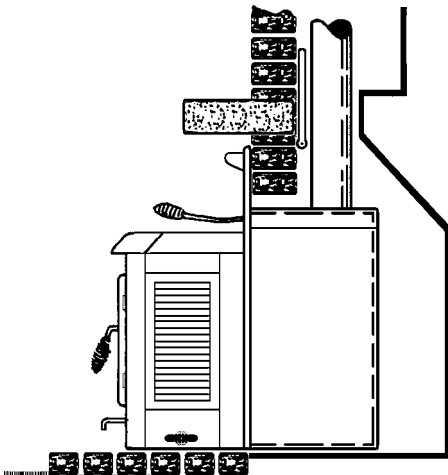

(Or) Install 6" flex pipe to achieve the same result.

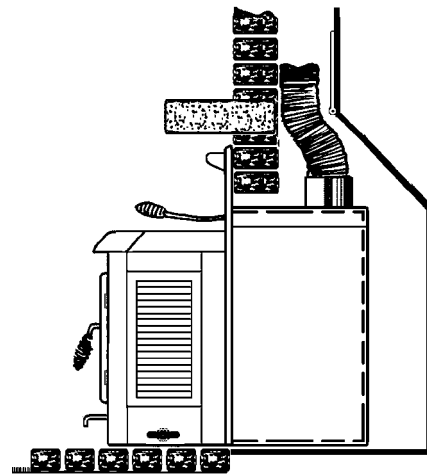

Use an offset adapter (see page 25) to handle offsets. This part is available through your dealer.

A preferable installation is the positive flue connection (a positive seal between the flue extension and the chimney). This can be achieved by using a filler plate. A filler plate can be made by making a cardboard pattern to fit the fireplace throat. Lay the pattern on 22 gage steel, add 2 inches to each side, and cut. Snip corners and bend front lip up and sides and back down. Cut an opening for the flue extension and secure with masonry screws.

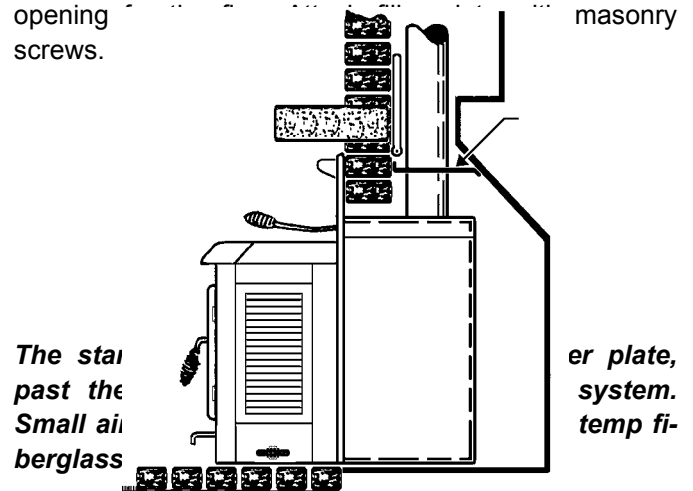

The stainless steel flue extension must extend past the fireplace opening.

Filler plate, system. temp fireproof.

FILLER PLATE

PRODUCT FEATURES AND CONTROLS

ASH DRAWER

The large ash drawer located below the fuel door is designed to make cleaning easier by containing the ashes in a removable drawer.

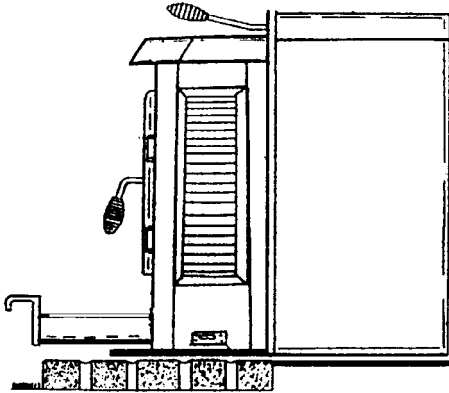

CAUTION: DO NOT OPERATE THE STOVE WITH THE ASH DUMP COVER OFF, AS THIS WILL PRODUCE EXTREME TEMPERATURES WITHIN THE STOVE (OVER-FIRING) AND COULD CAUSE DAMAGE TO THE APPLIANCE OR OTHER PROPERTY (SUCH DAMAGE IS NOT COVERED BY THE MANUFACTURERS WARRANTY). REPLACE THE ASH DUMP GASKET IF IT BECOMES FRAYED OR DAMAGED.

BLOWER SYSTEM

The 250-CFM room air circulation blower system comes equipped with a variable speed control (rheostat). The blower system can be operated manually or set to operated automatically (so the blowers will turn on when the insert is hot and turn off when the insert is cool). See Care and Operation Section – *Blower System* on page 15.

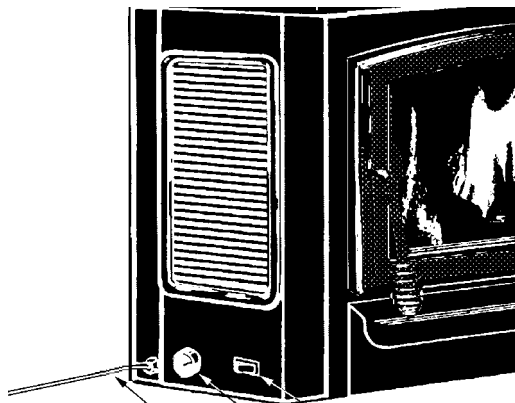

POWER CORD

RHEOSTAT (SPEED CONTROL)

ON/OFF SWITCH (AUTO OR MANUAL MODE)

PRIMARY AIR CONTROL

The primary combustion air delivery is controlled by the primary air control draft module (The control handle is located above the fuel door). The heat output can be controlled by sliding the handle to a higher or lower heat output setting (see following illustrations). The fuel, the amount of heat and burn times desired, the type of installation are all variables that will affect the control setting. The same control settings in a variety of installations will produce different results. You will need to try different settings so you can learn how much heat to expect and how long the fire will burn.

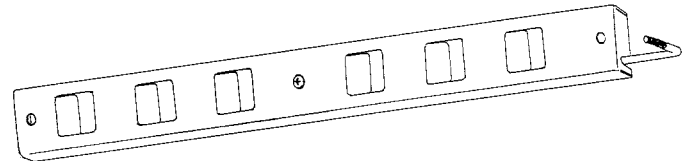

← Lower Higher →

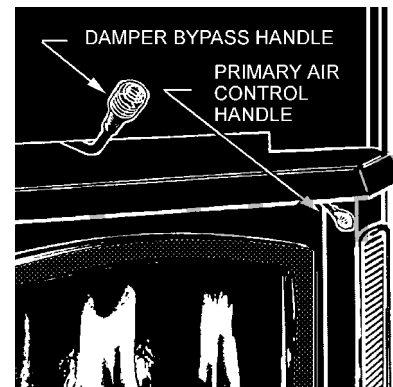

CATALYTIC BYPASS DAMPER CONTROL

The bypass damper control handle is located on the front of the insert (see above illustration). By pushing in or pulling out the handle, the operator can route the exhaust either through the catalytic combustor (pushed in) or directly up the flue (pulled out). When starting a fire or refueling, the handle must be pulled out. Once the fire is established it must be pushed in.

CATALYTIC COMBUSTOR

How it works: From 5 to 30 percent of the chemical energy contained in every log escapes up the chimney when wood is burned in a conventional stove. The catalytic combustor is designed to make use of this energy, converting it into useful heat as it lessens chimney creosote build-up and air pollution. The catalytic combustor consists of a durable temperature resistant ceramic composition, which is extruded into a cellular, or honeycomb, configuration. After extrusion, this ceramic monolith is fired and then covered with a noble-metal catalyst. When wood smoke contacts this catalyst, chemical changes occur that causes the smoke to ignite at temperatures around 600° F. Normally, smoke will ignite and burn only at temperatures around 1000° F.

CARE AND OPERATION

FUEL DOOR

CAUTION: WHEN OPENING THE DOOR, DO NOT EXTEND IT BEYOND ITS NORMAL TRAVEL. OVEREXTENDING THE DOOR TO A FURTHER OPEN POSITION CAN PUT EXCESSIVE STRESS ON HINGE AREA OF DOOR AND HINGE PINS AND MAY RESULT IN BREAKAGE.

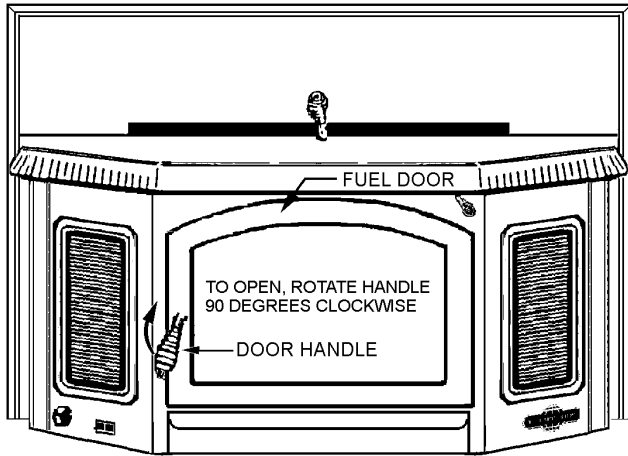

Gold Doors (If optional gold door is purchased. See page 26 for ordering information): Gold doors are plated with 24-karat industrial grade gold and will require curing to harden the gold. Once it is cured it will never tarnish. Prior to burning this appliance the doorframe should be cleaned thoroughly with a good window cleaning solution and a soft cloth. Do not use any metal polishes or abrasives to clean the gold surface. Any oils or fingerprints left on the gold could become permanent blemishes if the stove is burned prior to their removal. After the first few fires, the gold will cure. The $\frac{3}{4}$ " (19 mm) door rope gasket is made of highly durable high temperature resistant material. It must be kept in good condition. Do not leave the stove burning with the door ajar or open. Leaving the door ajar or open while the stove is burning will cause excessive heat build up in the stove (overfiring) and could ignite surrounding combustibles as well as damage the stove (such damage is not covered by the manufacturers warranty).

DOOR HANDLE ASSEMBLY

The door handle assembly opens and securely latches the fuel door closed. To open the door, rotate the coil handle to the 9:00 position until door releases. To close and latch, hold the coil handle in the 9:00 position, close the door, then rotate the handle to the 6:00 position. See illustration above.

GLASS

The Glass is a super heat resistant ceramic that withstands continuous temperatures up to 1390° F. This temperature is well beyond the temperatures in which you operate your fireplace insert.

This unit is designed to provide a flow of air over the inside of the glass, where along with high heat helps keep it clean. When operating the fireplace insert on low for extended periods of time, the glass may get dirty. A short, hot fire (15 - 20 minutes) will help clean off much of the normal buildup (see *Troubleshooting*). A commercial glass cleaner designed for fireplace inserts is recommended for cleaning.

The glass should be cleaned thoroughly with glass cleaner and a soft cloth BEFORE the fireplace insert is burned.

DOOR GASKET

The door gasket must be kept in good condition. Do not leave the stove burning with the door ajar or open. Leaving the door ajar or open while the stove is burning will cause excessive heat build up in the stove (overfiring) and could ignite surrounding combustibles as well as damage the stove (such damage is not covered by the manufacturers warranty).

USE CONTROL SETTINGS THAT WORK FOR YOU

The fuel, the amount of heat you want, the type of installation you have and how long you wish the fire to burn are all variables that will affect the control setting. The same control settings in a variety of installations will produce different results.

Familiarize yourself with your fireplace insert by trying different settings so you can learn how much heat to expect and how long the fire will burn. It may take a week or two to learn but your patience will be rewarded by the warmth and pleasant satisfaction that only a wood fire can provide.

CARE AND OPERATION

BREAK-IN PERIOD

Your fireplace insert finish is a high temperature paint that requires time and temperature to completely cure. We recommend that you ventilate the house during the initial burns. The paint emits non-toxic odors during this process.

KEEP YOUR HOUSE WELL VENTILATED DURING THE CURING PROCESS TO PREVENT ACTIVATION OF YOUR HOME SMOKE DETECTOR.

The paint manufacturer recommends three burn cycles to cure the paint. The first two burns should be low heat, approximately 250°F., for 20 minutes each, using paper and light kindling.

After each 20-minute burn, allow the appliance to cool completely. The third burn should be at least medium high or about 450°F. for 45 - 60 minutes. The paint will become soft and emit non-toxic haze during these burns. Keep the area well ventilated.

As the paint cures it will become slightly lighter in color. Eventually the entire surface will become an even color. Once the paint has been softened and cooled two or three times, it will harden. Do not turn on a blower during the curing process. Do not place anything on the fireplace insert surface until the paint is completely cured. Do not attempt to repaint the fireplace insert until the paint is completely cured. If the surface later becomes stained or marred, it may be lightly sanded and touched up with spray paint from the same paint manufacturer (See *Maintenance* – Small Area Paint Touch-up). Paint is available at your local authorized Lennox Hearth Products dealer. Never attempt to paint a hot stove.

CATALYTIC COMBUSTOR

During the start-up of a cold stove, a medium to high firing rate must be maintained for about 20 minutes. The high firing rate will ensure that the stove, the flue, the catalyst, and the fuel are all stabilized at proper operating temperatures. Even though it's possible to have temperatures in the stove reach 600°F. within two or three minutes after the fire is started, do not set the primary air control lever to the "LOW" position until approximately twenty minutes have passed. Setting the primary air control on "LOW" too early could result in either the fire or the catalytic combustor going out.

At the end of a burn cycle, it's possible that the hot embers remaining might not provide sufficient fuel value for the catalyst to retain its minimum operating temperature of 600°F. During the refueling, we recommend that the stove be refired for about 10 minutes with the bypass open to ensure a good draw is established and that the catalyst reaches 600° F. The refiring will ensure sufficient temperatures and proper amounts of volatiles for the catalyst to operate properly.

When refueling a hot stove with the catalyst still operating, no refiring step is necessary. Just open the bypass, set the primary air control to high, open the door approximately 1/2 inch, and wait for about thirty seconds. Load the fuel, close the door, close the bypass and set the primary air control to normal operation. Temperatures within the fire-box should be hot enough to maintain the catalytic operation.

HOW TO START AND MAINTAIN A FIRE

1. Check to ensure the ash dump cover (in center of fire-box floor) is in place and the ash drawer is closed.
2. Open the bypass damper control by pulling it out (toward you). In the "OPEN" position the draft air will bypass the catalytic combustor and make starting the fire easier.
3. Set the primary air control lever on "HIGH". The "HIGH" setting will maximize your primary combustion air.
4. Build a fire directly on the firebrick covering the bottom of the stove.
 - a. Place five or six loosely crumpled sheets of newspaper in the stove.
 - b. Add a small amount of dry kindling randomly on the top of the newspaper.
 - c. Place a few more loosely crumpled newspapers on top of the kindling and light the bottom paper first, then light the top paper. Once the kindling is ignited and burning on its own, close the fuel door. The upper fire should help preheat the chimney and create an effective draft while the lower fire ignites the kindling.
5. When the kindling is burning well, add increasingly larger pieces of wood until the fire is actively burning.
6. When the fire is well established, use the damper hook and close the bypass by pushing the control rod in (catalytic temperature probe should read 500-600°F, takes approximately 20 - 25 minutes to reach this temperature).
7. When the fire is well-established slide the air control lever for the desired heat output.

REFUELING

To refuel the stove, open the bypass and move the primary air control to "HIGH". Let the fire "LIVEN UP" for about one minute. Open the fuel door about 1/2" and hold in this position about 30 seconds or until the stove is drafting well. Open the door and add wood. After refueling, reset the primary draft control to the desired position, and close the bypass when the catalytic temperature probe reaches operating temperatures.

CARE AND OPERATION

BLOWER SYSTEM

The Blower System consists of a ON/OFF rocker switch, a variable speed blower speed control switch (rheostat), a thermally activated switch (fan disc) and 2 axial blowers.

When starting a fire, leave the blower system off until the insert is thoroughly heated (approx. 30 minutes after start up).

The blowers can be operated in one of the following manners:

AUTO: Turn Rocker Switch to the OFF "o" position and the rheostat to the ON position (rotate rheostat dial clockwise until it clicks). When the insert warms up (110° F), the blower will automatically turn on (adjust rheostat dial to the desired speed setting). When the insert cools down (90° F), the blowers will automatically turn off.

MANUAL: Turn Rocker Switch to the ON "-" position and adjust rheostat dial to the desired speed. The Blower will have to be manually turned off by rotating the rheostat dial counterclockwise until it clicks.

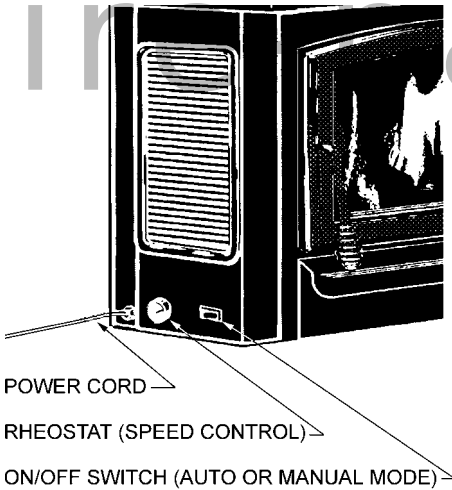

CAUTION: BURNING THE INSERT AT A HIGH BURN RATE FOR EXTENDED PERIODS WITHOUT RUNNING THE BLOWERS CAN CAUSE EXCESSIVE TEMPERATURES RESULTING IN OVERFIRING DAMAGE TO THE APPLIANCE. OVERFIRING DAMAGE IS NOT COVERED UNDER THE 5 YEAR PRO-RATED WARRANTY.

WARNING: THIS APPLIANCE IS EQUIPPED WITH A BLOWER SYSTEM WHICH HAS A FLEXIBLE ELECTRICAL POWER CORD WITH A THREE-PRONG (GROUNDING) PLUG FOR YOUR PROTECTION AGAINST SHOCK HAZARD AND SHOULD BE PLUGGED DIRECTLY INTO A PROPERLY GROUNDED THREE-PRONG RECEPTACLE PER LOCAL CODES OR NEC, ANSI / NFPA 70 - LATEST EDITION. DO NOT CUT OR REMOVE THE GROUNDING PRONG FROM THE POWER CORD PLUG. DO NOT ROUTE POWER CORD UNDER OR IN FRONT OF APPLIANCE.

BLOWER SPECIFICATIONS: 115 Volt, 60 Hz, 2 axial blowers - .42 amps each, 125 CFM each. Blower system has a flexible electrical cord that must be electrically grounded per local codes or NEC, ANSI/NFPA 70-latest edition. Do not route the power cord under or in front of the appliance.

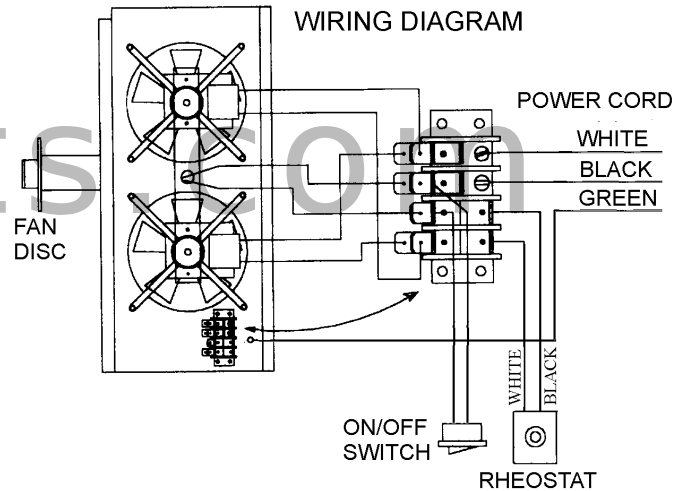

POWER FLOW DIAGRAM

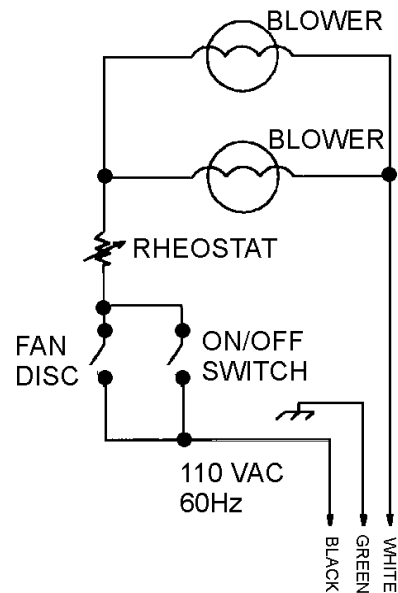

CARE AND OPERATION

BYPASS DAMPER CONTROL

The operating handle of your bypass damper control is located on the front of the stove flue collar. By moving the bypass damper control, the operator can route the fire either through the catalytic combustor (pushed in) or directly up the flue (pulled out). When starting a fire or refueling, the bypass damper control must be pulled out. Once the fire is established, it must be pushed in.

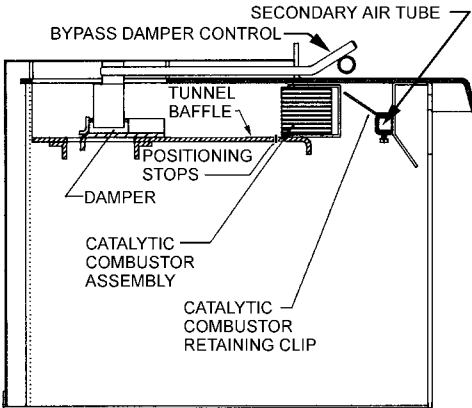

CATALYTIC TEMPERATURE PROBE

The catalytic temperature probe monitors the temperature of your catalytic combustor. Once you have established a fire and the catalytic temperature probe indicates the temperature of your catalytic combustor. When it reaches a minimum temperature of 500 degrees, close the bypass damper control (this will take approximately 20 - 25 minutes). Depending on the type and size of the fuel load as well as the length of time the stove has been burning, your temperature probe reading should be between 1000 to 1800 degrees. When the blower is operating it can affect the temperature probe reading. Turn the blower off for an accurate reading.

How it works: From 5 to 30 percent of the chemical energy contained in every log escapes up the chimney when wood is burned in a conventional stove. The catalytic combustor is designed to make use of this energy, converting it into useful heat as it lessens chimney creosote build-up and air pollution. The catalytic combustor consists of a durable temperature resistant ceramic composition, which is extruded into a cellular, or honeycomb, configuration. After extrusion, this ceramic monolith is fired and then covered with a noble-metal catalyst. When wood smoke contacts this catalyst, chemical changes occur that causes the smoke to ignite at temperatures around 500 ° F. Normally, smoke will ignite and burn only at temperatures around 1000° F.

BURN RECOMMENDED FUEL

This appliance is approved for use with natural dry wood only. Burning materials other than natural wood will shorten the life of the catalytic combustor. Do not burn particleboard or pressed logs using bonding agents as they can produce

conditions which will deteriorate metal or damage the catalyst. Green or uncured wood does not work well as fuel, and can cause increased creosote buildups and plugging of the catalytic combustor.

The value of green wood as a source of heat is limited. Do not overload or use kindling wood or mill ends for primary fuel as this may cause overfiring. Overfiring is a condition where excessive temperatures are reached, beyond the design capabilities of the fireplace insert. The damage that occurs from overfiring is not covered under the fireplace insert warranty.

WHY SEASON WOOD?

The key to the success of a good fire that produces heat from a wood burning insert is the wood. It needs to be well-seasoned natural wood.

What does "Well-Seasoned" mean?

When a tree is cut down, the wood is green, full of sap and moisture. This moisture content can exceed 80%, which must be reduced to less than 20%. Wood properly seasoned is then capable of generating the heat the fireplace insert was designed to provide.

Green wood does not burn easily. Attempting to burn green wood often results in a lot of smoke and very little fire. Time is the most important factor in seasoning wood. Ideally the moisture content should be reduced to 11-20%, although very few of us will be able to check that figure. There are several steps that should be taken to ensure that that you come close to these figures.

SEASONING GUIDE

Softwoods – 6 months to 18 months

Hardwoods – 12 months to 24 months

Logs that are 5" diameter across or larger should be split in half, three pieces if over 8 inches, and four pieces when over a foot across. If the tree was fell 2 to 4 years ago, it still needs to be cut, split, and seasoned for 6 to 24 months depending on the wood.

WOOD STORAGE

Wood to be seasoned should be stacked in an area open enough to ensure good air circulation on both sides – leaving adequate space between woodpiles to walk comfortable. Do not stack wood against a wall or building. It helps to elevate the woodpiles off the ground (two 2 x 4's running lengthwise beneath the woodpile works well). This allows air to flow under the bottom logs.

Wood that is kept outdoors, either covered with a tarp, or not covered at all, will not burn well until it has been in an enclosed space for one to two months.

MAINTENANCE

SMALL AREA PAINT TOUCH-UP

The stove body is painted with a quality high-temperature stove paint. Use only model TSPK-B Stove Paint, Catalog # 70K99. Do not touch-up your stove with any other paint.

Using one small piece of 320 grit sand paper and lightly sand the blemish so that the edges are "feathered" or smooth to the touch between the painted and bare surfaces. Do not let the sand paper gum up with paint, as this will cause scratches on the metal surface. If there are any scratches, use 600 grit sandpaper instead. Mask off surfaces you do not want painted. Paint lightly over the bare surface first as this will act as an undercoat. Then paint over a larger area in smooth even strokes to blend.

See Break-In Period on page 14 for information on curing the paint.

FIREBRICK

The firebrick should be inspected periodically and replaced if damaged (crumbling or excessively cracked).

ASH REMOVAL AND DISPOSAL

CAUTION: MAKE SURE THAT THE FIRE IS OUT AND THE STOVE IS COLD BEFORE REMOVING ASHES! NEVER BURN YOUR STOVE WITH THE ASH DUMP COVER OFF!

Ashes can hold live embers for several days, and must be disposed of with care.

Scrape ashes from the firebox through the ash dump opening into the ash drawer. After emptying, clean and replace the ash drawer.

NEVER place ashes in a cardboard box or any other combustible receptacle.

Proper Disposal of Ashes:

Ashes should be placed in a metal container with a tight fitting lid. The closed container of ashes should be placed on a noncombustible floor or on the ground, well away from all combustible materials, pending final disposal. If the ashes are disposed of by burial in soil or other wise locally dispersed, they should be retained in the closed container until all cinders have thoroughly cooled.

DOOR/GLASS GASKET AND ASH DUMP GASKET

A 3/4" spun fiberglass gasket provides the seal around the fuel door and a flat spun fiberglass rope gasket (1/8" x 1") provides the seal around the glass. A cerawool pad (4 1/4" x 4 1/4" x 1/2") provides the seal for the ash dump cover. Should these gaskets become frayed or damaged, they should be replaced with the same size and type as the original gasket. Contact your dealer for ordering. Use high temperature silicone sealer as an adhesive for replacing door and ash dump gaskets. The glass gasket has a self-adhesive backing.

WARNING: THE GASKETS MUST BE KEPT IN GOOD CONDITION. DO NOT LEAVE THE STOVE BURNING WITH THE DOOR OR ASH DUMP COVER OFF. THIS WILL CAUSE EXCESSIVE HEAT BUILD UP IN THE UNIT AND COULD IGNITE SURROUNDING COMBUSTIBLES AS WELL AS DAMAGE THE STOVE BY OVERFIRING IT. OVERFIRING IS A CONDITION WHERE EXCESSIVE TEMPERATURES ARE REACHED, BEYOND THE DESIGN CAPABILITIES OF THE STOVE (SUCH DAMAGE IS NOT COVERED BY THE MANUFACTURER'S WARRANTY).

SERVICING GLASS

CAUTION: BE CAREFUL NOT TO ABUSE DOOR ASSEMBLY BY STRIKING OR SLAMMING IT. IF THE DOOR ASSEMBLY OR GLASS IS BROKEN OR DAMAGED, THEY MUST BE REPLACED BEFORE HEATER CAN BE SAFELY OPERATED. USE ONLY COMPONENTS PROVIDED BY THE MANUFACTURER AS REPLACEMENT PARTS.

Cleaning Glass: Ensure stove is cold prior to cleaning glass. A commercial glass cleaner designed for stoves is recommended. Do not use abrasive cleaners.

Replacing Glass:

1. Remove door from stove by lifting door up and off hinge pins: Place the door on a flat protected (towel) clean flat surface with the inside of the door facing up. Remove the glass clips (by removing screws holding clips), then carefully remove broken glass one piece at a time (protective gloves are recommended).
2. Clean area where the glass with gasket will be installed.
3. Install new glass with gasket (use only factory 5-mm glass with glass channel gasket. Do not substitute). Carefully reinstall glass clips. Be very careful not to overtighten screws.
4. Reinstall door.

MAINTENANCE

CREOSOTE FORMATION AND NEED FOR REMOVAL

What is Creosote - When wood is burned slowly, it produces tar and other organic vapors, which combine with expelled moisture to form creosote. The creosote vapors condense in the relatively cool chimney flue of a slow-burning fire. As a result, creosote residue accumulates on the flue lining. When ignited this creosote makes an extremely hot fire. Also, creosote deposits tend to form in long runs of venting where gases become too cool prior to exhausting. Note: Single wall pipe cools rapidly, therefore installations using this type of flue are more susceptible to creosote deposits.

To inhibit the build up of creosote, adjust the primary air control to a medium-high or high setting for a 10-minute period each day. Do not attempt to burn out heavy creosote accumulations in this manner. This must be removed from the chimney by scraping or brushing to reduce the risk of a chimney fire.

Burn Approved Fuel Only - This stove is approved for burning dry seasoned natural wood only. Using green or inadequately seasoned wood may increase creosote buildup.

Inspection Frequency - The chimney connector and chimney should be inspected at least twice monthly during the heating season to determine if a creosote buildup has occurred. If creosote has accumulated it should be removed to reduce the risk of a chimney fire.

Cleaning - Remove the catalytic combustor and open the bypass damper prior to having your chimney cleaned (should be done by a qualified chimney sweep). See Maintenance, *Catalytic Combustor*, on page 19 for instructions on removing catalytic combustor.

IMPORTANT: MAKE SURE THE BYPASS DAMPER IS IN THE OPEN POSITION PRIOR TO CHIMNEY CLEANING.

In the event of a chimney fire - Make sure the fuel door is securely closed. Adjust the primary air control to the lowest (most closed) setting. Call the fire department immediately. After a chimney fire, the complete chimney system should be checked by a qualified technician before further use.

Consult your dealer for suggestions on proper chimney care. Contact your local municipal or provincial fire authority for information on how to handle a chimney fire. Have a clearly understood plan for handling a chimney fire.

CATALYST REPLACEMENT

The normal expected life of a catalytic combustor is 10,000 to 12,000 hours (if appliance is operated correctly and proper fuels are used). If the catalyst has been deactivated, it should be replaced. Symptoms of deactivation include – noticeably darker smoke exiting chimney and less heat output. If these symptoms remain after normal maintenance or a major cleaning (soak in heated vinegar/water solution, see page 19), the catalyst probably needs replacement. Also, if the catalyst is broken and/or missing large pieces, it should be replaced.

Note: The catalyst does not need to be glowing to be working. It will glow at times, but it can work very effectively at temperatures well below the 1000° F level at which it will begin to glow.

CLEANING BLOWERS

The blowers require inspection and cleaning annually to remove lint, dust, etc. If there are pets in the dwelling, the blowers should be cleaned at least twice a year. To access, remove blower cover (remove the two ¼" hex head screws), then inspect propellers (replace if cracked, or broken) and vacuum out lint, dust, and debris.

MAINTENANCE

CATALYTIC COMBUSTOR

This appliance has been designed with a catalytic combustor, which will improve its overall performance. Removing the combustor assembly for cleaning and reinstallation is simple and convenient. Cleaning the combustor helps reduce buildup of ash and retarding chemicals. To clean the combustor, a soft brush, vacuum cleaner, or pipe cleaner may be used.

Cleaning the combustor once a year, preferably when your flue system is serviced, is sufficient for most users. Reinstall the combustor according to the following instructions.

The catalytic activity and effectiveness of a two to three year old combustor can be improved by following this Major Cleaning Procedure - Soak the combustor in a hot cleaning solution of a 50/50 mixture of white vinegar and distilled water for 30 minutes. Then rinse by soaking in hot distilled water. After 15 minutes, remove the combustor from the rinse water and gently shake out excess water. It is unlikely that you will notice a visible difference in the combustor after this cleaning procedure. The combustor unit is fragile in comparison to the rest of the stove, so handle with care.

1. Place the combustor on the tunnel baffle as shown in illustration (ceramic honeycomb to the back and louvered slots to the front). Push it back into the tunnel baffle until it hits the positioning stops. Make sure it is sitting flat against the bottom and the sides so that it does not tilt forward and jump the positioning stops.
2. Position combustor clip over the middle of the secondary air tube as illustrated. Make sure that one of the holes in the secondary air tube is centered in the 1/2" hole on the clip. You can feel with your fingertip.
3. Tighten screw snugly, but do not over-tighten or you may spread the clip apart.

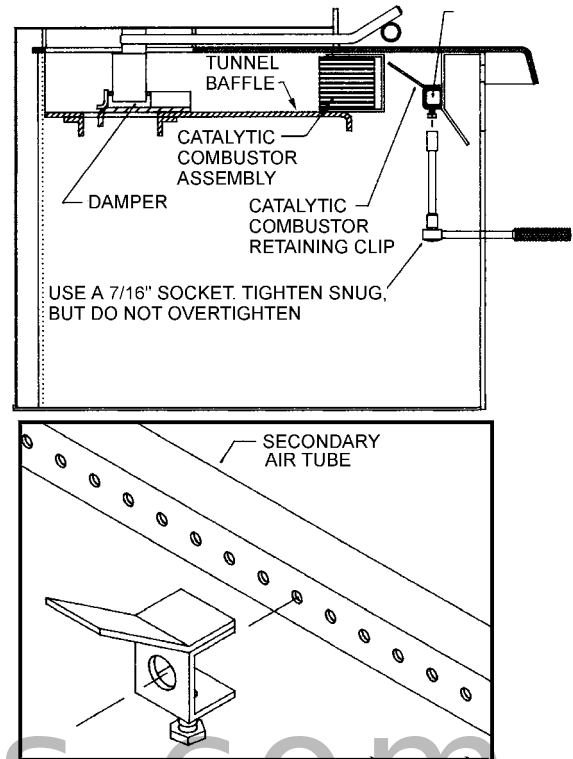

TROUBLESHOOTING

* **SMOKES OUT FUEL DOOR WHEN OPEN**

1. The primary air control is closed.
2. The chimney is too cool. Set the primary air control on "HIGH" with the bypass damper control "OPEN" for a few minutes before opening the fuel door.
3. Excess creosote will not only restrict your draft but it will create a risk of a creosote fire. Strictly adhere to maintenance requirements as outlined in this manual. If excess creosote has built up on the inside of the firebox sides and door, burn a small hot fire at intervals that are more frequent with air control on HIGH for a few minutes.
4. Deposits may have built up in the chimney and are restricting the draft, or the spark arrester on top of the chimney may be plugged.
5. Chimney diameter too large or too small to provide adequate draft.
6. The house is too airtight (usually takes 20 to 30 minutes for problem to appear as stove lowers air pressure in house). Crack a window open or provide an outside source of air near insert.
7. Insufficient vertical height to chimney to achieve adequate draft.
8. The combustor is plugged from engaging too soon (remove combustor and clean, see Maintenance section, page 19).

* **DOES NOT PRODUCE ENOUGH HEAT**

1. Using green or insufficiently cured wood.
2. Excessive draft.
3. High ceilings (heat rises quickly, but can be recirculated by a well-placed ceiling fan with a winter/summer switch).
4. The area to heat, is too large (square foot heating estimates are based on "average" climates and home design.)
5. There's an obstruction in the chimney.
6. The chimney or chimney cap is restricted by creosote preventing enough draw to sustain a "HIGH" heat rate.
7. Combustor light off has not occurred.

* **DOES NOT MAINTAIN A FIRE**

1. Soft wood does not burn as long or as well as seasoned hardwood resulting in a short burn time.
2. Wood size too small. Burns at too rapid a rate.
3. The gasket seal on the fuel door, ash dump cover or glass is leaking air. Repair or replace it if necessary.
4. There is an obstruction in the chimney.
5. The stove was not up to normal operating temperature before the bypass damper control was pushed closed.
6. Excessive draft.

* **BACKPUFFING**

1. Downdraft in the chimney (may need a special wind cap).
2. The catalytic combustor is too hot (avoid burning soft, pitchy woods, or large amounts of small-diameter wood).
3. The house is too air tight (ventilation is needed).
4. Insufficient vertical height to chimney to achieve adequate draft.

ODORS

1. Creosote accumulation in firebox (brush out on next cleaning).
2. Chimney downdraft when stove is not operating (close primary air control).
3. Catalytic combustor not functioning.
4. Paint curing on first several burns.

* **DIRTY GLASS**

1. Poor draft conditions.
2. Long burn periods at low draft settings.
3. Burning wet, pitchy or spongy wood.
4. Poorly arranged logs (too close to glass).

CATALYST PLUGGING

1. Burning materials that produce a lot of char and fly ash. Do not burn materials such as garbage, gift wrap, cardboard, etc.
2. Burning wet pitchy woods or burning large loads of small diameter wood with the combustor in the operation position (without light-off taking place). Burn proper fuel only. Do not close bypass until temperatures are high enough to initiate light off.

CATALYST DEACTIVATION

1. Burning large quantities of trash, pressure-treated lumber or painted woods, etc. will deactivate the catalyst. Burn proper fuels only. See *Catalyst Replacement*, page 19.

CATALYST SUBSTRATE CRACKING

1. Normal operation, as long as combustor remains intact. If cracking causes large pieces to fall out, replace combustor.
2. Mishandling or abuse. Handle with care.
3. Warped housing (see *Overfiring*, this page).

* **Draft problems; If installing into a larger flue, it may be necessary to use a full length liner to achieve adequate draft for the appliance. A draft gauge should read a minimum of .05" w.c. (inches water column) not to exceed .07" w.c. for optimum performance (see *draft requirements*, page 5).**

TROUBLESHOOTING

CATALYST SUBSTRATE

1. Extreme thermal shock. Combustor is being worked too hard.
2. Excessive draft. Correct installation. See *Draft Requirements*, page 5

CATALYST PEELING

Extreme Temperatures (over-firing) at combustor surface can cause the catalyst to peel. Some minor peeling does not affect function. Severe peeling would close cell openings and cause a plugging problem. If peeling is severe, replace combustor. Do not overfire appliance. See *Overfiring*, this page.

TAR AND LIQUID CREOSOTE LEAKING FROM METAL FLUE JOINTS

1. No chimney cap on chimney. Install cap.
2. Metal flue assembled improperly. Top flue sections should be inserted into lower flue sections.

DENSE SMOKE LEAVING CHIMNEY

1. Water vapor (on cold still days water vapor may be mistaken for smoke). Water vapor is normal and should be of little concern.
2. Wet, pitchy woods being burned. Burn dry seasoned wood only.
3. Bypass in open position. Close bypass.
4. Combustor not functioning. See Catalyst Replacement, page 19.

OVERFIRING

If any part of the appliance glows, it is overfiring. Other symptoms may include: Cracking, warping or burning out of components, catalytic combustor may deteriorate, gold doors may turn color, stove glass may develop a haze which will not come off with cleaning, firebox baffle plate (tunnel baffle) may warp, etc.

Overfiring of a fireplace insert is a condition where excessive temperatures are reached, beyond the design capabilities of the appliance (as outlined in the following 4 paragraphs). The damage that occurs from overfiring is not covered under the manufacturers limited warranty. The following are a few conditions that should be evaluated and (corrected if necessary) if an overfiring condition is suspected:

Overfiring Caused From Improper Installation

The venting system must satisfy the draft Requirements of the appliance. The appliance is merely one component of a larger system. The other equally important component is the venting system, which is necessary for achieving the required flow of combustion air to the fire chamber and for safely removing unwanted combustion byproducts from the appliance. If the venting system's design does not promote these ends, the system may not function properly, which may create performance problems as well as may be a safety hazard. To ensure that all installation requirements have been met as outlined in the installation manual. The chimney should be clean and in good repair. A draft test should be performed to determine if the draft requirements of the appliance are being met. A draft gauge should read between .05 and .07 inches W.C. (water column.). Excessive draft (above .07" W.C.) will allow too much combustion air to be pulled into the firebox, which results in hotter burns. Too little draft (below .05" W.C.) will not allow enough combustion air delivery to maintain a fire well or cause performance problems such as smoking (this may result in improper operation of appliance, i.e. will not maintain fire well unless catalytic bypass is left open, or with fuel door left open – see Operation).

Overfiring Caused From Improper Operation

Never burn the appliance with the fuel door open or ajar, the ash dump cover off or the ash drawer open. Never burn the stove with the bypass handle in the open position once the fire has been established or the air control in the "high" position for extended periods.

Overfiring Caused From Improper Maintenance Strictly adhere to all maintenance requirements at frequent intervals as prescribed in this manual including cleaning of flue and fireplace insert. Should the fuel door, ash dump or glass gaskets become worn or damaged, they should be replaced.

Overfiring Caused From Improper Fuel

This appliance is approved for use with natural dry well seasoned wood only (consult your dealer for approved fuels in your area). Do not burn garbage, particleboard scraps, or pressed logs using bonding agents because they can produce conditions that will deteriorate metal. Green or uncured wood does not work well as fuel, and can cause increased creosote buildups. Do not overload or use kindling wood or mill ends as primary fuel.

SPECIFICATIONS - Model BV4000C-2

Maximum log length	18" / 457 mm
Flue size	6" / 152 mm
Width w/standard surround	42" / 107cm
Width at fireplace opening	22.5" / 572 mm
Width at rear of firebox	22.5" / 572 mm
Depth into Fireplace	16" / 406 mm
Depth (overall)	25" / 635 mm
Height	21" / 533 mm
Height w/standard surround	32" / 813 mm
Back of Stove to Center of Flue	5 1/2" / 140mm
Approx. burn time	8 - 10 hours
Fuel capacity	70 lbs. / 32 kg (approx.)
Firebox size (cubic feet)	2.4 c.f. (732 cubic mm)
Maximum Burn Rate	56,800 BTU
EPA BTU Range	6,500 to 40,900 BTU
EPA Efficiency	72%
Emissions Rate (grams/hour)	1.9 gph
Weight with brick	390 lbs. / 177 kg (approx.)
Air Control	Manual
Blower Assembly (2 blowers, 125cfm each)	250 cfm
W/ speed control Rheostat	75 – 110 volt

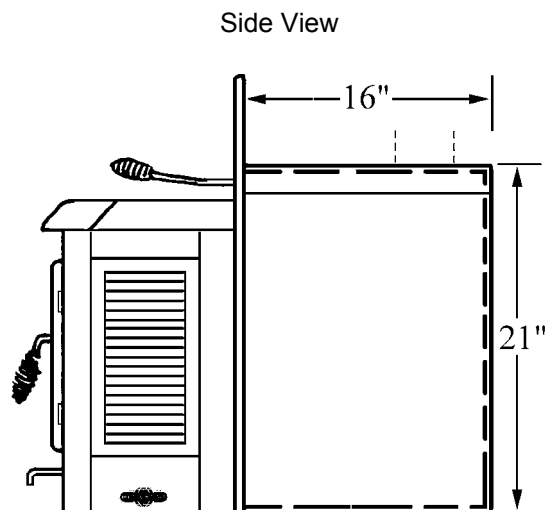
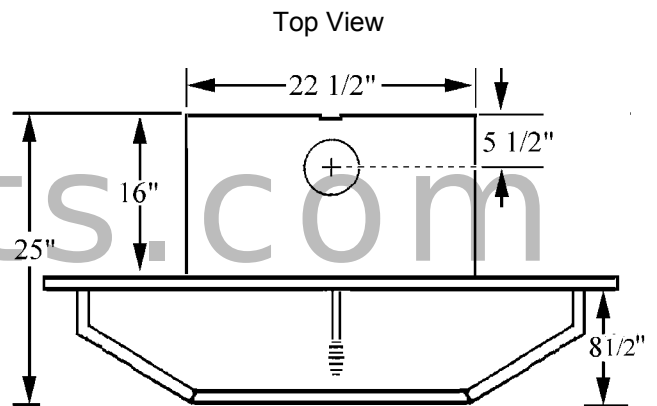
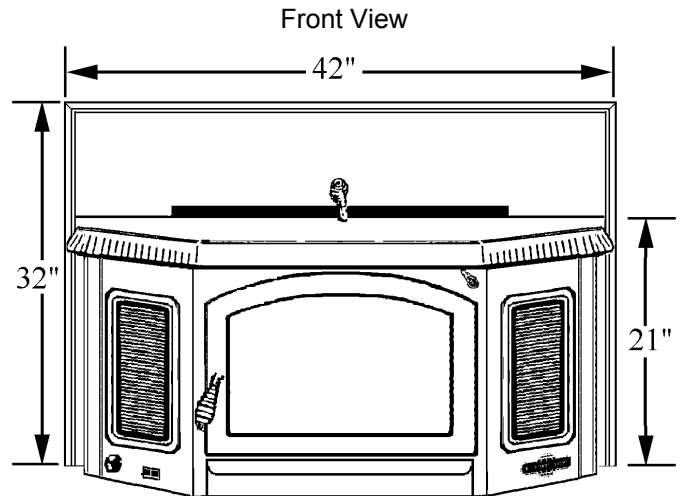

Note: Dimensions shown are approximations only (+/- 1/4").

REPLACEMENT PARTS LIST – Model BV4000C-2

Door Parts (See page 26 for Gold Door Kit)	
G6000	Door Kit, Black
27M67	Clip Set, Glass
10300	Door Handle Assembly
86-128	Gasket Kit, 3/4" Door Rope (Includes Adhesive)
27M81	Gasket Kit, Glass (10' of 10580)
G2000-7	Glass, Arched 9 3/8 x 15 3/4" (Gasket not included)
11529	Hinge Pin 10 L 18 (Original) - Requires welding
11531	Hinge Pin, Retrofit (requires drill #3 [.213"] & tap 1/4"-28 UNF. order 2 if set is needed)
10362	Torque Plate (Latch)
Catalytic Combustor Parts	
11000	Clip, Combustor
14000	Combustor Assembly 3" (*SN>4645) - Includes ceramics, gasket & housing
11481H	Gasket, Interam Combustor (1/16 x 3 x 36") 11481
C-200-51	Hook, Damper (Coil handle with hook for opening / closing damper bypass)
BV100	Probe, Combustor Temperature
11485	Housing, Combustor
Room Air Blower Parts	
LB-101495	Blower Assembly (includes 2 blowers w/ propellers, mounting bracket and terminal block)
11565	Disc, Low Limit (fan disc, F110°-20F)
11597	Wire Harness, Blower
10050087	Knob, Rheostat (02107)
LB-101496	Motor, Blower, 1 ea. (includes propeller)
26M22	Power Cord (02071)
42M1401	Propeller, Metal Blower Motor
528	Rheostat, Blower Speed Control (knob, p/n 10050087, not included) 02082
410-270	Switch, On/Off (Bypass)
410-260	Terminal Block, Large
Surround Parts (see page 26 for Surround Kits)	
11817	Trim, Air Intake Housing Gold
2046	Bracket, Surround Trim ("L" bracket / corner key. order 2 if set is needed) 02046
00010H	Dart, Plastic, 1 ea. (for brass air intake trim) – Note: 4 required on each side
26M71	Insulation Set, Surround (11842 & 11843)
2047	Trim, Gold Tone, Surround 32" x 42"
430XL	Trim, Gold Tone, Surround 32" x 48"

REPLACEMENT PARTS LIST – Model BV4000C-2

Miscellaneous Parts	
26M31	Ash Drawer Assembly (11777)
11807	Panel, Left Blower (louvered body panel)
11809	Panel, Right Blower (louvered body panel)
26M68	Module Assembly, Draft Control (11493)
70K99	Paint Kit, Metallic Black (12 oz. Spray #6309)
Firebox Parts	
11709	Cover, Ash Dump (w/ Gasket 4 1/4 x 4 1/4 x 1/2")
26M73	Damper Kit (Includes damper, linkage and rod)
FB10	Firebrick, 4 1/2 x 1 1/4" ♦
FB11	Firebrick, 4 1/2 x 4 3/8" ♦
FB29	Firebrick, 9 x 1" ♦
FB9	Firebrick, 9 x 1" w/notch ♦
FB7	Firebrick, 9 x 2 1/8" (order 2, if set is needed) ♦
FB-1	Firebrick, 9 x 4 1/2" (order 7, if set is needed) ♦
FB-2	Firebrick, 9 x 4 1/2" w/notch (order 4, if set is needed) ♦
11811H	Gasket, Ash Dump (4 1/4 x 4 1/4 x 1/2") 11811
37075	Grate, 4 1/2 x 4 3/8" (order 2, if set is needed)

- ♦ All firebrick are 1 1/4" thick

For the location of the nearest dealer for replacement parts, contact:

Lennox Hearth Products
1110 West Taft Avenue
Orange, WA 92865

COMPONENT DIAGRAMS – Model BV4000C-2

CATALOG/ PART #	QTY	DIMENSIONS
FB-1	7	9 x 4 1/2" Regular
FB-2	4	9 x 4 1/2" W/Notch
FB10	1	4 1/2 x 1 1/4" Regular
FB11	1	4 1/2 x 4 3/8" Regular
FB7	2	9 x 2 1/8" Regular
FB29	1	9 x 1" Regular
FB9	1	9 x 1" W/Notch

NOTE: ALL BRICK ARE 1 1/4" THICK

SIDES

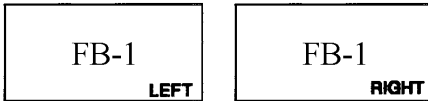

BACK

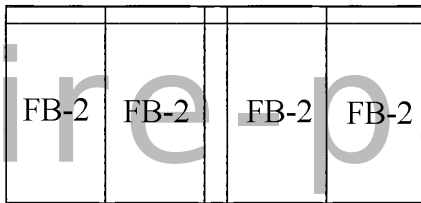
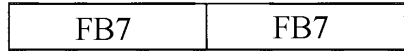

↑
FB9

BOTTOM

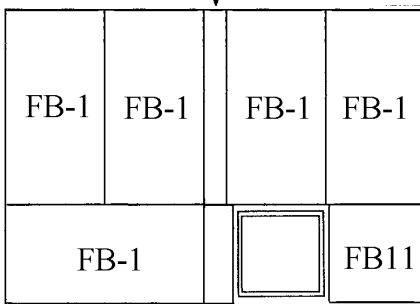

↑
FB10

DAMPER ASSEMBLY (CATALOG #26M73)

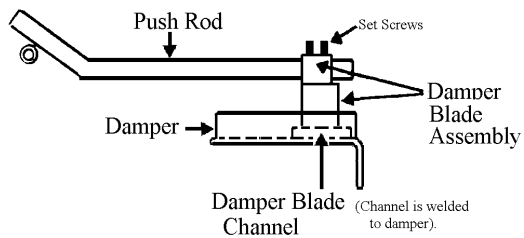

CATALYTIC/DAMPER COMPONENTS

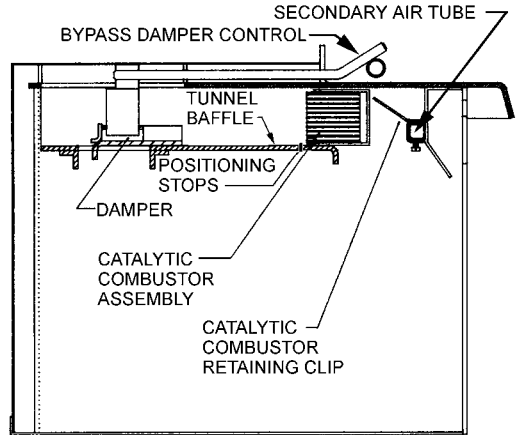

PRIMARY AIR CONTROL DRAFT MODULE (CATALOG #26M68)

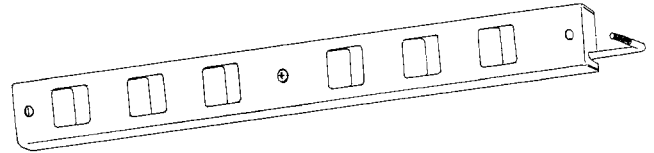

HANDLE ASSEMBLY (P/N LB-102214)

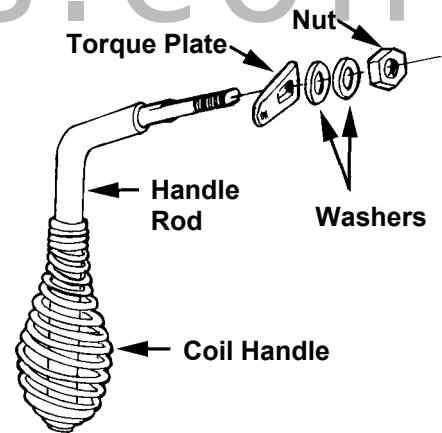

DOOR ASSEMBLY - Cat. No. 14M72 (Gold) and Cat No. H0533 (Black) - Includes Handle Assembly, Not Shown

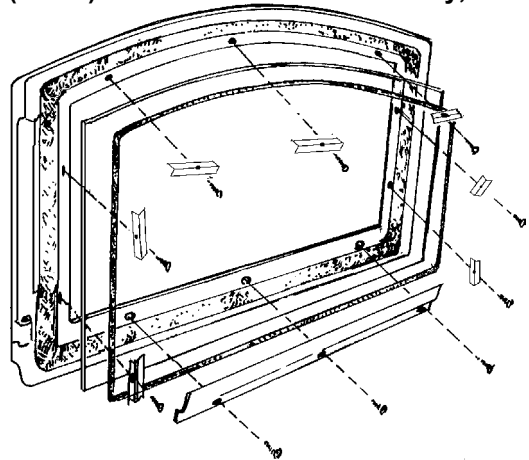

OPTIONAL ACCESSORIES - Model BV4000C-2

Accessories		
Catalog #	Model	Description
14M73	CCOK-4000	Cord Change Over Kit
14M72	DK100-G	Gold Door Kit
70K99	TSPK-B	Touch-up spray paint kit, Black , 12 oz Spray Can
14M71	SKL-4000	Surround Kit, Large, 32" ht. X 48" wd.
H0471	SKM-4000	Surround Kit, Medium, 32" ht. X 42" wd.
14M76	OA4000-66	Offset adapter, 6" to 6" diameter

OFFSET ADAPTER

Installations requiring offsets can be handled using an offset adapter (it aligns starter pipe with flue).

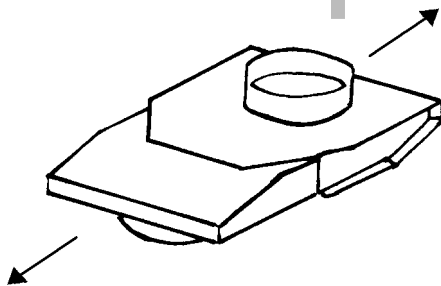
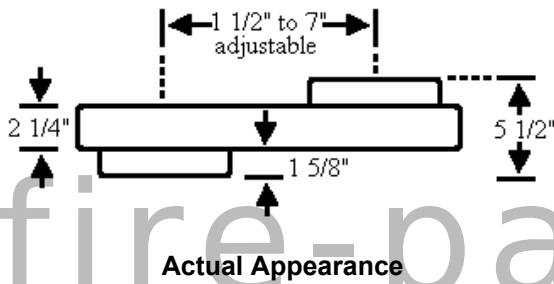

CORD CHANGEOVER KIT

The blower system can be easily transferred to the other side of the insert along with the power cord by installing this *cord changeover kit*. This kit consists of a reversed right and left panels (with cord hole, switch and rheostat openings on the right panel).

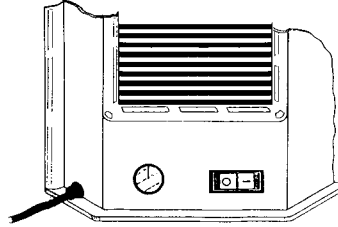

Power cord, blower assembly and controls come standard on the left side of insert as shown in illustration to the left.

With the use of this kit, the power cord and blower system can be transferred to the right side of insert as shown in illustration to the right).

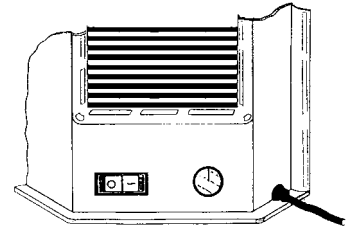

GOLD DOOR KIT

This 24-karat gold plated door is nearly maintenance free, requiring only an occasional wipe down of the gold frame (to remove fingerprints). The gold cures to a very hardened durable finish and will maintain a beautiful gold luster for many years (and it will never tarnish as brass doors do).

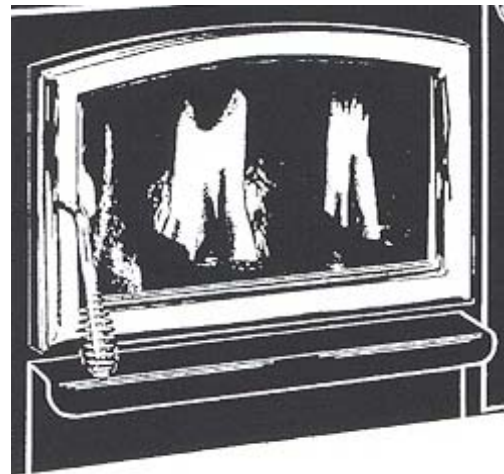

For the location of the nearest Dealer for optional parts, contact:

Lennox Hearth Products
1110 West Taft Avenue
Orange, CA 92865

SAFETY LISTING LABEL - Model BV4000C-2

CONTACT YOUR LOCAL BUILDING OR FIRE OFFICIALS ABOUT RESTRICTIONS AND INSTALLATION INSPECTION IN YOUR AREA
 CONTACTEZ LE BUREAU DE LA CONSTRUCTION OU LE BUREAU DES INCENDIES AU SUJET DES RESTRICTIONS ET DES INSPECTIONS D'INSTALLATION DANS VOTRE VOISINAGE

Listed Fireplace Accessory/Insert / Cheminée Insérée Enregistrée Avec Accessoires
 FOR USE WITH SOLID WOOD FUEL ONLY / POUR USAGE AVEC LE BOIS SEULEMENT



Manufactured by / Manufacturé par:
 LENNOX HEARTH PRODUCTS
 1110 West Taft Avenue
 Orange, CA 92865

Model / Modèle: Bayview 4000C-2
 Cat. No.: H0470
 Tested to/Testé à: UL 1482, ULC S628
 Serial No. / Numéro de série:



Tested & Listed By: Beaverton Oregon USA
 OMNI-Test Laboratories, Inc.
 Report No./Numéro de Rapport: 030-S-05-2
 Tested / Testé: March 31, 1987

"PREVENT HOUSE FIRES"

Install and use only in accordance with manufacturer's installation instructions and your local building codes.

CAUTION: Do not pass chimney connector through a combustible surface. Do not connect this unit to a chimney flue serving another appliance.

Approved for installation in listed zero-clearance fireplaces in USA. Zero-clearance installations require a full reline from the flue collar to the rain cap. For flue collar offsets use only part #14M76. See manual for further information. Zero-clearance installation is not allowed in Canada.

Electrical Rating: Aerovox, S10625082 motor, 115 VAC, .5 Watts, 60 Hz

DANGER: Risk of electrical shock. Disconnect power before servicing unit. Do not route power cord under or in front of appliance.

CATALYTIC COMBUSTOR: Applied Ceramics (Part No. 14000). Burning of metal foils, coal, plastic, garbage, diesel oil and sulphur will make the catalyst in the converter inactive. The combustor is fragile; handle carefully. Do not operate without catalyst. The performance of the catalytic device or its durability has not been evaluated as part of the certification.

NOTE: Replace glass only with 5mm ceramic.

"PRÉVENTION DES FEUX DE MAISON"

Installez et utilisez en accord avec les instructions d'installation du fabricant et des codes locaux.

AVIS: Ne pas faire passer le tuyau de cheminée à travers une surface combustible. Ne pas connecter cet appareil à un tuyau de cheminée servant un autre appareil.

Approuvé pour l'installation dans les États-Unis pour les cheminées enregistrées sans espaces libres. Les installations sans espaces libres exigent une doublure entière du col du tuyau jusqu'au capuchon de pluie. Pour le col du tuyau utilisez la pièce #14M76. V annuel pour des instructions supplémentaires. L'installation sans espaces libres n'est pas légale au Canada.

Puissance Électrique: Moteur Aerovox S10625082, 115 VAC, .5 Watts, 60 Hz

DANGER: Il y a risque de décharge électrique. Déconnectez le fil électrique de la prise de contact avant le service. Ne pas faire passer le fil électrique sous ou en avant de l'appareil.

COMBUSTEUR CATALYTIQUE: Applied Ceramics (pièces nu.: 14000). Brûler des feuilles de métal, du charbon, du plastique, des vidanges, de l'huile diesel et du soufre rendra le catalytique inactif. Le combusteur est fragile; en prendre bon soin. Ne pas opérer sans le catalytique. La performance du mécanisme catalytique ou sa durabilité n'ont pas encore été évaluées comme faisant partie de la certification.

NOTE: Remplacez la vitre avec une céramique de 5mm seulement.

Minimum Clearance to Combustible Materials (in inches)

Install insert with a minimum of 17" (432mm) clearance to combustible sidewall, 9" (229mm) to side and 24" (610mm) to top trim, 32" (813mm) from top of insert to mantel.

Floor protector must be non-combustible material, extending 16" in front of insert and 8" to both sides of the feed door opening.

*In Canada, floor protector must extend 18" (450mm) in the front of insert and 8" (200mm) to both sides of insert.

Install in masonry fireplaces built to UBC Chapter 37. Do not remove brick or mortar from masonry fireplace to accommodate insert. Masonry fireplace installation requires a minimum of a positive flue connection. In Canada, a full length S635 flue liner is required.

Use flue outlet with a direct connector. Remove and clean behind unit frequently, as creosote buildup may occur rapidly.

Espaces Libres Minimum Aux Combustibles (en pouces)

Installez la pièce insérée avec un minimum de 17" (432mm) d'espace libre au mur de côté combustible, 9" (229mm) du côté et 24" (610mm) de la garniture du haut, 32" (813mm) du haut de la pièce insérée au manteau de la cheminée.

*Le protecteur de plancher doit être de matériel incombustible, s'étendant de 18" (450mm) en avant de l'appareil et de 8" (200mm) de chaque côté de l'ouverture l'appareil.

Installez les cheminées en briques selon UBC Chapitre 37. Ne pas enlever des briques ou du ciment de la cheminée en brique de façon à accommoder la pièce insérée. L'installation de la cheminée en briques exige un connecteur de tuyau positif. Au Canada, une doublure de tuyau de grandeur de S635 est exigée.

Raccorder la cheminée directement à la conduite de sortie de l'appareil. Débrancher la cheminée et nettoyer fréquemment derrière l'unité, le creosote pouvant s'y accumuler rapidement.

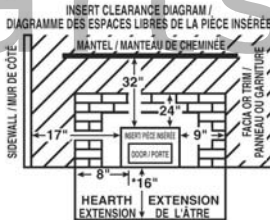

Front enclosure trim kit required for installation.
 L'ensemble de garniture avant doit être installé avec cette unité.

CAUTION: HOT WHILE IN OPERATION. DO NOT TOUCH. CONTACT MAY CAUSE SKIN BURNS. KEEP CHILDREN, CLOTHING, FURNISHINGS AND COMBUSTIBLE MATERIAL A CONSIDERABLE DISTANCE AWAY. SEE NAMEPLATE AND INSTRUCTIONS. DO NOT OVERFIRE. IF HEATER OR CHIMNEY CONNECTOR GLOWS, YOU ARE OVERFIRING. INSPECT AND CLEAN CHIMNEY AND CONNECTOR FREQUENTLY. UNDER CERTAIN CONDITIONS OF USE, CREOSOTE BUILDUP MAY OCCUR RAPIDLY. DO NOT USE GRATE OR ELEVATE FIRE - BUILD WOOD FIRE DIRECTLY ON HEARTH. DO NOT BURN WITH FEED DOOR OR FLUE BYPASS OPEN. FEED DOOR MUST BE CLOSED DURING FIRING EXCEPT WHEN ADDING FUEL. OPEN FLUE DRAFT AND BYPASS BEFORE OPENING FEED DOOR.



ATTENTION: CHAUD LORS DE L'OPÉRATION. NE PAS TOUCHER. LE CONTACT PEUT CAUSER DES BRÛLURES À LA PEAU. GARDEZ LES ENFANTS, LES VÊTEMENTS, LES MEUBLES ET LES MATÉRIELUX COMBUSTIBLES LOIN DE L'ESPACE DÉSIGNÉ DE L'APPAREIL. VOIR L'ÉTIQUETTE ET LES INSTRUCTIONS. NE PAS SURCHAUFFER. SI L'APPAREIL DE CHAUFFAGE OU LE TUYAU DE CHEMINÉE ROUGISSENT, VOUS SURCHAUFFEZ. INSPECTEZ ET NETTOYEZ LA CHEMINÉE FRÉQUEMMENT. SOUS CERTAINES CONDITIONS, IL SE PEUT QUE LA CRÉOSOTE S'ACCUMULE RAPIDEMENT. N'ÉLEVEZ PAS LE FEU. BÂTISSEZ LE FEU DE BOIS DIRECTEMENT SUR L'ÂTRE. NE PAS BRÛLER LORSQUE LA PORTE D'OUVERTURE OU LA PORTE BY-PASS SONT OUVERTES. LA PORTE D'OUVERTURE DOIT ÊTRE FERMÉE PENDANT L'USAGE EXCEPTÉ PENDANT QUE VOUS AJOUTEZ DU FEU. OUVREZ LE TUYAU D'AIR ET LA PORTE BY-PASS AVANT D'OUVRIR LA PORTE D'OUVERTURE.

U.S. ENVIRONMENTAL PROTECTION AGENCY
 Certified to comply with July 1990 particulate emission standards.

This wood heater contains a catalytic combustor, which needs periodic inspection and replacement for proper operation. Consult owner's manual for further information. It is against the law to operate this wood heater in a manner inconsistent with operating instructions in the owner's manual, or if the catalytic element is deactivated or removed.

DATE OF MANUFACTURE / DATE DE FABRICATION

2002 2003 2004 Jan. Feb. Mar. Apr. May Jun. Jul. Aug. Sep. Oct. Nov. Dec.

Manufactured by: Lennox Hearth Products Model: Bayview 4000C-2

US ENVIRONMENTAL PROTECTION AGENCY

CATALYST EQUIPPED

MEETS EPA PARTICULATE MATTER (SMOKE) CONTROL REQUIREMENTS FOR CATALYTIC WOOD HEATERS BUILT ON OR AFTER JULY 1, 1990. SEE CATALYST WARRANTY. ILLEGAL TO OPERATE WHEN CATALYST IS NOT WORKING. SEE OWNER'S MANUAL FOR OPERATION AND MAINTENANCE.

SMOKE

THIS MODEL

0 (Grams Per Hour) 5.5

EFFICIENCY*

50% 60% 70% 80% 90% 100%

Wood heaters with higher efficiencies cost less to operate.
*(NOT TESTED FOR EFFICIENCY. THE VALUE INDICATED IS FOR SIMILAR CATALYST-EQUIPPED WOOD HEATERS.)

HEAT OUTPUT
6,600 to 40,900 Btu/Hr

Use this to choose the right size appliance for your needs.
ASK DEALER FOR HELP

This wood heater will achieve low smoke output and high efficiency only if properly operated and maintained. See owner's manual.

fire-parts.com

LENNOX[®]

HEARTH PRODUCTS
1110 West Taft Avenue
Orange, CA 92865