

ADDENDUM M-11-0005

DATE: 9/28/11

TO: All Mendota Dealers and Customers

FROM: Mendota Engineering Department

SUJECT: New Quick-Conversion style Pilot Light Assemblies

Mendota ZC Fireplaces and Insert models DXV35DT3 LX, DXV45DT3 LX, FV33i, FV44i and FV41 produced after August 1, 2011 utilize a quick-conversion design that incorporates a push-pull tab to convert between NG and LPG configurations. Some existing stock of Fireplaces and Inserts may contain the original Round Hood SIT pilot light assembly.

NOTE: The new Quick-Conversion design pilot assemblies are backwards compatible and can replace the Round Hood Design pilot light assemblies. It is important to make certain that you select the proper Pilot Flame Hood design when replacing a pilot light assembly. Two designs exist: 2-way Hood and 3-way Hood. Make certain you use the proper Hood Configuration for your specific model.

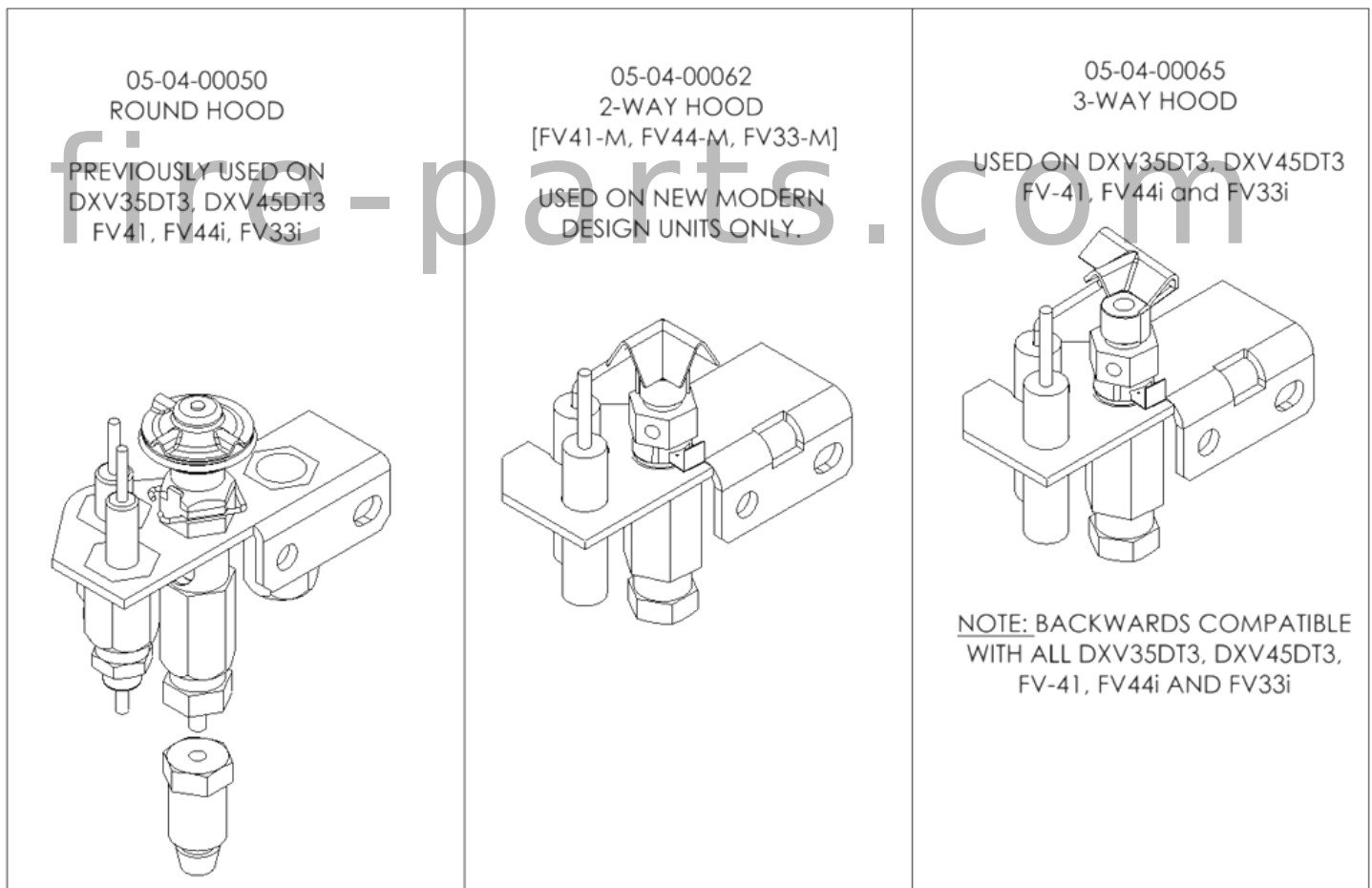

ADDENDUM M-11-0005

Existing stock of LP Conversion Kits for these models may have a pilot light orifice thimble included that is not applicable or required for the new style pilot light. If you encounter this new pilot light design and are converting the unit to burn LPG. Follow these instructions to convert the pilot light to burn LPG.

WARNING: YOU MUST USE THE REMAINING PARTS SUPPLIED IN THE LP CONVERSION KIT AND FOLLOW ALL OTHER INSTRUCTIONS SUPPLIED WITH THAT KIT TO CHANGE THE MAIN BURNER ORIFICES AND GAS VALVE PRESSURE REGULATOR TO BURN LP GAS.

Follow these steps to convert the pilot light assembly.

1. Loosen Pilot Light's hex shape base using a 1/2" open end wrench. Rotate counter clock-wise 1/4 turn to loosen.
2. Pilot arrives from the factory set for NG. Push NG/LP Adjustment Clip inward all the way to set it for LP.
3. See detail view, below. If you see "NAT" printing on the Adjustment Clip, this indicates that the pilot is set to burn NG. Push Clip in so that "NAT" is not visible. Tighten down Hex shaped base of pilot using a 1/2" open end wrench.

