

**INSTALLER/CONSUMER
SAFETY INFORMATION**

**PLEASE READ THIS MANUAL
BEFORE INSTALLING AND
USING APPLIANCE**

WARNING!
IF THE INFORMATION IN THIS
MANUAL IS NOT FOLLOWED
EXACTLY, A FIRE OR EXPLO-
SION MAY RESULT CAUSING
PROPERTY DAMAGE, PER-
SONAL INJURY OR LOSS OF
LIFE.

FOR YOUR SAFETY
Installation and service must be
performed by a qualified in-
staller, service agency or the
gas supplier.

WHAT TO DO IF YOU SMELL GAS:

- Do not try to light any appliance.
- Do not touch any electric switch; do not use any phone in your building.
- Immediately call your gas supplier from your neighbor's phone. Follow the gas suppliers instructions.
- If you cannot reach your gas supplier call the fire department.

**DO NOT STORE OR USE GASO-
LINE OR OTHER FLAMMABLE
VAPORS AND LIQUIDS IN THE
VICINITY OF THIS OR ANY
OTHER APPLIANCE.**

**WARNING: Improper installation,
adjustment, alteration, service or
maintenance can cause injury or
property damage. Refer to this
manual. For assistance or additional
information, consult a qualified
installer, service agency or the gas
supplier.**

TEMCO

FIREPLACE PRODUCTS

Direct Vent Zero Clearance Gas Fireplace Heater

Models: DV5200N/P, DV6400N/P

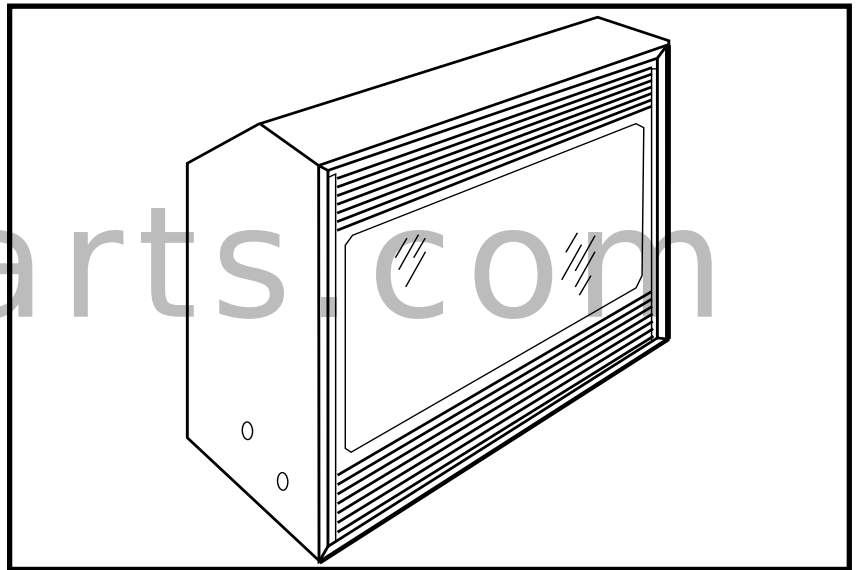

Homeowner's Installation and Operating Manual



U.S. Patents: 5,669,374; 5,562,088; 6,138,667: Can. Patent: 2,139,684

Temco Fireplace Products

410 Admiral Blvd. • Mississauga, Ontario, Canada L5T 2N6 • 905-670-7777

INSTALLER: DO NOT DISCARD THIS MANUAL - LEAVE FOR HOMEOWNER

77531 2/04 Rev. 19

Table of Contents

PLEASE READ THE INSTALLATION & OPERATING INSTRUCTIONS BEFORE USING APPLIANCE.

Thank you and congratulations on your purchase of a Temco Fireplace Products fireplace.

While we have written these instructions as accurately and thoroughly as possible, they may not cover every system, variation or contingency. Also, questions of interpretation may arise. For more information, solutions to particular problems or clarifications, contact your local distributor or the manufacturer. See the unit rating plate for whom to contact.

IMPORTANT: Read all instructions and warnings carefully before starting installation. Failure to follow these instructions may result in a possible fire hazard and will void the warranty.

Installation & Operating Instructions

Important Curing/Burning Instructions	3
Locating Your Fireplace	3
Fireplace Dimensions	4
Framing & Finishing	5
Clearance to Combustibles	6
Combustible Sidewall Clearance	6
Mantels	6
Hearth	6
Surround Material	6
Gas Specifications	7
Gas Inlet and Manifold Pressures	7
Gas Line Installation	7
Sediment Trap	8
Thermostatic Fan Kit - Optional	8
Electrical Services	8

General Venting Information

General Venting	8
General Venting Information - Termination Location	9
Sidewall (General) Venting Information	11
Flex Venting	11
Sidewall (Horizontal) Venting	12
Flex Vent Offsets	12
Flex Vent Through the Roof (Vertical) Applications	13
VSK7 Vertical Flex Vent Kit Installation	14
TDV Series Direct Vent System Installation	15
Sidewall (Horizontal) Venting, General	15
Through the Roof (Vertical) Venting	16
Elbows & Offsets - General	16
Sidewall (Horizontal) Venting Information	16
Venting Components	19

Operating Instructions

Glass Door Removal Procedure	23
Glass Cleaning	23
Louvre Installation	23
Log Installation	24
Speed Control Switch	25
Millivolt System	25
Burner ON/OFF	25
Managing Heat Output	26
Fan Operation	26
Flame Characteristics	26
Lighting & Operating Instructions	27
Troubleshooting	28

Maintenance

Unit Adjustment	31
Maintenance	31
Glass Door Replacement	32

Replacement Parts

Servicing	34
-----------------	----

Warranty

Installation and Startup Checklist	36
Warranty Registration	38

Installation & Operating Instructions

This gas appliance should be installed by a qualified installer in accordance with local building codes and with current **CSA-B149.1** Installation codes for Gas Burning Appliances and Equipment. For U.S.A Installations follow local codes and/or the current **National Fuel Gas Code. ANSI Z223.1/NFPA 54.**

FOR SAFE INSTALLATION AND OPERATION

PLEASE NOTE THE FOLLOWING:

1. This fireplace gives off high temperatures and should be located out of high traffic areas and away from furniture and draperies.
2. Children and adults should be alerted to the hazards of the high surface temperatures of this fireplace and should stay away to avoid burns or ignition of clothing.
3. Children should be carefully supervised when in the same room as your fireplace.
4. Under no circumstances should this fireplace be modified. Parts removed for servicing should be replaced prior to operating this fireplace again.
5. Installation and any repairs to this fireplace must be performed by a qualified installer, service agency or gas supplier. A professional service person should be contacted to inspect this fireplace annually. Make it a practice to have all of your gas fireplaces checked annually. More frequent cleaning may be required due to excess lint and dust from carpeting, bedding material, etc.
6. Control compartments, burners and air passages in this fireplace should be kept clean and free of dust and lint. Make sure the gas valve and pilot light are turned off before you attempt to clean this fireplace.
7. The venting system (chimney) of this fireplace should be checked at least once a year and if needed your venting system should be cleaned.
8. Keep the area around your fireplace clear of combustible materials, gasoline and other flammable vapor and liquids. This fireplace should not be used as a drying rack for clothing, nor should Christmas stocking or decorations be hung in the area of it.
9. Under no circumstances should any solid fuels (wood, coal, paper or cardboard etc.) be used in this fireplace.
10. For safe operation, the glass door must be closed.
11. Do not use this heater if any part has been under water. Immediately call a qualified service technician to inspect the heater and to replace any part of the control system and any gas control which has been under water.
12. Do not operate appliance unless completely installed as per installation instructions.
13. This appliance may be used in a bedroom installation. Install in accordance with local building codes and regulations.
14. Never use your fireplace as a cooking device.
15. This appliance must not be connected to a flue serving a solid fuel burning appliance.

The embers supplied with your fireplace are made from a high grade rock wool and should be handled carefully. Wash your hands immediately after touching to avoid irritation. The embers must be placed correctly in order to function properly.

This appliance may be installed in an aftermarket permanently located, manufactured home or mobile home, where not prohibited by local codes.

This appliance is only for use with the type of gas indicated on the rating plate. This appliance is not convertible for use with other gases, unless a certified kit is used.

IMPORTANT:

PLEASE READ THE FOLLOWING CAREFULLY

Remove any plastic from trim parts before turning the fireplace ON.

It is normal for fireplaces fabricated of steel to give off some expansion and/or contraction noises during the start up or cool down cycle. Similar noises are found with your furnace heat exchanger or car engine. It is not unusual for your Temco Fireplace Products gas fireplace to give off some odor the first time it is burned. This is due to the manufacturing process.

**Please ensure that your room is well ventilated
-open all windows.**

It is recommended that you burn your fireplace for at least four (4) hours the first time you use it. If the optional fan kit has been installed, place the fan switch in the "OFF" position during this time.

WARNING: When purging the gas line, the glass front must be removed.

Locating Your Fireplace

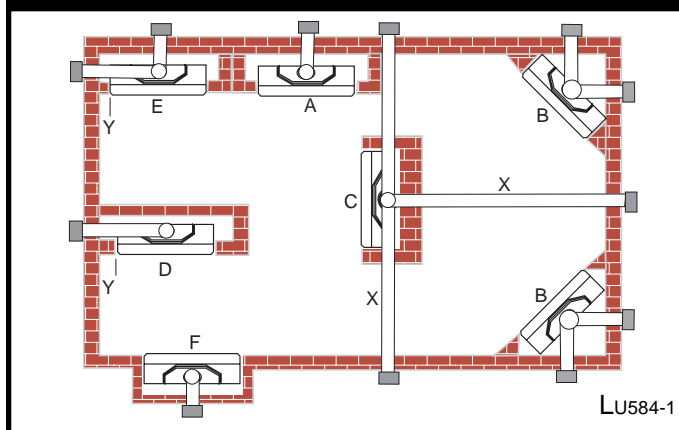

Fig. 1 Locate gas fireplace.

- | | | |
|----------------------|------------------------|------------------|
| A) Flat on wall | B) Cross Corner | C) As an Island |
| D) As a room divider | E) Flat on wall corner | F) Exterior wall |

Island installation is possible as long as the horizontal portion of the vent system does not exceed maximum recommended horizontal run as outlined in the venting chart on Page 10. When you install your fireplace as in position 'B', 'D' or 'E', (Fig. 1) a minimum of 1" (25mm) clearance must be maintained from the perpendicular wall and the front of the appliance.

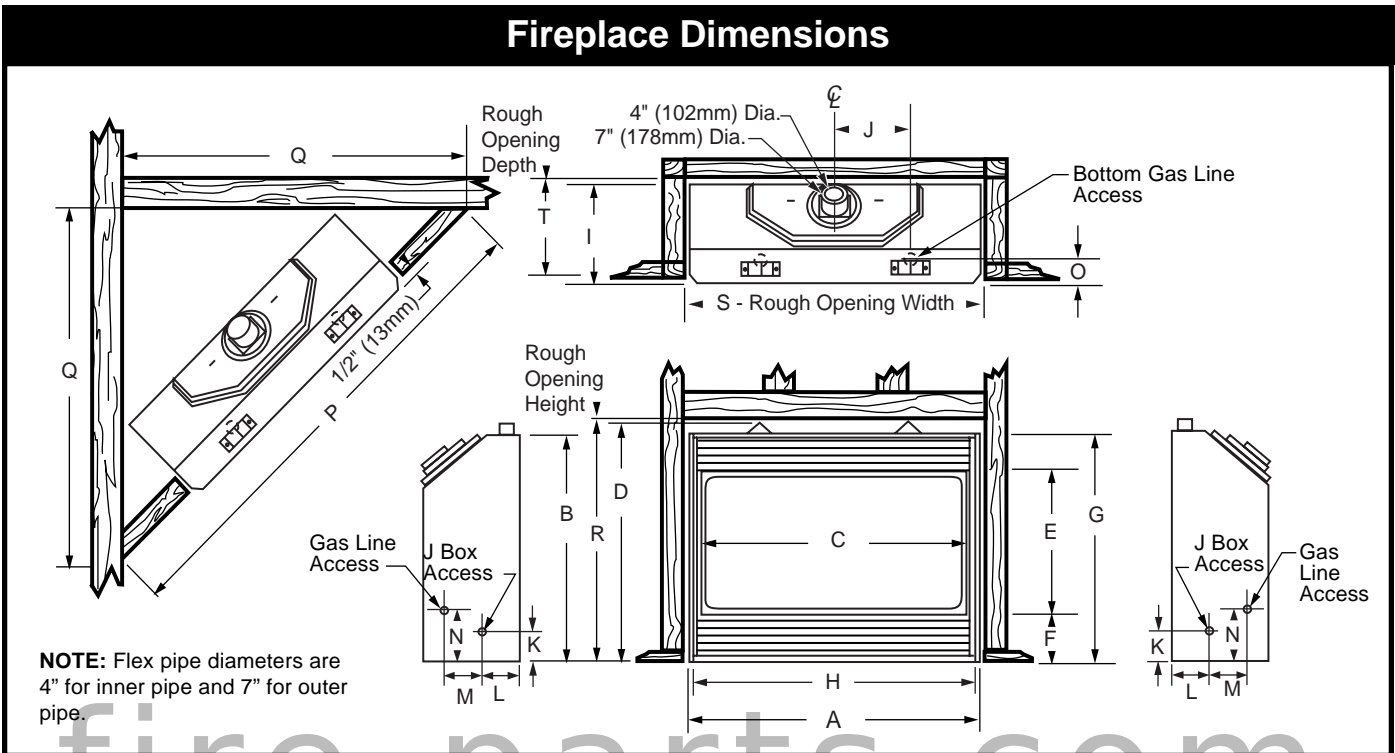

Fig. 2 Fireplace specifications and framing dimensions.

Ref.	DV5200	DV6400
A	35 ³ / ₄ " (908mm)	41 ³ / ₄ " (1061mm)
B	33" (838mm)	33" (838mm)
C	32 ³ / ₄ " (832mm)	38 ³ / ₄ " (984mm)
D	34 ¹ / ₂ " (876mm)	34 ¹ / ₂ " (876mm)
E	21 ³ / ₈ " (543mm)	21 ³ / ₈ " (543mm)
F	6 ¹ / ₄ " (159mm)	6 ¹ / ₄ " (159mm)
G	32" (813mm)	32" (813mm)
H	34 ¹ / ₄ " (870mm)	40 ¹ / ₄ " (1022mm)
I	19 ¹ / ₄ " (489mm)	19 ¹ / ₄ " (489mm)
J	13 ³ / ₈ " (340mm)	13 ³ / ₈ " (340mm)
K	1 ⁵ / ₈ " (41mm)	1 ⁵ / ₈ " (41mm)
L	5 ⁵ / ₈ " (143mm)	5 ⁵ / ₈ " (143mm)
M	5 ¹ / ₂ " (140mm)	5 ¹ / ₂ " (140mm)
N	4 ¹ / ₂ " (114mm)	4 ¹ / ₂ " (114mm)
O	3" (76mm)	3" (76mm)
Framing Dimensions		
P	73 ¹ / ₂ " (1867mm)	79" (2007mm)
Q	51 ³ / ₄ " (1315mm)	56" (1422mm)
R	34 ³ / ₄ " (883mm)	34 ³ / ₄ " (883mm)
S	36" (914mm)	42" (1067mm)
T	Refer to Figure 3 or 4 for Rough Opening Depth	

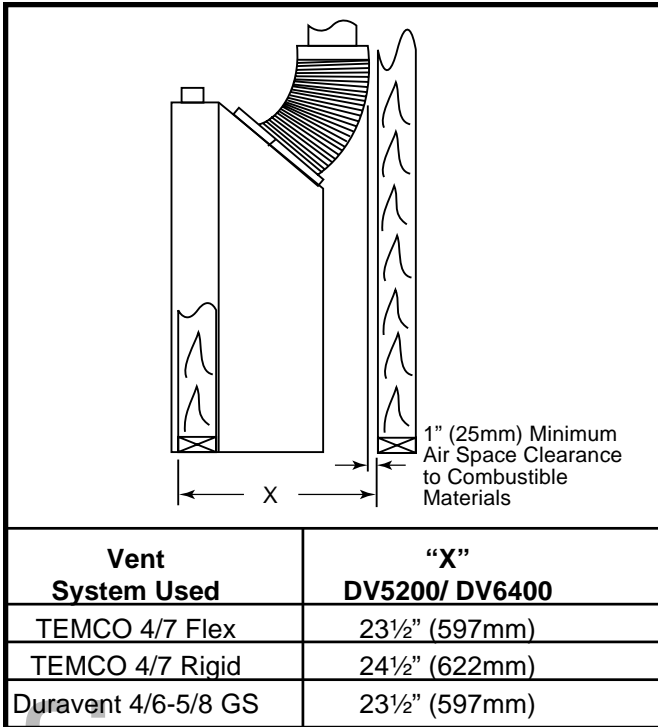

Fig. 3 Minimum framing depths with vertical takeoff.

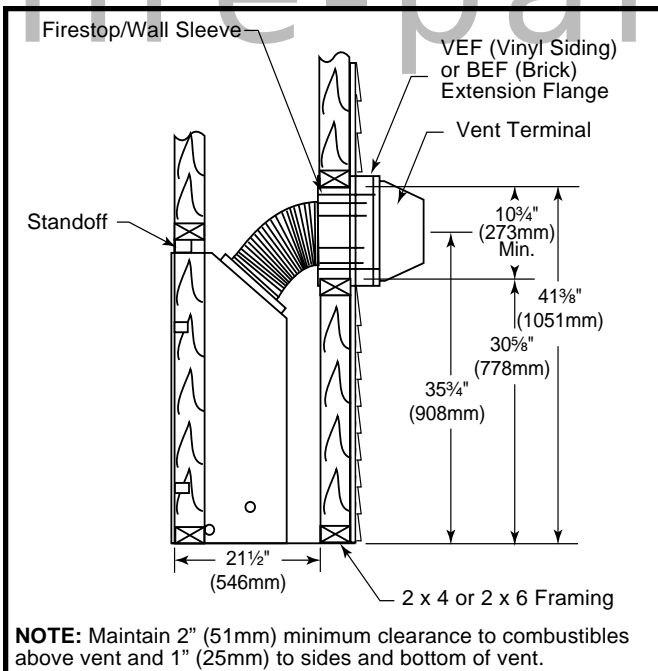

Fig. 4 Minimum framing dimensions with horizontal venting.

Framing and Finishing

1. Choose a fireplace location and frame in accordance with the fireplace dimensions specified on Page 3 of this manual. When using a surround, the fireplace must be flush to the wall. Also, allowances must be made for drywall, tile or any other facing used around the unit.
 2. When the appliance is installed directly on carpeting, tile or other combustible material other than wood flooring, the appliance shall be installed on a metal or wood platform.
 3. Pull out the nail tabs which are located on each side of the fireplace. Move the fireplace into position and secure to the floor with screws or nails through the holes provided in the bottom flanges of the side casing. After checking unit for squareness, secure top of fireplace to the framing with screws or nails using the nailing tabs provided.
 4. Cold climate installation recommendation: when installing this fireplace against a non-insulated exterior wall or chase, it is recommended that the outer walls be insulated to conform to applicable insulation codes. Drywall should be installed around the unit to prevent insulation from contacting the body.
- NOTE: Never let vapor barrier contact the outer case of this fireplace or venting.**
5. Drywall can be extended flush on the bottom, top and to the outermost part of the sides of the fireplace.
 6. Noncombustible materials such as brick and tile can be extended across the face of the fireplace. If brass trim kit is going to be installed, brick and tile will have to be installed flush with the front of this appliance.

Clearance to Combustibles

Top of unit to ceiling* 36" (914mm)
 Front of unit to combustibles 36" (914mm)

Appliance

Top (from standoffs) 0" (0mm)
 Bottom 0" (0mm)
 Side (from standoffs) 0" (0mm)
 Back (from standoffs) 0" (0mm)
 Top of Elbow 2" (51mm)

* Ceiling height is the minimum height of the room ceiling in front of the fireplace measured from the top front edge of the fireplace.

Combustible Sidewall Clearance

The perpendicular combustible sidewall or mantel support leg (surround) clearance is 1 3/4" (45mm) from the edge of the recessed door opening.

Mantels

The height that a combustible mantel is fitted above the fireplace is dependent on the depth of the mantel. For the correct mounting height and widths, refer to Figure 5.

Noncombustible mantels and legs may be installed at any height and width around the appliance. When using paint or lacquer, it must be heat resistant to prevent discoloration.

NOTE: When using paint or lacquer to finish the mantel, such paint or lacquer must be heat resistant (250°F) to prevent discoloration.

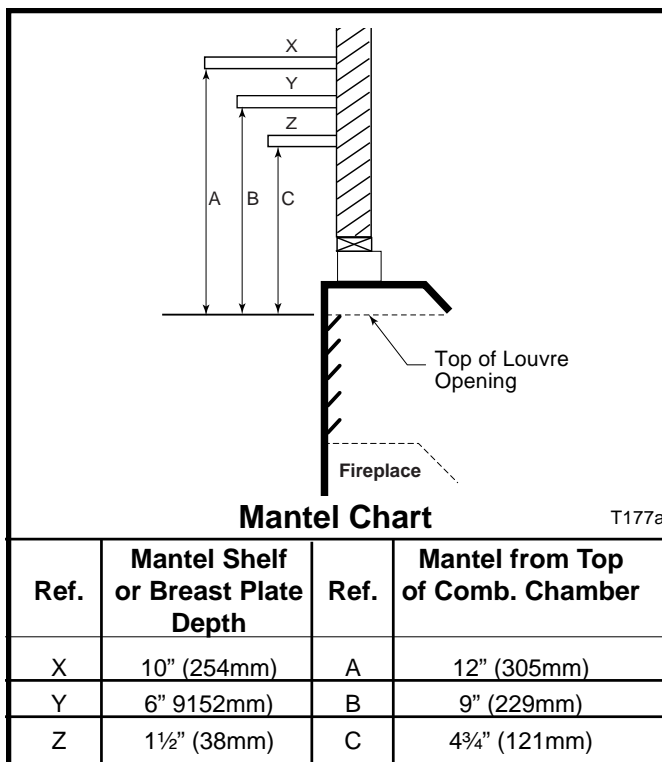

Fig. 5 Combustible mantel minimum installation.

WARNING: Combustible objects must not be placed on a noncombustible mantel unless the noncombustible mantel meets the minimum height and width requirements for a combustible mantel.

Hearth

A hearth is not mandatory but is recommended for aesthetic purposes. We recommend a noncombustible hearth projecting out 12" (305mm) or more in front of the fireplace.

Although a hearth is not mandatory, (as surface temperatures of combustibles are tested) surface temperatures of flooring (carpeting, tile, varnish, etc.) may reach a point where damage to some surfaces may result.

For example:

- carpeting may buckle and discolor
- vinyl tile may discolor and unglue
- varnishes, waxes, etc. on wood flooring may discolor

Surround Material

When using materials around the face of the fireplace, these materials must be suitable to withstand the temperatures which they will encounter. Also these materials must not extend out in front of the face of the unit, in effect recessing the unit.

If the material used for surround is not flush with the face of the unit, then the optional surround kits will not fit properly.

It is recommended that any material used to surround the face of the fireplace be noncombustible (i.e. ceramic tile, brick, natural stone, etc.). Combustible materials such as drywall, are permissible.

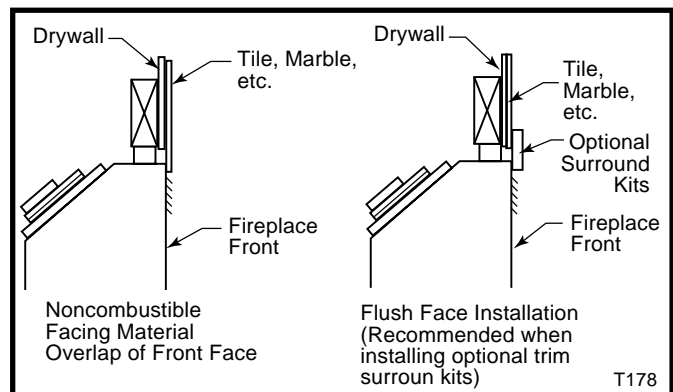

Fig. 6 Surround material options.

Materials such as cultured marble or other synthetic materials are not recommended as they may discolor, warp or create odor as a result of exposure to the temperatures of the front of the fireplace.

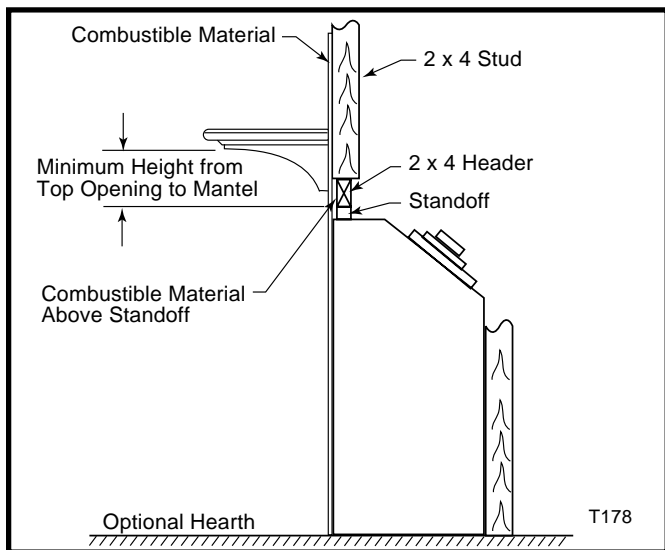

Fig. 7 Gas fireplace installation.

NOTE: Please remember this appliance produces heat. All clearances are to combustible material and are not intended to cover temperatures at which some materials may discolor, warp or produce odor when exposed to temperatures which this unit produces.

Gas Specifications				
Model	Fuel	Gas Control	Max. Input BTU/h	Min. Input BTU/h
DV5200N	Natural	Hi/Lo	25,000	17,000
DV5200P	Propane	Hi/Lo	25,000	17,500
DV6400N	Natural	Hi/Lo	27,000	18,000
DV6400P	Propane	Hi/Lo	25,000	17,500

Gas Inlet and Manifold Pressures		
	Natural	LP (Propane)
Minimum Inlet Pressure	4.5" w.c.	10.8" w.c.
Maximum Inlet Pressure	14.0" w.c.	14.0" w.c.
Manifold Pressure	3.5" w.c.	10.0" w.c.

**DV5200 / DV6400
Certified To
ANSI Z21.88-2000/CSA 2.33--2000/UL 307B
Vented Gas Fireplace Heater**

Gas Line Installation

This gas appliance should be installed by a qualified installer in accordance with local building codes and with current CSA-B149.1 installation codes for Gas Burning Appliances and Equipment in Canada and the National Fuel Gas Code ANSI Z223.1/NFPA 54 in the U.S.A.*

1. The gas pipeline can be brought in through the bottom or the right or the left side of the appliance. A hole is provided at all locations to allow for the gas pipe installation and testing of any gas connection.
2. The gas control inlet is 3/8" NPT. Typical installation layout for rigid pipe is shown on Page 8.
NOTE: All models are equipped with a flex tube with a shut off valve having a 1/2" NPT inlet. The flex line with shut off is shipped in the control valve compartment. Using two wrenches, tighten the flexible tube at the shut off valve and at the gas control.
3. When using a flex connector,* use only approved fittings. When a union is installed, provide easy access in it's placement for servicing. Refer to gas specification for pressure details and ratings.
4. When a vertical section of gas pipe is required for the installation, a condensation trap is needed. In Canada see CSA - B149.1 for code details. See the National Fuel Gas Code ANSI Z223.1/NFPA 54 in the USA.
5. For natural gas, a minimum of 3/8" iron pipe with a gas supply pressure of 4.5" w.c. (from the gas meter). Consult with local gas utility and ANSI223.1/NFPA 54 if any questions arise concerning pipe sizes.
6. Turn the gas supply to 'ON' and check for leaks. **DO NOT USE OPEN FLAME FOR THIS PURPOSE.** Use an approved leak testing solution.
7. The appliance and its appliance main gas valve must be disconnected from the gas supply piping system during any pressure testing of that system at test pressures in excess of 1/2psig (3.5 KPa).
8. The appliance must be isolated from the gas supply piping system by closing its equipment shut off valve during any pressure testing of the gas supply piping system at test pressures equal to or less than 1/2psig (3.5KPa).

NOTE: The gas line connection may be made of 3/8" minimum rigid pipe, 3/8" minimum copper pipe or an approved flex connector. Since some municipalities have additional local codes, it is always best to consult your local authorities and the current CSA-B149.1 installation code in Canada or National Fuel Gas Code ANSI Z223.1/NFPA 54 in the U.S.A.

*Adhere to the following installation requirements in the State of Massachusetts:

- The installer must be a licensed plumber or gas fitter.
- Flex connectors must be Massachusetts approved, cannot exceed 36" (914mm) in length, must be a minimum 1/2" dia., and may not penetrate a wall.

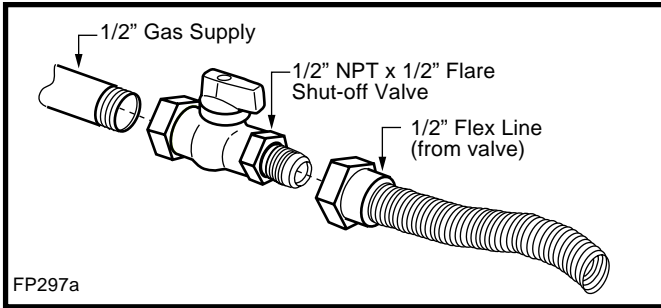

Fig. 8 Typical gas supply installation.

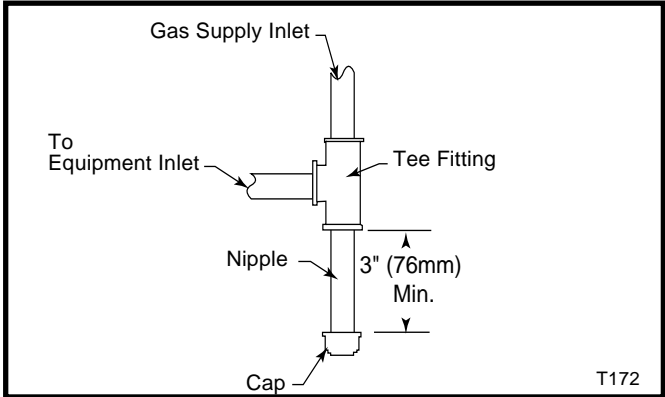

Fig. 9 Sediment trap.

IMPORTANT: Always check for gas leaks with a soap and water solution. Do not use open flame for leak testing.

Sediment Trap

A sediment trap shall be installed as close to the inlet of the equipment as practicable at the time of equipment installation. The sediment trap shall be either a tee fitting with a capped nipple in the bottom outlet as shown below or other device recognized as an effective sediment trap.

Thermostatic Fan Kit - Optional

(Part # GDVTFK)

For installation of the optional fan, please refer to the instructions included in the fan kit.

Electrical Services

Optional fan kits are equipped with a 120V, 60Hz blower, less than 12 amps.

If electrical supply 120V is being roughed in to provide for future installation of an optional blower kit, an approved surface mount, steel electrical box, cover and strain relief bushing must be installed in the fireplace (supplied by others).

NOTE: All electric connections are to be made in accordance with CSA Standard C22.1 - Canadian Electrical Code part 1 or with the National Electrical Code, ANSI/NFPA 70 (latest addition) and/or in accordance with local codes.

General Venting

When locating the vent termination, the minimum vent clearances must be observed. (Page 9, Fig. 10)

NOTE: Local codes may require different clearances.

It is recommended that the termination not be located within 24" (305mm) of garden sheds, fences, decks, utility buildings or other obstructions.

Do not locate termination cap where excessive snow or ice build up may occur. Be sure to check vent termination area after snow falls and clear to prevent accidental blockage of venting system. When using snow blowers, make sure snow is not directed towards vent termination area.

This appliance has a "special vent system". Check with local codes or in the absence of same, with CSA B149.1 installation codes in Canada, or the current National Fuel Gas Code ANSI Z223.1/NFPA 54 in the USA, regarding special vent termination clearances.

These fireplaces are certified for use with four types of venting systems

1. Temco 4" x 7" dia. flex vent.
2. Temco TDV series 4" x 7" dia. rigid vent.
3. Simpson Dura-Vent GS series 4" x 6⁵/₈" dia. vent.
4. Security Secure Vent series 4" x 6⁵/₈" dia. vent.

Review general venting information in this manual, and information packed with the venting prior to starting the installation of the fireplace.

- Termination shall not be recessed into a wall or siding.
- Horizontal sections must maintain a minimum 1/4" rise per linear foot of horizontal run.
- Combustible clearances from any horizontal vent pipe area must be 2" (51mm) from top of vent, and 1" (25mm) from sides and bottom.
- Clearance to combustibles from vertical pipe surface is 1" (25mm).

General Venting Information - Termination Location

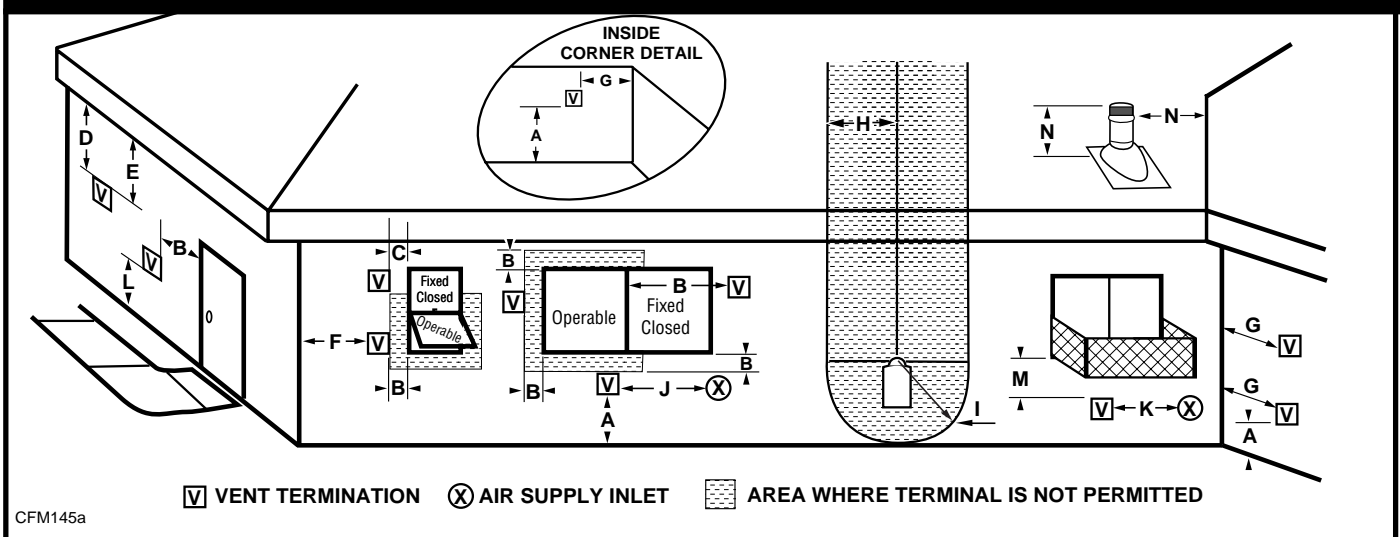

	Canadian Installations ¹	US Installations ²
A = Clearance above grade, veranda, porch, deck, or balcony	12" (30cm)	12" (30cm)
B = Clearance to window or door that may be opened	12" (30cm) for appliances > 10,000 Btuh (3kW) and < 100,000 Btuh (30kW)	9" (23cm) for appliances > 10,000 Btuh (3kW) and < 50,000 Btuh (15kw)
C = Clearance to permanently closed window prevent window condensation	12" (305mm) recommended to prevent window condensation	9" (229mm) recommended to
D = Vertical clearance to ventilated soffit located above the terminal within a horizontal distance of 2 feet (610mm) from the center line of the terminal	18" (458mm)	18" (458mm)
E = Clearance to unventilated soffit	12" (305mm); 30" (762mm) min. for vinyl clad soffit	12" (305mm)
F = Clearance to outside corner	see next page	see next page
G = Clearance to inside corner (see next page)	see next page	see next page
H = Clearance to each inside of center line extended above meter/regulator assembly	3' (91cm) within a height of 15' above the meter/regulator assembly	3' (91cm) within a height of 15' above the meter/regulator assy
I = Clearance to service regulator vent outlet	3' (91cm)	3' (91cm)
J = Clearance to nonmechanical air supply inlet to building or the combustion air inlet to any other appliances	12" (30cm) for appliances > 10,000 Btuh (3kW) and < 100,000 Btuh (30kW)	9" (23cm) for appliances > 10,000 Btuh (3kW) and < 50,000 Btuh (15Kw)
K = Clearance to a mechanical air supply inlet	6' (1.83m)	3' (91cm) above if within 10' (3m) horizontally
L = Clearance above paved sidewalk or paved driveway located on public property	7' (2.13m)†	7' (2.13m)†
M = Clearance under veranda, porch, deck or balcony	18" (46cm)‡	18" (46cm)‡
N = Clearance above a roof shall extend a minimum of 24" (610mm) above the highest point when it passes through the roof surface, and any other obstruction within a horizontal distance of 18" (450mm).		

1 In accordance with the current CSA-B149 Installation Codes
 2 In accordance with the current ANSI Z223.1/NFPA 54 National Fuel Gas Codes
 † A vent shall not terminate directly above a sidewalk or paved driveway which is located between two single family dwellings and serves both dwellings
 ‡ only permitted if veranda, porch, deck or balcony is fully open on a minimum 2 sides beneath the floor:
 NOTE: 1. Local codes or regulations may require different clearances.
 2. The special venting system used on Vermont Castings Direct Vent Stoves are certified as part of the appliance, with clearances tested and approved by the listing agency.

Fig. 10 Vent termination clearances.

NOTE: Use only venting systems and components as certified with the appliance. Use of uncertified vent systems or components will void the warranty and may compromise the operation of the fireplace, its systems, and components as certified with the appliance.

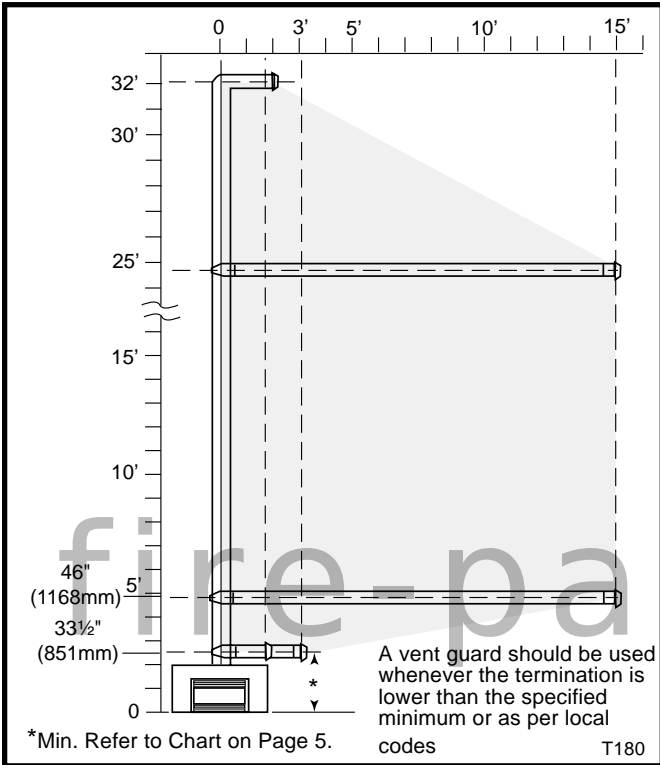

Fig. 11 Venting graph.

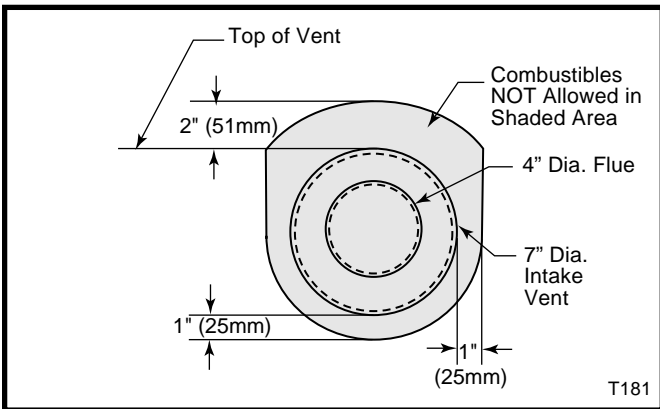

Fig. 12 Vent clearances.

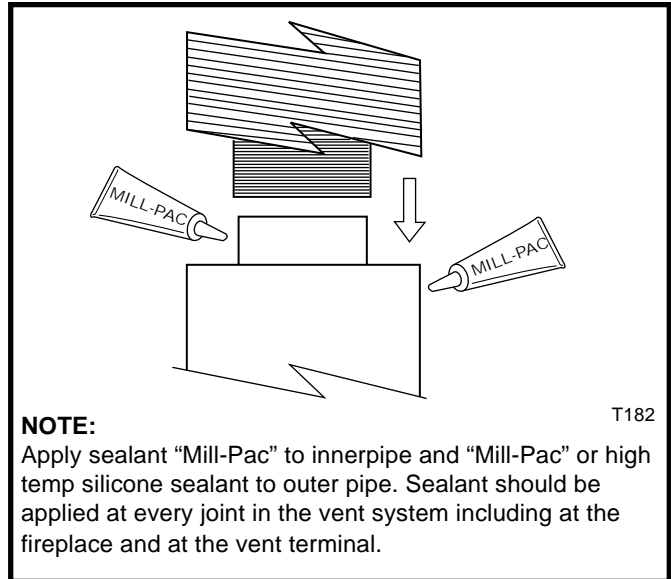
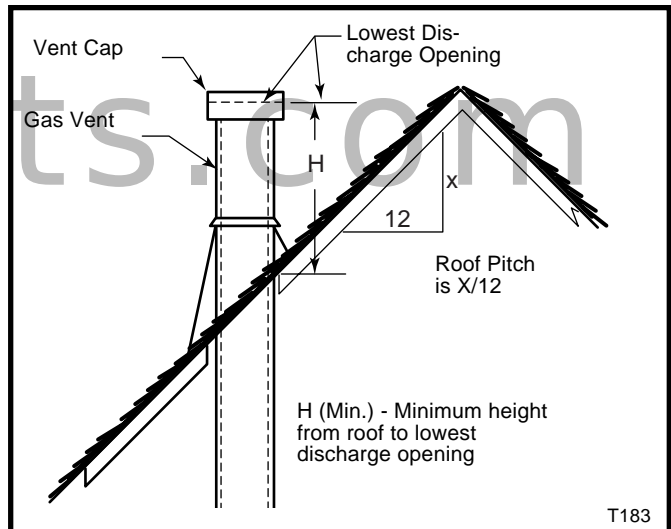

Fig. 13 Apply sealant at every joint in vent system.



Roof Pitch	H (Min.)
Flat to 6/12	12" (305mm)
6/12 to 7/12	15" (381mm)
Over 7/12 to 8/12	18" (457mm)
Over 8/12 to 16/12	24" (610mm)
Over 16/12 to 21/12	36" (914mm)

Fig. 14 Vertical termination location.

Sidewall (General) Venting Information

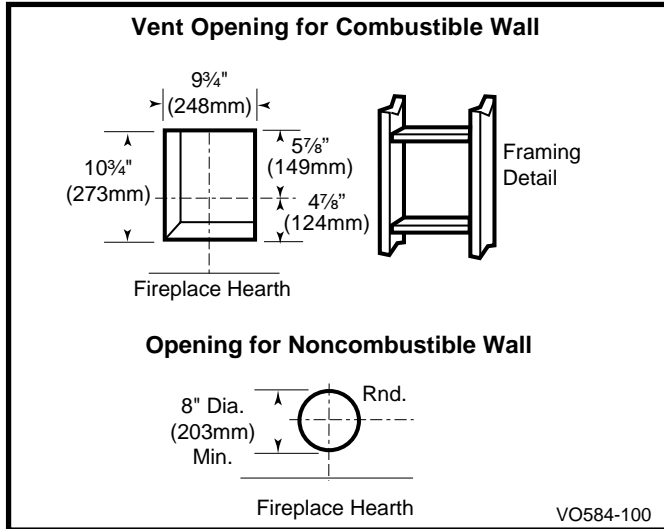

Fig. 15 Locate vent opening on wall.

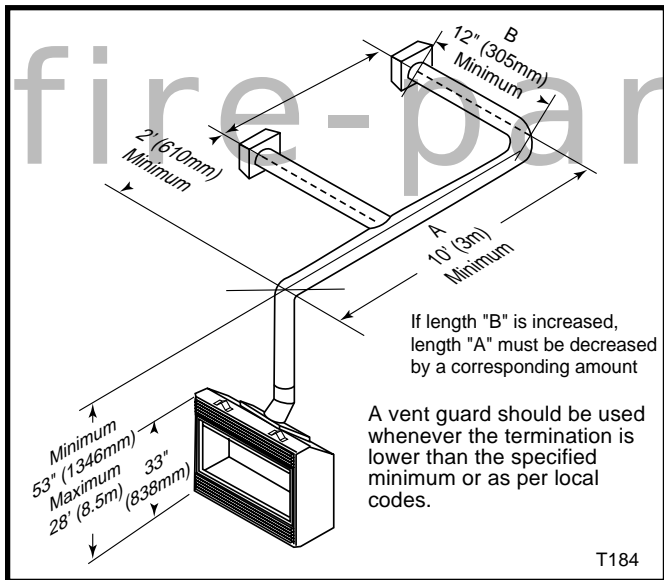

Fig. 16 Horizontal vent run.

Figures 15 and 16 show examples of horizontal termination arrangements using two 90° elbows (Rigid Vent).

NOTE:

1. A maximum of two 90° elbows are permitted.
2. A minimum of 10' (3m) vertical from base of unit is required if two 90° elbows are used.
3. Minimum distance between elbows is 2' (610mm).
4. Determine the permitted range of horizontal termination arrangement by using chart above and deducting 3' (914mm) from the maximum horizontal distance for the second 90° elbow.

Flex Venting

Refer to Page 19 for venting components list.

- Flex vent shall use the spacer springs as included every foot to ensure proper vent operation.
- The 4" x 7" flex system may be used for all sidewall applications and vertical venting up to 35' (10.7m).
- Flex shall be properly supported so there are no sags in the system. Supports must be used at least every 24" (610mm) on horizontal section and every 36" (914mm) on vertical. Wire or metal stripping may be used to support the venting.
- For 4" x 7" flex, the 7" flex has an outside diameter of 7 1/2" (191mm) and if installed in a chase the inside diameter of the chase should be 9 1/2" (241mm) minimum.
- Lengths of co-axial flex may be joined together using a flex connector kit (GFPVCK) only, maximum 1 kit per installation.

An extension collar is included with side wall cap kits to simplify the connection of the flex pipe to the fireplace. Refer to Page 13, Figure 22.

ATTENTION: Spacer springs must be installed when installing flexible venting systems.

Wrap spacer spring around flex flue pipe and overlap spring ends approximately 2" (610mm). Tie one end over the other like a shoelace tie, then reverse direction of spring ends. Lift up hooped spring and slide both spring ends underneath hooped spring. Spring spacers should be spaced at approximately 12" (305mm) intervals for the length of pipe system. Once the springs are placed around the flue pipe, slide the flue section with spacer springs into the outer flex pipe.

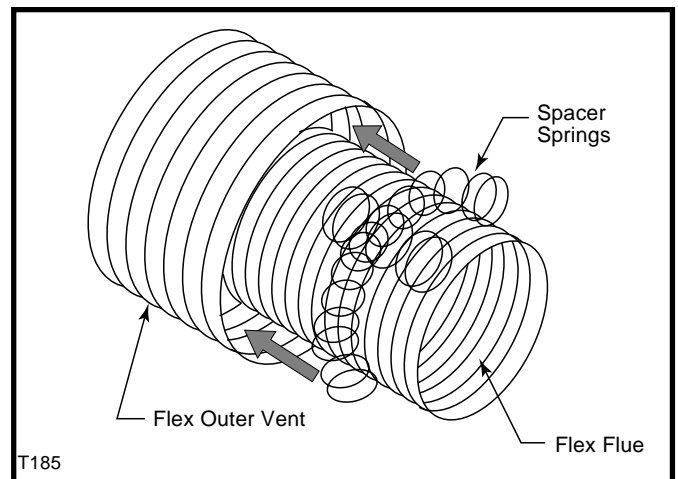

Fig. 17 Wrap spacer spring around flex flue pipe, overlapping ends.



CAUTION: Care must be taken when tightening clamps so the flex does not tear at clamp location.

Sidewall (Horizontal) Venting

For side wall (Horizontal) venting, this appliance is approved for use with a 7" x 4" flexible venting system with spacers.

Clearance to combustible material from the pipe is 1" (25mm). Sides and bottom, 2" clearance from the top. Note: O.D. of pipe is 7½" (191mm).

Horizontal Vent Kits

◆ CDV-HSK (Round Termination Cap)

The vent starter kit contains the following:

- Horizontal termination
- Wall thimble
- 36" of 7" x 4" flex with spacers and clamps.
- Extension collar

◆ HFTK (Trapezoid Termination Cap)

The vent starter kit contains the following:

- Horizontal termination
- Wall thimble
- Extension collar

NOTE: HIGH WIND AREAS All termination caps are tested and certified for wind conditions up to 40 mph (64 k/h).

A Vinyl Extension Frame Kit No. VEF is required for all installations where vinyl siding is used with the HFTK Kit or HSQ47 Horizontal Vent Termination. If a Vinyl Extension Frame Kit No. VEF is used, measure to outside surface of wall without siding and add 2 additional inches (51mm) to the venting length.

A brick extension kit No. BEF is available to extend the horizontal vent terminal HSQ47 or HFTK kit terminal beyond the brick surface. If the BEF extension is used, measure to the outside surface of the framed wall and add 4 additional inches to the venting length.

Flex Vent Offsets

Each installation assumes the use of (1) 45° (bend) starting off top of unit.

To determine the amount or length of flex vent you need for a given installation, add the total offset dimension to the total rise needed. Then add 1 ft. (305mm) for every 45° bend and/or 2' (610mm) for each 90° bend.

No more than (4) 90° and (2) 45° offsets are to be used per installation. Vent terminal cap location should be in accordance with the Venting Graph chart and the Vertical Termination Location information.

1. Measure the total wall thickness. Determine whether or not the thimble extension is needed. If the combustible wall depth is over 5" (127mm), the extension should be used. (Fig. 19)

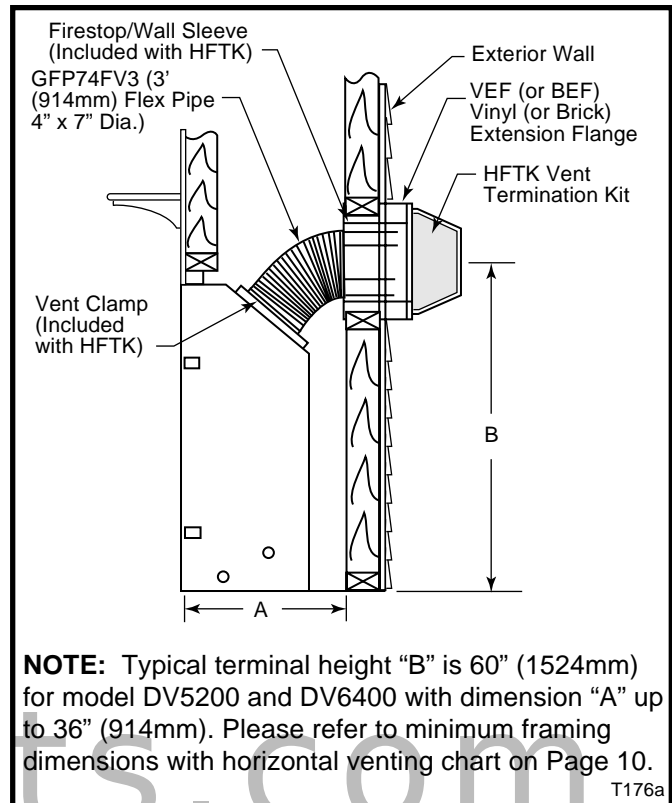

Fig. 18 Typical direct vent gas fireplace with horizontal venting.

2. Assemble wall thimble with thimble extension flange to top. Mate thimble to wall plate with the four tabs provided. Bend tabs over to secure. (Fig. 19)
3. Install the wall thimble assembly through the framed opening so the firestop plate is on the interior wall. (Fig. 20) Telescope section should extend all the way through wall.

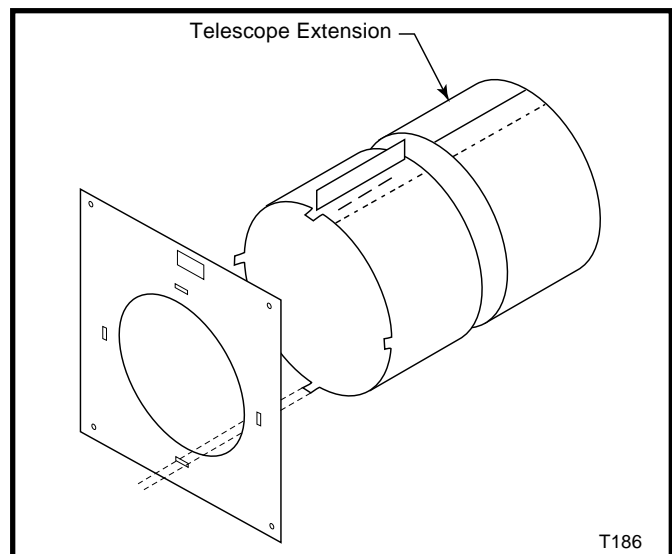

Fig. 19 The telescope extension must be used if wall thickness is over 5" (127mm).

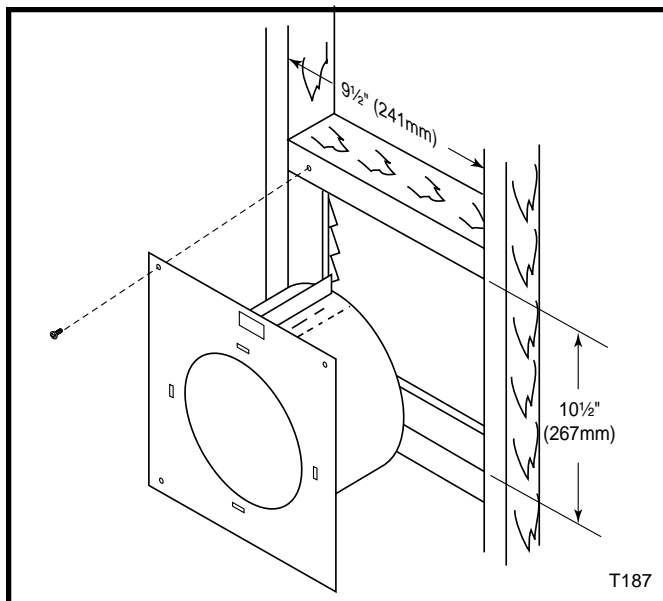

Fig. 20 Install wall thimble with firestop on interior wall.

4. Step 1: Apply Mill-Pac to 4" flue inner pipe on cap.
 Step 2: Connect 4" flex flue to flue on cap with band clamp.
 Step 3: Apply silicone sealant or mill-pac to 7" outer pipe on cap.
 Step 4: Slide 7" outer flex over inlet and secure with band clamp.
5. Secure vent cap terminal to exterior wall with screw type fasteners as needed. (Fig. 21)
6. Connect corrugated side of the extension collar (7" dia.) into the 7" dia. flex pipe. (Fig. 22) Place a small bead of sealant around the collar approximately 1/4" from the leading edge of the corrugation. Insert the collar firmly into the flex pipe and secure with the provided (7" dia.) band clamp.
7. Place a small mill-pac bead around the top edge of the fireplace flue collar. Then, attach the flex tube over the flue collar with a 4" dia. band clamp.
8. To finish connections, place a small bead of sealant to the outside of the fireplace inlet flange. Then, slide the extension collar over the inlet flange and secure with the three (3) screws provided.

NOTE: We recommend driving in two (2) sheet metal screws at 180° adjacent to the gear clamp at each joint.

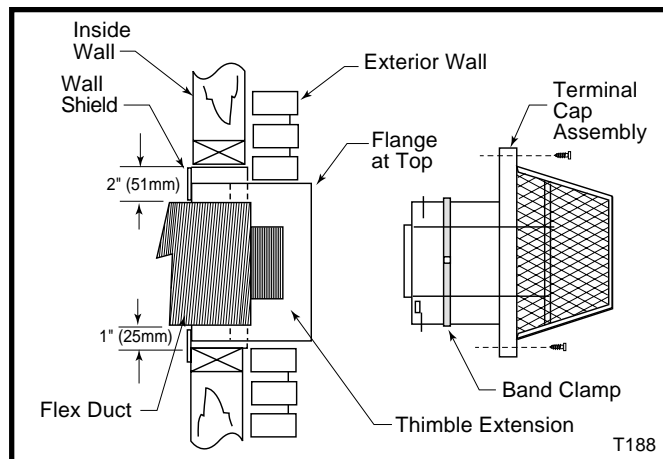

Fig. 21 Secure vent cap terminal to exterior wall.

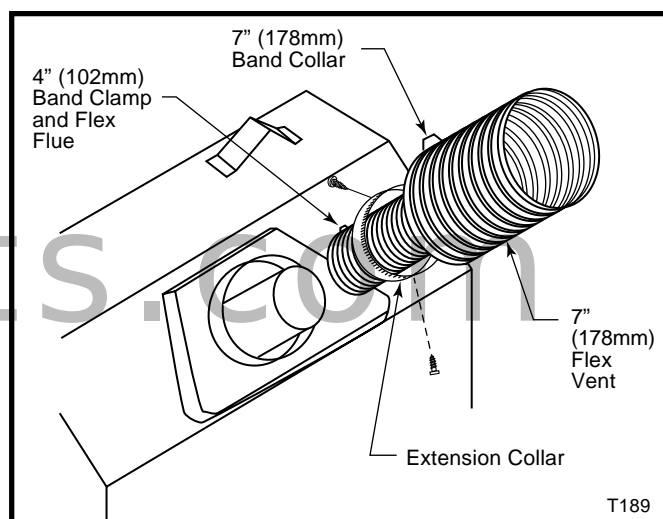

Fig. 22 Insert collar into flex pipe and secure with band clamp.

ATTENTION: Spacer springs must be installed when installing flexible venting system.

Flex Vent Through the Roof (Vertical) Applications

All models are approved for:

1. Vertical venting up to 35' (10.7m) with 7" x 4" flex.
2. Multiple bends allowed. See section on General Venting.
3. With each vertical installation, a VSK7MH-2 kit may be used.

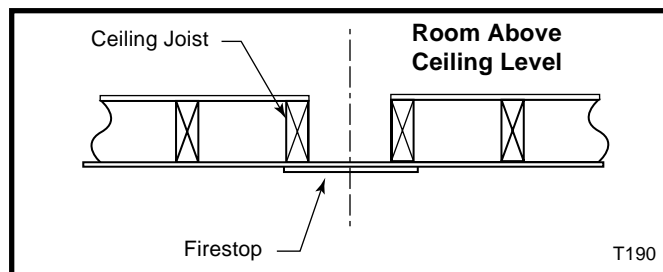

Fig. 23 Firestop at ceiling level.

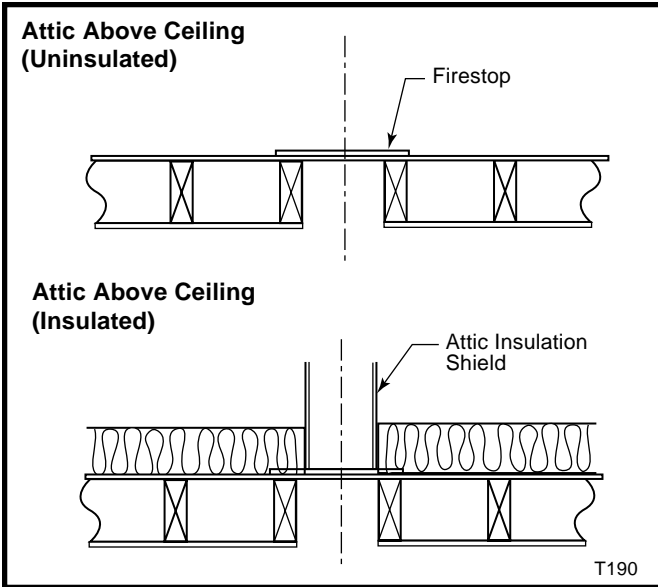

Fig. 24 Attic insulation shield.

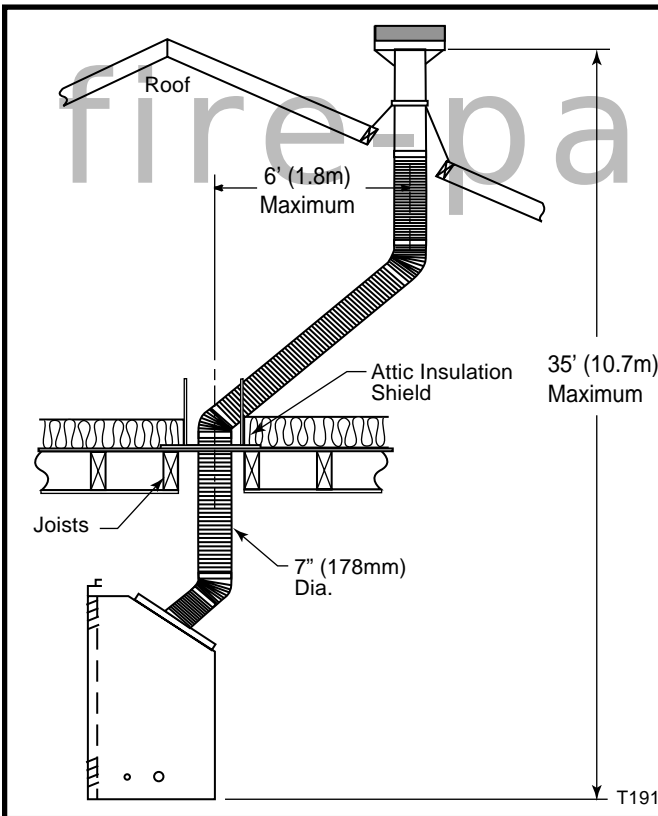

Fig. 25 Typical through-the-roof installation.

The VSK7 Kit contains:

- Vertical Termination Cap and Storm Collar
- 4" / 7" dia. x 24" Rigid Pipe (unitized)
- 7" dia. Roof Support Components
- 0/12-5/12 Flashing with Storm Collar
- Tube High Temp Sealant
- 7" dia. Inlet Ext. Collar
- Firestop
- Hardware Pack
- Instruction

VSK7 Vertical Flex Vent Kit Installation

1. Locate the fireplace.
 2. Mark ceiling above unit where flex will come through.
- *-REFER TO VERTICAL TERMINATION LOCATION CHART**
3. Ceiling opening should be a minimum of 9 1/2" x 9 1/2" (241 x 241mm) and framed to that size.
 4. Mark opening in roof and cut a hole minimum 9 1/2" x 9 1/2" (241 x 241mm) and frame to that size.
 5. Place fireplace in proper location and secure to the floor.
 6. Install the firestop at the ceiling level.
 7. If an attic space (insulated or not) is located above the ceiling, the firestop should be installed to the underside of the ceiling. The firestop maintains the proper air-space clearance from the vent to insulation and building materials. An attic insulation shield (AS7-8) may be used above the firestop to keep attic insulation spaced away from the vent system.
 8. Rigid pipe section included with vertical termination must be used in conjunction with the roof support so that the termination is secure in winds. All vent kit components can be assembled on the ground first, then lift complete assembly onto the roof and feed flex vent down thru the roof opening and firestop thimble assembly. Then trim off unneeded flex at unit and make the connection at the fireplace flue and inlet collars. Make sure vent cap will be in accordance with the vertical termination location chart. Install the roof flashing below the shingles across the top half, and above the shingles on the lower half.
 9. Install storm collar and caulk around the pipe.

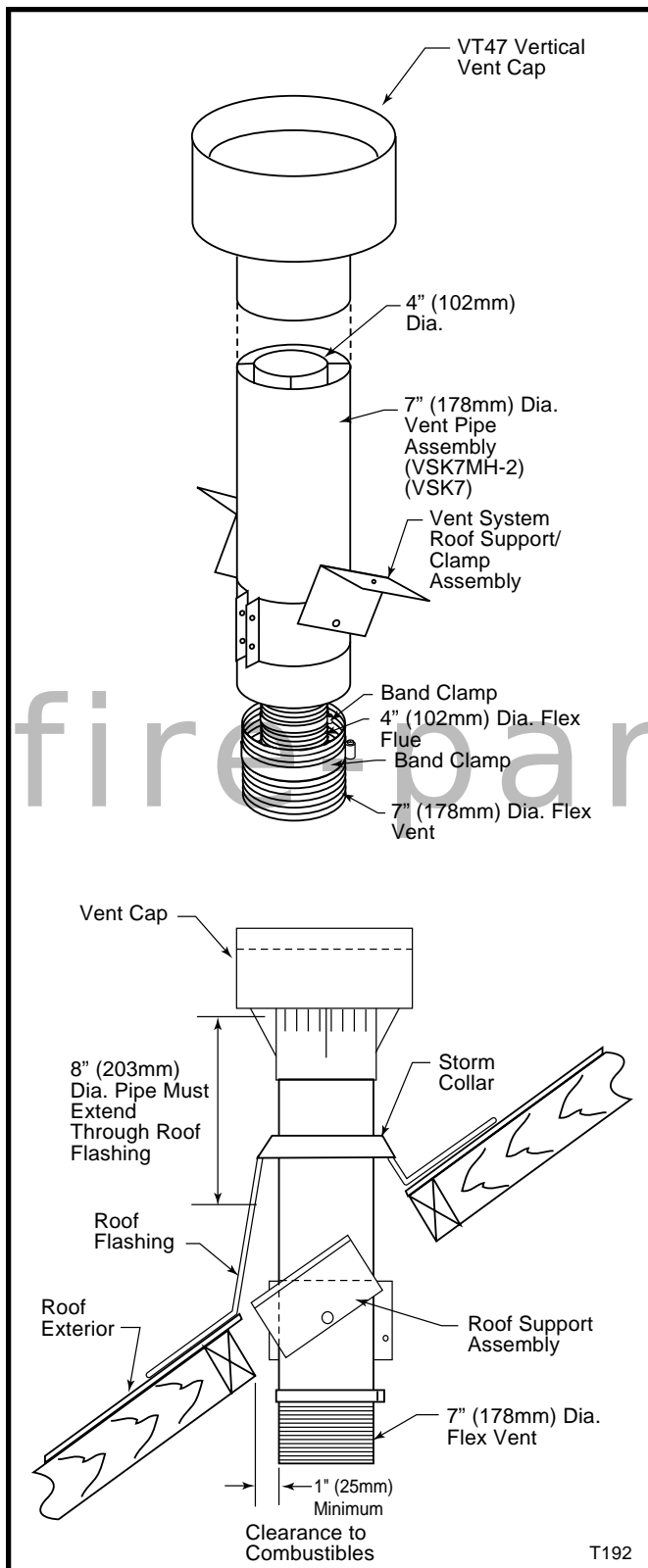

Fig. 26 Through the roof installation.

NOTE: If offset is required, the upper 45° bend (elbow) must be supported with an offset support. Support flex every 3' (914mm) when vertical venting.

TDV Series Direct Vent System Installation

Refer to Page 19 for venting components list.

- The TDV series vent system is specifically approved only for Temco Direct-Vent fireplace models with a 4" (102mm) diameter flue and a 7" (178mm) diameter inlet vent system. The use of uncertified venting will void warranties and may compromise the operation and safety of the appliance.
- Termination shall not be recessed into a wall or siding.
- The vent system shall be properly supported so there are no sags in the system. Supports must be used at least every 3' (914mm) on horizontal section and every 6' (1.8m) on vertical.
- Horizontal sections must maintain a minimum 1/4" rise per linear foot of horizontal run.
- Combustible clearances from any horizontal vent pipe area must be 2" (51mm) from top of vent, and 1" (25mm) from sides and bottom.
- Clearance to combustibles from vertical pipe surface is 1" (25mm).
- Prior to securing each vent component, make sure the sections are pushed together firmly to maintain vent integrity.

Sidewall (Horizontal) Venting, General

When locating the vent termination, the minimum vent clearances must be observed.

NOTE: Local codes may require different clearances.

It is recommended that the termination not be located within 24" (610mm) of garden sheds, fences, decks, utility buildings or other obstructions.

Review the "vent termination" section in the appliance installation instructions.

Do not locate vent terminal where excessive snow or ice build up may occur. Be sure to check vent termination area after snow falls and clear to prevent accidental blockage of venting system. When using snow blowers, make sure snow is not directed towards vent termination area.

The TDV series is considered a "special vent system". Check with local codes or in the absence of same, with CSA B149.1 installation codes regarding special vent termination clearances.

NOTICE: Flexible and rigid vent system components are not interchangeable unless otherwise specified in the venting instructions.

NOTICE: Additional venting information regarding clearances, terminal locations, and safety information is contained in the installation and operating instructions packaged with the appliance.

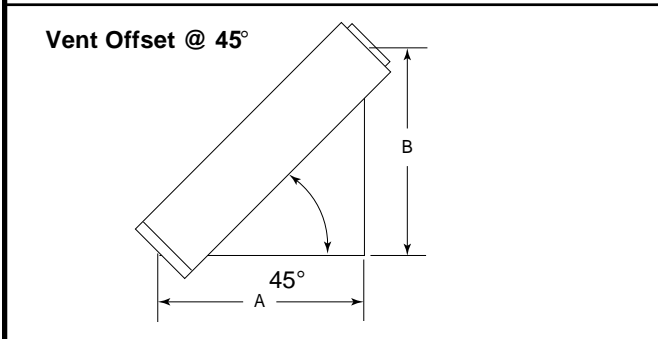
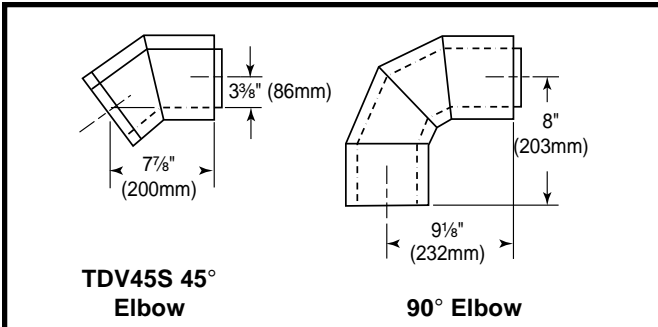

Vent Pipe Component	Installed True Length Gain	"A" Rise	"B" Run
TDV6	4" (102mm)	2 1/16" (68mm)	2 1/16" (68mm)
TDV12	10" (254mm)	7 1/16" (179mm)	7 1/16" (179mm)
TDV18	16" (406mm)	11 5/16" (287mm)	11 5/16" (287mm)
TDV36	34" (864mm)	24 1/16" (611mm)	24 1/16" (611mm)
TDV48	46" (1168mm)	32 1/2" (826mm)	32 1/2" (826mm)



IMPORTANT: Do not mix vent system components with components for other vent systems.

Note: Use only venting systems and components as certified with the appliance. Use of uncertified vent systems or components will void the warranty and may compromise the operation of the fireplace, its systems, and components as certified with the appliance. Use of uncertified vent systems or components will void the warranty and may compromise the operation of the fireplace.

Through the Roof (Vertical) Venting

When the venting penetrates a roof the system must be installed in accordance with the current CSA B149.1 installation code (in Canada) or the current National Fuel Gas Code, ANSI Z223.1/NFPA 54 (in U.S.A.). SEE CHART FOR VERTICAL TERMINATION LOCATION.

Elbows & Offsets - General

Each installation assures the use of one 45° elbow horizontal or vertical (off top of unit).

Sidewall (Horizontal) Venting Information

1. Make sure fireplace location and termination location are consistent with requirements for terminations and vent runs.
2. Secure unit to the floor.
3. Locate vent opening in wall. Maintain 2" (51mm) clearance to top of vent from combustibles. Install wall thimble per instructions supplied with Horizontal Vent Kit. Refer to Pages 12 & 13, Figures 19 and 20 for wall thimble installation.
4. Attach vent components beginning with a TDV45S elbow. Apply high temperature sealant to the outside leading edge of the fireplace flue pipe, then install the TDV45S starter elbow and secure it to the fireplace with the three (3) screws (provided) through the outer pipe flange and into the fireplace 7" (178mm) dia. starter flange.

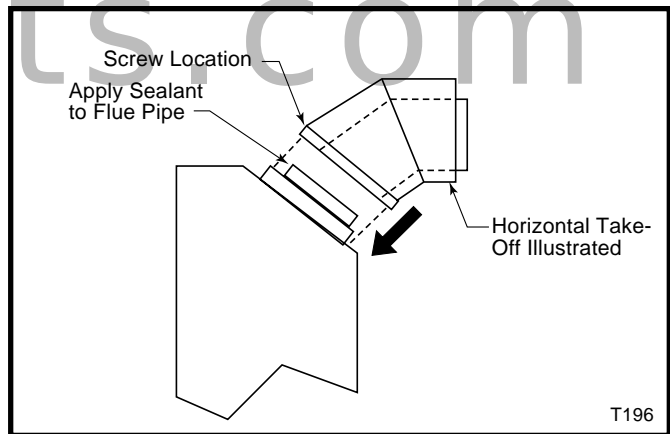

Fig. 27 Apply high temperature sealant to outside of flue pipe.

5. Align the flue and inlet pipes of each vent section to the mating component, then slide the sections together. Before a joint in the system is secured, push the vent components together using moderate force to ensure joint overlap of approximately 1 1/2" (38mm).
6. Secure vent components with a minimum of three (3) screws at each joint (pipe joint to pipe, joint sealants are not required). Never use screws in vent systems longer than 1" (25mm).
7. Vent sections and elbows may be rotated 360° prior to securement to obtain the desired direction of vent run, and provide flexibility.
8. Make sure all horizontal sections have no sags and maintain a minimum 1/4" (6mm) rise per linear foot.

9. Using the high temperature sealant provided, apply a small bead of sealant to both the flue and inlet pipe extensions on the vent terminal (cap) and install the horizontal vent terminal to side of building with four (4) screws provided.
10. If the last section of vent pipe does not allow the vent terminal to seat against the outside wall, it will be necessary to replace the last vent section with a shorter vent section. In addition, you may also measure the distance between the wall and back flanges of the terminal base plate. Next, trim off the terminal flue and inlet pipes to the dimension measured and reinstall the vent terminal.

ATTENTION: Vent terminal flue and inlet pipes must overlap last vent section a minimum of 1" (25mm).
 If the horizontal termination is located in an accessible area below 7" (178mm), an HTG guard is to be installed over terminal.

A Vinyl Extension Frame Kit No. VEF is required for all installations where vinyl siding is used with the HFTK Kit or HSQ47 Horizontal Vent Termination. If a Vinyl Extension Frame Kit No. VEF is used, measure to outside surface of wall without siding and add an additional 2" (51mm) to the venting length.

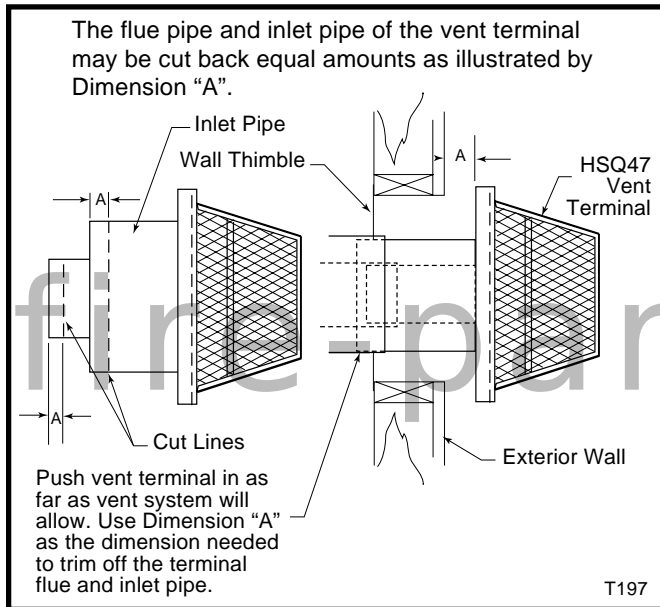

Fig. 28 Cut the terminal flue and inlet pipes to shorten the vent section.

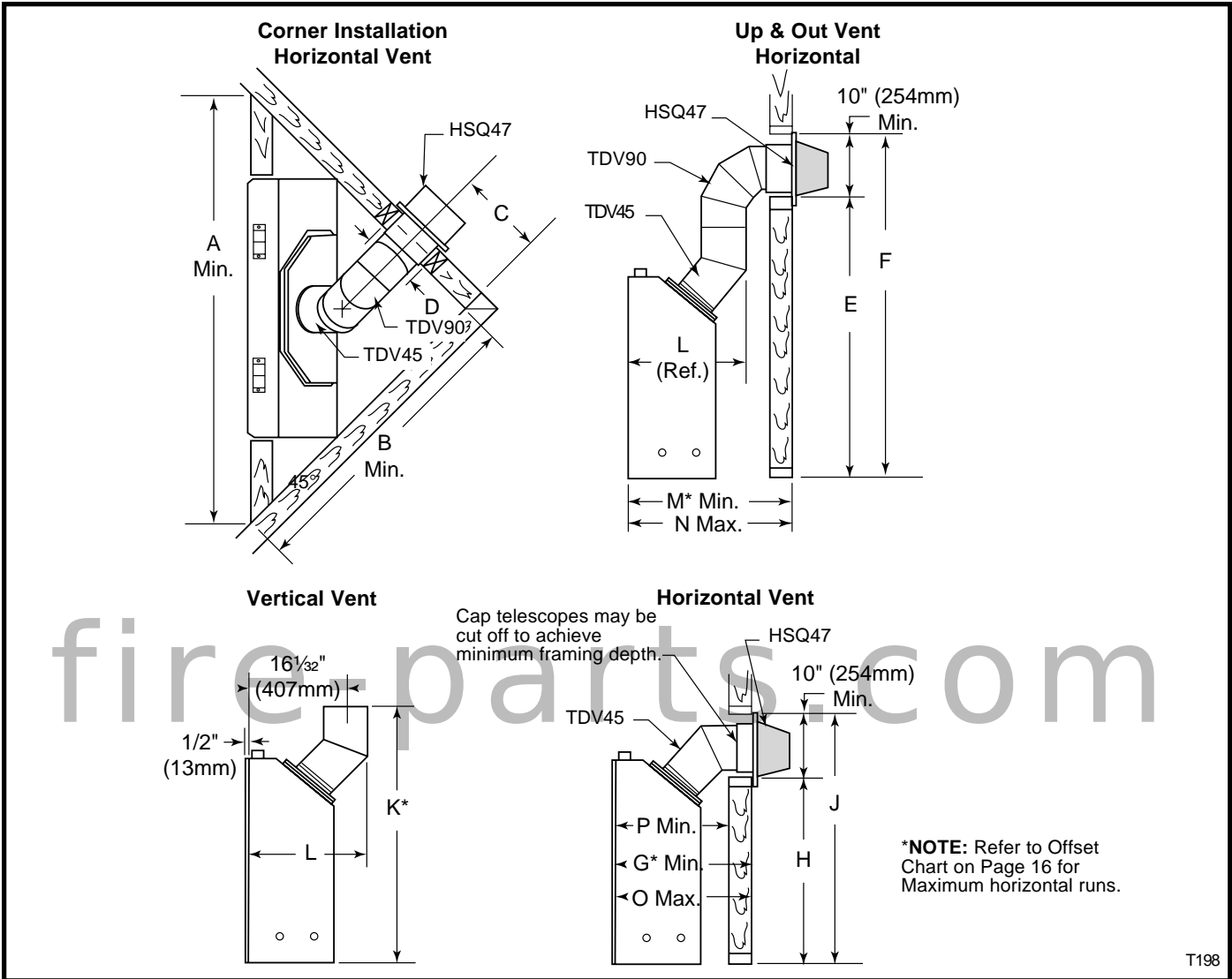
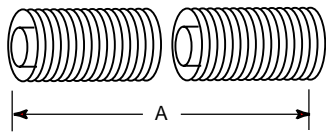

Fig. 29 Typical TDV Series vent applications.

Ref.	DV5200	DV6400
A	73½" (1867mm)	79" (2007mm)
B	51¾" (1315mm)	55⅞" (1419mm)
C	12" (305mm)	14¼" (362mm)
D	9⅞" (240mm)	9⅞" (240mm)
E	42½" (1080mm)	42½" (1080mm)
F	53¼" (1353mm)	53¼" (1353mm)
G	24" (610mm)	24" (610mm)
H	30⅝" (778mm)	30⅝" (778mm)
J	41⅜" (1051mm)	41⅜" (1051mm)
K	39⅜" (1000mm)	39⅜" (1000mm)
L	23½" (597mm)	23½" (597mm)
M	29¼" (743mm)	29¼" (743mm)
N	34" (864mm)	34" (864mm)
O	28½" (724mm)	28½" (724mm)
P	20½" (521mm)	20½" (521mm)

Flexible Venting Individual System Components



Vent Kit	A
GFP74FV3	3' (914mm)
GFP74FV10	10' (3m)
GFP74FV20	20' (6m)
GFP74FV30	30' (9m)

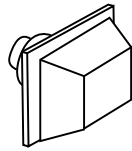

HFTK
Horizontal Flex
Terminal Kit
(76478)



SC7
Storm Collar
(Used with 7" dia.
pipe system only)
(76050)

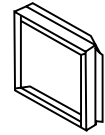

VEF
Vinyl Extension Frame
Kit
(For use with HFTK)

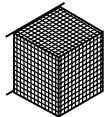

HTG
Horizontal
Terminal
Guard Kit
(75783)



AS7-8
Attic Insulation
Shield (76093)

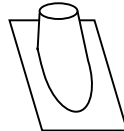

RF7612
Roof Flashing
(6/12 - 12/12)
(Used with 7" dia. pipe
system only) (76049)

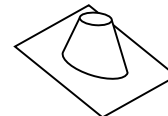

RF705
Roof Flashing
(0/12 to 5/12)
(Used with 7" dia. pipe
system only) (76048)

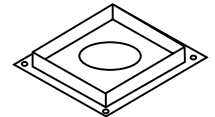

GFP7FS
Firestop
Spacer

T199

Temco Flex Vent Termination Kits Available

Square Horizontal Cap (uses 7/4 Flex)	HFTK
Round Hor. Term. Cap (High Wind) (Includes 7/4 Flex x 3 ft. long)	CDV-HSK
Round Hor. Term. Cap (uses 7/4 Flex)	RN47
Vertical Vent Kit (Includes 7/4 flex x 10 ft. long, Firestop Thimble Assy)	VSK7MH-2
Vertical Vent Kit (uses 7/4 Flex)	VSK7

TDV Series Direct-Vent System Installation



TDV45S
Elbow



TDV90
Elbow

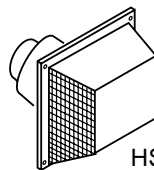

HSQ47
Horizontal Vent Terminal
(Includes Wall Thimble)
(75915)

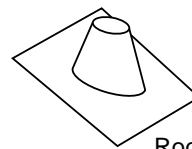

RF705
Roof Flashing
0/12 to 5/12
(76048)

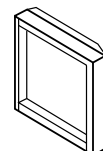

VEF
Vinyl
Extension
Frame
for use with
HSQ47

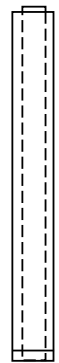

TDV48

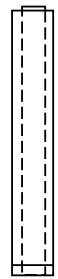

TDV36



TDV18

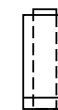

TDV12



TDV5

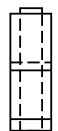

TDV1218
Adjustable
Vent



SC7
Storm Collar
(76050)

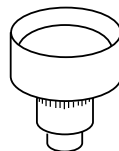

VT47
Vertical Vent
Terminal
(75909)



AS7-8
Attic Insulation
Shield (76093)

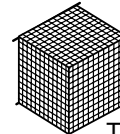

HTG
Horizontal
Terminal
Guard
Kit
(75783)

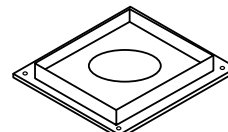

FS7
Firestop Spacer
(76094)

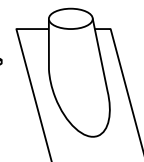

RF7612
Roof Flashing
(6/12 to 12/12)
(76049)

T204

NOTE: Flexible and rigid vent system components are NOT interchangeable unless otherwise specified in the venting instructions.

**Simpson Dura-Vent Venting
Horizontal or Vertical Terminations**

Refer to Page 21 for venting components list.

The Simpson Dura-Vent Direct Vent System (GS 4" x 6 5/8") offers a complete line of component parts for installation of both horizontal and vertical installations. Many items are offered in decorative black, as well as galvanized finish. The galvanized finish may be used for installation with your Temco gas fireplace.

The minimum components required for a basic horizontal termination are:

- 1 Horizontal Termination Cap
- 1 Flue Adapter (45° Elbow)
- 1 Wall Penetration Heat Shield
- 1 Length of pipe to suit wall thickness (see chart)

Wall thickness is measured from the back of the fireplace to the inside mounting surface of termination cap. For siding (other than vinyl) furring strips may be used, instead of the vinyl siding standoff, to create a level surface to mount the vent terminal. The Terminal must not be recessed into siding. Measure the wall thickness including furring strips.

If a Vinyl Siding Standoff is required (it must be used with vinyl siding), measure to outside surface of wall without siding and add 2" (51mm).

Flat Wall Installation (All Units)	
Wall Thickness inches (mm)	Vent Length Required (inches(mm))
5½" - 7" (140 - 178mm)	- -
9½" - 11" (241 - 279mm)	6" (152mm)
12½" - 14" (318 - 356mm)	9" (229mm)
15½" - 17" (394 - 432mm)	12" (305mm)
14½" - 19⅝" (368 - 499mm)	11" - 14⅝" Adj. Pipe (279 - 372mm)
20½" - 29" (520 - 737mm)	17" - 24" Adj. Pipe (432 - 610mm)
Corner Installation (DV5200)	
2¾" - 3⅞" (56 - 94mm)	6" (152mm)
5¾" - 6⅞" (132 - 170mm)	9" (229mm)
8¾" - 9⅞" (208 - 246mm)	12" (305mm)
9¾" - 10⅞" (233 - 272mm)	6" + 9" (152 + 229mm)
12¾" - 13⅞" (310 - 347mm)	6" + 12" / 9" + 9" (152 + 229mm) / (229 + 229mm)
13¾" - 21⅞" (335 - 551mm)	17" - 24" Adj. Pipe (432 - 610mm)
7¾" - 12⅞" (183 - 313mm)	11" - 14⅝" Adj. Pipe (279 - 372mm)
Corner Installation (DV6400)	
7⅞" - 8⅞" (181 - 219mm)	6" + 9" (152 + 229mm)
10⅞" - 11⅞" (257 - 295mm)	6" + 12" / 9" + 9" (152 + 229mm) / (229 + 229mm)
11⅞" - 19⅞" (283 - 499mm)	17" - 24" Adj. Pipe (432 - 610mm)
5⅞" - 10¼" (130 - 260mm)	11" - 14⅝" Adj. Pipe (279 - 372mm)

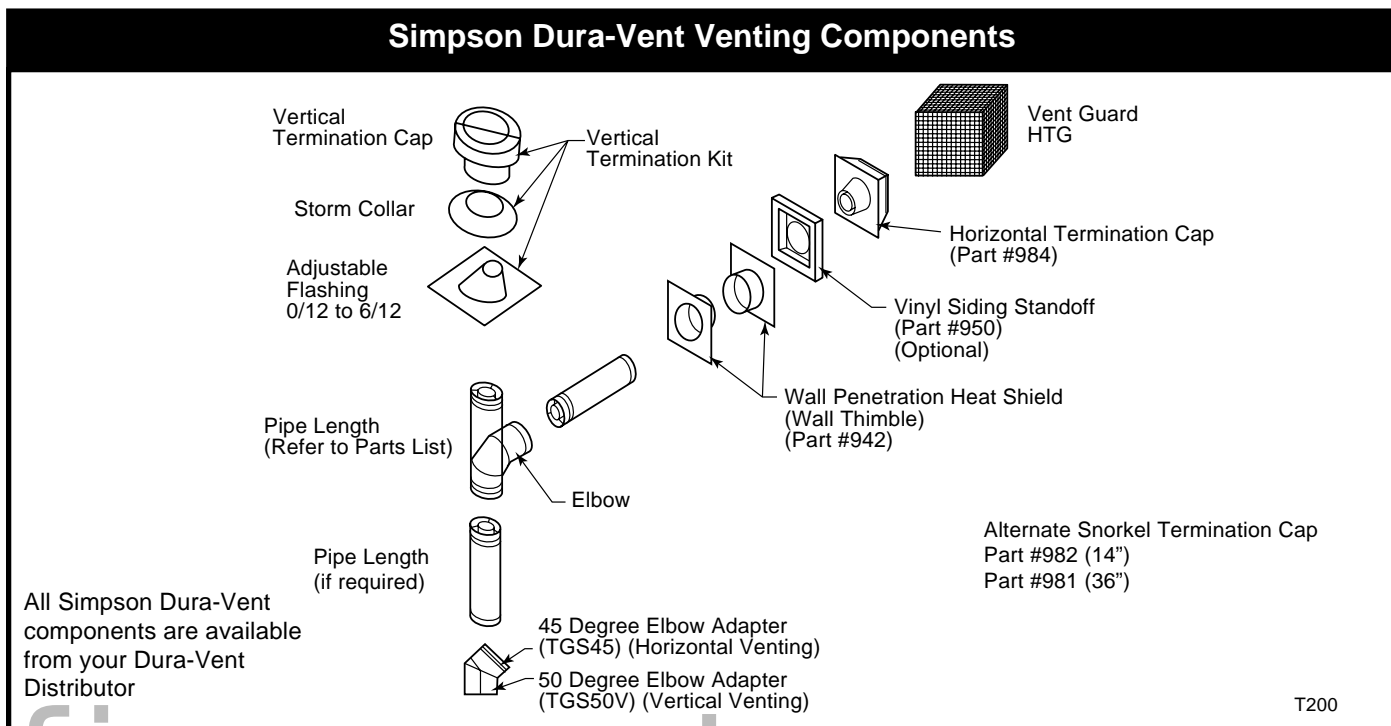

Horizontal Termination Kit	971	45° Elbow, Swivel - Black	945BG
Includes: 90° Black Elbow		90° Elbow - Galvanized	990
Wall Thimble Cover		90° Elbow, Swivel - Galvanized	990G
Horizontal Square Termination Cap		90° Elbow, Swivel - Black	990BG
24" Black Pipe		High Wind Termination Cap (Vertical)	991
11" - 14 1/2" Adjustable Black Pipe		Vertical Termination Cap	980
Basic Horizontal Termination Kit	970	Horizontal Square Termination Cap	984
Includes: 90° Black Elbow		Horizontal Square Termination Cap w/1" return	984L
Wall Thimble Cover		Horizontal Square High Wind Termination Cap	985
Horizontal Square Termination Cap		Snorkel - 14" Rise Termination Cap	982
Vertical Termination Kit	978	Snorkel - 36" Rise Termination Cap	981
Includes:		Wall Thimble - Support/Box	940
0-12 - 6/12 Pitch Adjustable Flashing		Cathedral Ceiling - Support/Box	941
Storm Collar		Brass Trim for Cathedral	3951
Low Profile Termination Cap		Firestop Spacer	963
6" Pipe Length - Black	908B	Flashing 0/12 - 6/12 Roof Pitch	943
9" Pipe Length - Black	907B	Flashing 7/12 - 12/12 Roof Pitch	943S
12" Pipe Length - Galvanized	906	Storm Collar	953
12" Pipe Length - Black	906B	Vinyl Siding Standoff	950
24" Pipe Length - Galvanized	904	Wall Strap	988
24" Pipe Length - Black	904B	Wall Penetration Heat Shield (Wall Thimble)	942
36" Pipe Length - Galvanized	903	Parts Available from TEMCO (Not supplied by Dura-Vent)	
36" Pipe Length - Black	903B	Vent Guard	HTG
48" Pipe Length - Galvanized	902	45° Adapter Elbow (Horizontal Venting)	TGS45
48" Pipe Length - Black	902B	50° Adapter Elbow (Vertical Venting)	TGS50V
11" - 14 1/2" Adjustable Pipe - Black	911B		
17" - 24" Adjustable Pipe - Black	917B		
45° Elbow - Galvanized	945		
45° Elbow - Black	945B		
45° Elbow, Swivel - Galvanized	945G		

Secure Vent Venting Components

Standard Horizontal Kit	SV0SHK	1½" - 6" Adjustable Pipe - Black	SV4LBA
Includes: 90° Swivel Black Elbow		1½" - 6" Adjustable Pipe - Galvanized	SV4LA
Decorative Black Plate		1½" - 12" Adjustable Pipe - Black	SV4LBA12
Horizontal Termination Cap		1½" - 12" Adjustable Pipe - Galvanized	SV4LA12
Horizontal Kit	SV0HK	1½" - 24" Adjustable Pipe - Black	SV4LBA24
Includes: 90° Swivel Black Elbow		1½" - 24" Adjustable Pipe - Galvanized	SV4LA24
Decorative black Plate		45° Elbow, Swivel - Black	SV4EB45
Horizontal Termination Cap		45° Elbow, Swivel - Galvanized	SV4E45
Adjustable Length 12"		45° Elbow - Black	SV4EBR45
Black Length 24"		90° Elbow, Swivel - Black	SV4EB90
Horizontal Kit	SV0HK2	90° Elbow - Galvanized	SV4E90
Includes: 90° Swivel Black Elbow		90° Elbow - Black	SV4EBR90
Decorative black Plate		Vinyl Shield	SV4VS
Horizontal Termination Cap		Snorkel Cap 14"	SV4STC14
Adjustable Length 12"		Snorkel Cap 36"	SV4STC36
Black Length 24"		Adjustable Decorative Square	
Wall Radiation Shield		Cathedral Support	SV4CSB
Vertical Flat Roof Kit	SV0FK	Wall Radiation Shield	SV4RSM
Flat Roof Flashing		Collar for Decorative Square	
Storm Collar		Cathedral Support	SV4AC
Vertical Termination Cap		Attic Radiation Shield	SV4RSA
Vertical Adjustable Roof Kit	SV0FAK	Adjustable Wall Band	SV4BM
1/12 - 7/12 Includes:		Roof Support	SV4ST
Adjustable Roof Flashing		Floor Support	SV4SD
(1/12 - 7/12)		Roof Brace	SV4BS
Storm Collar		Universal Support	SV4SU
Vertical Termination Cap		Flat Roof Flashing	SV4F
Vertical Adjustable Roof Kit	SV0FBK	1/12 - 7/12 Adjustable Roof Flashing	SV4FA
8/12 - 12/12 Includes:		8/12 - 12/12 Adjustable Roof Flashing	SV4FB
Adjustable Roof Flashing		Storm Collar	SV4FC
(8/12 - 12/12)		Decorative Black Plate	SV4PF
Storm Collar		Firestop	SV4BF
Vertical Termination Cap		Horizontal Termination Cap	SV4CHC
6" Pipe Length - Black	SV4LB6	Vertical Termination Cap	SV4CGV
6" Pipe Length - Galvanized	SV4L6	Restrictor Disc	SV4RD
12" Pipe Length - Black	SV4LB12	45° Adapter Elbow	
12" Pipe Length - Galvanized	SV4L12	(Horizontal Venting)	SV4E40AT*
24" Pipe Length - Black	SV4LB24		
24" Pipe Length - Galvanized	SV4L24		
36" Pipe Length - Black	SV4LB36		
36" Pipe Length - Galvanized	SV4L36		
48" Pipe Length - Black	SV4LB48		
48" Pipe Length - Galvanized	SV4L48		

*NOTE: This adapter elbow is required on all TEMCO Direct Vent Fireplaces for installation of Secure Vent Systems.

Operating Instructions



WARNING: Do not operate appliance with the glass front removed, cracked or broken.

- The use of substitute glass will void all product warranties.
- Care must be taken to avoid breakage of the glass.
- Do not operate this fireplace without the glass front or with a broken glass front.
- **Replacement of the glass should be done by a licensed or qualified service person.**
- **Do not remove the glass door when unit is hot to the touch.**
- **NOTE:** Inspect the door gasket. The braided door seal gasket has a small overlap area near the middle of the top black extrusion. Identify this area and install the door with this area at the top.

Glass Door Removal Procedure

1. Remove upper and lower louvre assemblies and set aside. Refer to louvre installation instructions.
2. Using gloves, carefully unlatch the latches (3) along the bottom edge of the glass door. Then as the top latches are unlatched, continue to place gentle pressure to the glass door to reduce the chances of the door being dropped accidentally.
3. Once all latches have been secured, pull the door (4) outward from the face of the fire chamber.
4. Take care during handling and cleaning of the glass door so that it is not dropped or accidentally broken.
5. Cleaning of the glass should only be done when the glass door is cool. Refer to Glass Cleaning section.
6. To reinstall glass door, carefully center the door onto the face of the fireplace (left to right), second, shift the door assembly upwards slightly, then secure door with the throw-over latches above and below the firechamber. By shifting the door upwards before latching, the upper door latches will be less visible once the upper louvre is installed.
7. Reinstall the upper and lower louvre assemblies. Refer to louvre installation.

Glass Cleaning

It will be necessary to clean the glass periodically. During start-up, condensation - which is normal - forms on the inside of the glass and causes dust, lint, etc. to cling to the glass surface. Also, initial paint curing can deposit a slight film on the glass. In some geographic areas, a white film may be deposited on the glass due to combustion of some of the constituents of natural gas. It is therefore recommended that initially the glass

be cleaned two or three times with non-abrasive common household cleansers and warm water. After that, the glass should be cleaned two or three times a season depending on the amount that the fireplace is used.

To remove, simply unlatch the top and bottom door latches and carefully pull door forward. Use of gloves recommended.



Do not clean when the glass is hot.

Do not strike or abuse glass.

Do not place glass door on edge after removal.

Louvre Installation

The fireplace is shipped without the louvre assemblies installed. Various styles and finishes are available as options. Contact your nearest Temco dealer/distributor for information on the Grill Kits available.

1. To install the upper louvre assembly, the second louvre blade from the top on each louvre assembly will hook onto the top tabs of the louvre brackets. (Fig. 30)
2. Once the second louvre blade has engaged the top tab of the end brackets, swing the bottom of the louvre assembly inward so the louvre hangs flush with the fireplace face. (Fig. 30)

After completing Steps 1 and 2, the louvre assembly should look like the illustration shown in Figure 31.

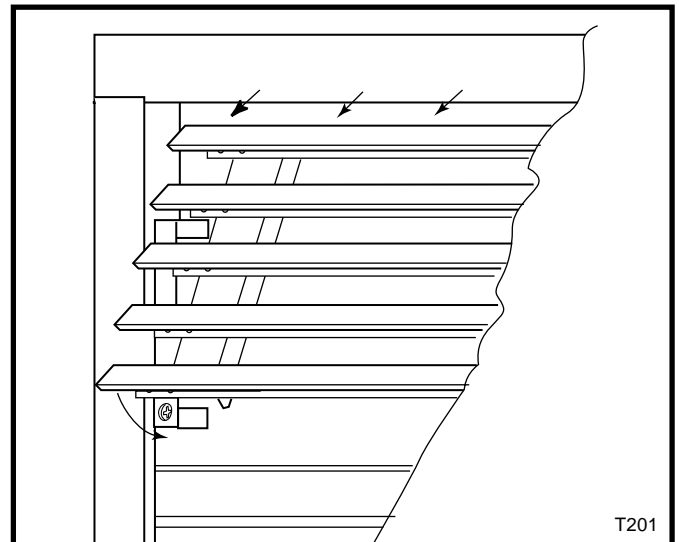

Fig. 30 Hook first or second louvre blade (depending on fireplace model) onto top tabs of louvre brackets.

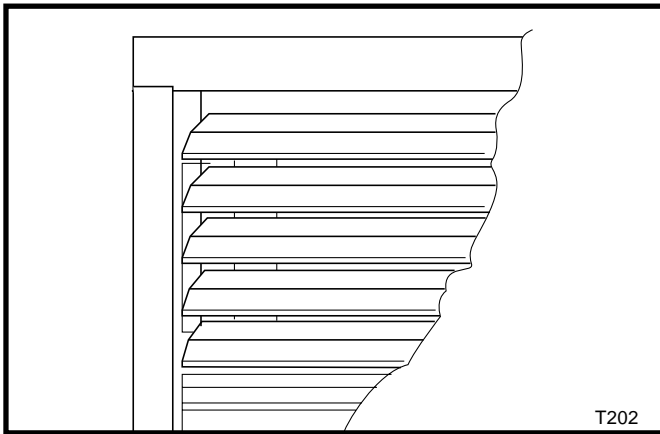

Fig. 31 Louvre in place.

Log Installation

Attention: Glass door should be removed when installing logset and prior to lighting the unit.

1. Remove glass door (Refer to "Glass Door Removal Procedure")
2. Remove logs from carton and inspect. Refer to Figures 32 and 34.
3. Rear log should be installed onto rear log supports. Match up slots on rear of log with the vertical log bracket tabs.
4. The center log should be placed on the center log supports, slots aligned with tabs, and log placed rearward.
5. Top twigs can then be placed in their designated positions provided with pins on back logs, and grooves on the center log. The two outside twigs provided on the DV6400 models rest on top of the ends of the grate. They are located and supported by the wire formed brackets extending up from the firebox base. (Fig. 34)



Fig. 32 Correct log placement for DV5200.

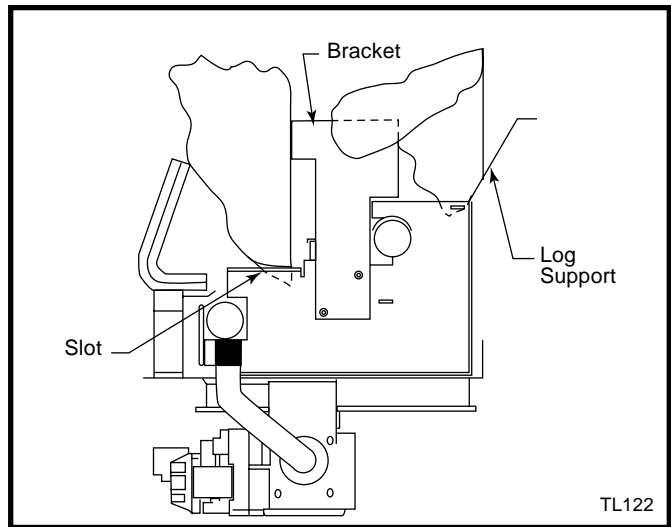

Fig. 33 DV5200 logs, side view.



Fig. 34 Correct log placement for DV6400. NOTE: Do not place side logs inside the flame.

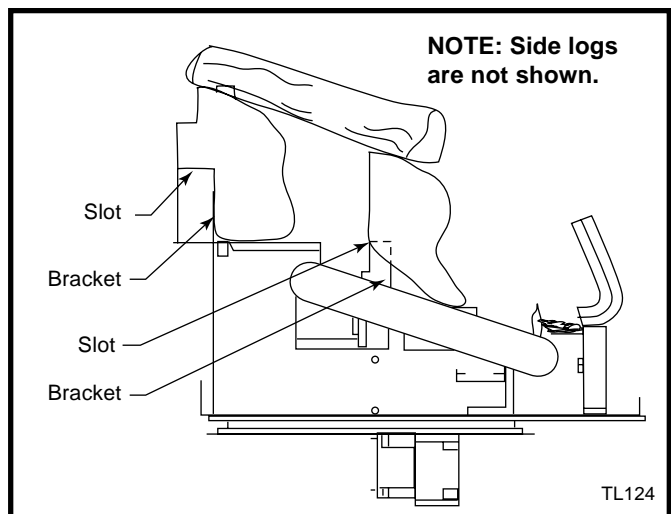

Fig. 35 DV6400 logs, side view.

6. Unpack steel wool and cut off a 1" x 3" (25 x 76mm) strip. Save the remainder of the steel wool for future use. Carefully stretch the strip out the full length of the burner's ported area and then place it on the ember tray allowing the steel wool to hang over the burner. Next, place the rock wool loosely on top of the steel wool and top edge of the ember retainer along entire length of ported area of front burner. Use individual pieces of rock wool about the size of a quarter. Rock wool should be fluffed up and not compressed. Rock wool must be held up by ember retainer tray. Do not allow embers to fall on burner and cover burner ports.
7. Ember tray ends beyond burner port area and area in front of grate may be covered with lava rock to suit individual appearance preferences.
8. Purge lines and test pilot operation.
9. Replace glass door. The door must be installed before operating the fireplace. (Refer to Page 24)
10. Flame should not impinge (touch) on logs.

WARNING: Do not place rock wool, lava rock or any other materials on the burner. Use only certified material supplied with this fireplace. Using uncertified materials will void the warranty.

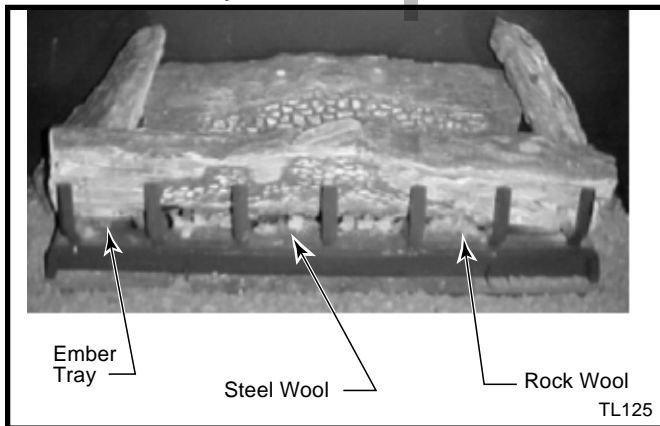

Fig. 36 Steel wool and rock wool placement.

Speed Control Switch

1. The blower combination on/off switch and electronic speed control is supplied loose to allow mounting in a conveniently located wall mounted electrical box.
2. Wire speed control into black (hot) side of 120V, 60Hz line as shown in blower wiring diagram.

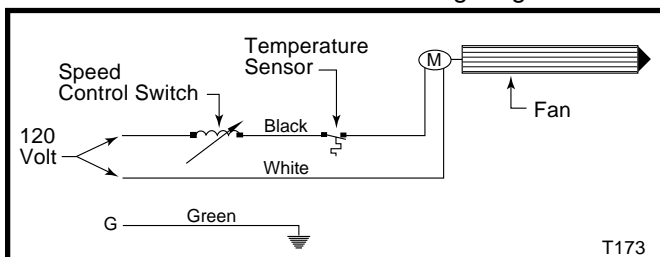

Fig. 37 Fan wiring diagram.



CAUTION: Should this fan require servicing, the power supply must be disconnected.

Millivolt System



CAUTION: At installation and/or after any service work or repairs glass door must be removed before proceeding to lighting instructions.



CAUTION: Label all wires prior to disconnection when servicing controls. Wiring errors can cause improper and dangerous operation.

Verify proper operation after servicing.

Burner On/Off Control

All models may be used with an optional wall switch that turns the main burner on or off. Optional millivolt thermostats (GFPMT) and remote control may be substituted for the wall switch (For installation of these options, detail instructions are provided with optional kits).

CAUTION: If the remote receiver is located in the gas control area (under the firebox), clearance should be below the firebox at least 2" (51mm) to avoid high temperatures (receiver should not be exposed to temperatures exceeding 130°F).

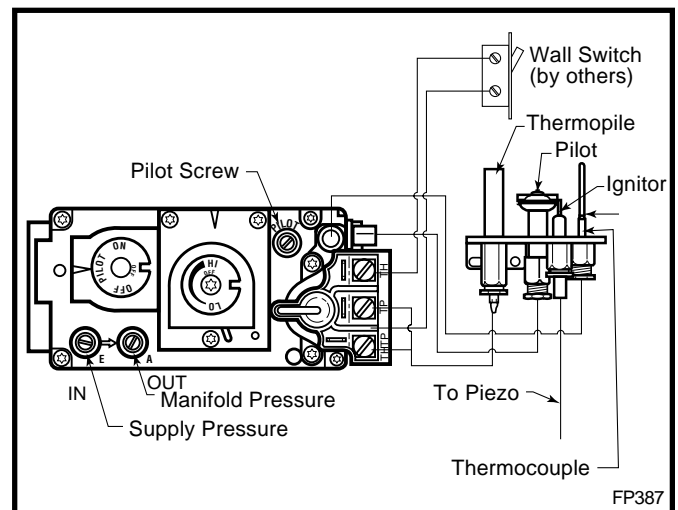

Fig. 38 Pilot and valve wiring.

Recommended Maximum Lead Length (Double Wire) When Using Wall Switch or Thermostat	
Wire Size	Max. Length
14 ga.	50' (15.2m)
16 ga.	32' (9.8m)
18 ga.	20' (6m)
20 ga.	15' (4.6m)
22 ga.	10' (3m)

NOTE: All Models are supplied with 15' (4.6m) of double wire for use with a wall switch.



CAUTION: Do not wire 120V power to millivolt switches or thermostats.

Managing Heat Output

The heat output from the appliance may be controlled by adjusting the main gas valve. Reference lighting instructions on Page 27 and chart on Page 33 showing inputs at all the settings.

The main gas valve may be adjusted anywhere between high and low to give the desired combination of flame aesthetics and heat output.

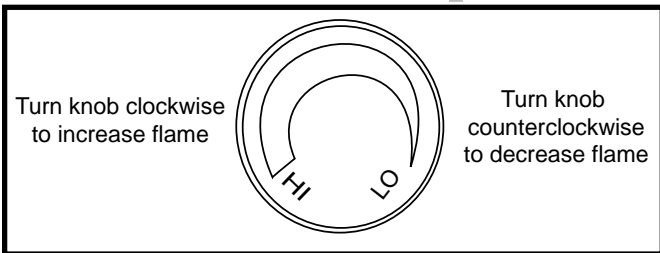

Fig. 39 Flame adjustment knob.

Fan Operation

The fan operates automatically - turn the knob on the speed control to adjust to the desired speed. The fan will turn on as the fireplace comes up to operating temperature. After the unit has been turned off and the unit cooled to below a useful heat output range the fan will shut off automatically.

Flame Characteristics

It is important to periodically perform a visual check of the pilot and burner flames. Compare them to Figure 40.

If the flame patterns appear abnormal, contact a qualified service provider for service and adjustment.

Pilot Burner Adjustment

1. Adjust pilot screw to provide proper sized flame.
2. Leak test.

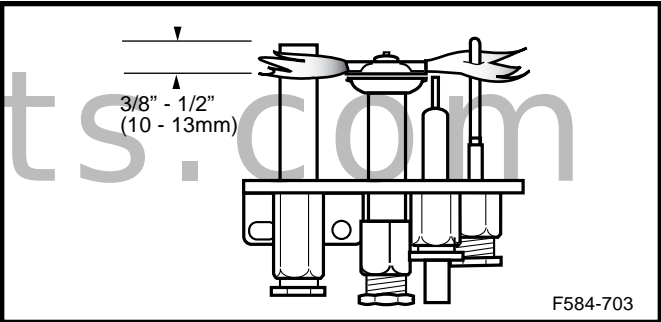

Fig. 40 Correct flame appearance.

Lighting and Operating Instructions

FOR YOUR SAFETY READ BEFORE LIGHTING

WARNING: If you do not follow these instructions exactly, a fire or explosion may result causing property damage, personal injury or loss of life.

- A. This heater has a pilot which must be lit manually. When lighting the pilot follow these instructions exactly.
- B. BEFORE LIGHTING smell all around the heater area for gas. Be sure to smell next to the floor because some gas is heavier than air and will settle on the floor.

WHAT TO DO IF YOU SMELL GAS

- Do not try to light any fireplace
- Do not touch any electric switch
- Do not use any phone in your building
- Immediately call your gas supplier from a neighbor's phone. Follow the gas supplier's

instructions.

- If you cannot reach your gas supplier, call the Fire Department
- C. Use only your hand to push in or turn the gas control knob. Never use tools. If the knob will not push in or turn by hand, do not try to repair it, call a qualified service technician. Applying force or any attempted repair may result in a fire or explosion.
- D. Do not use this fireplace if any part has been under water. Immediately call a qualified service technician to inspect the heater and to replace any part of the control system and any gas control which has been under water.

Lighting Instructions

1. **STOP!** Read the safety information above.
2. Turn off all electrical power to the fireplace.
3. Open the access door located at the bottom of the appliance to expose the controls.
4. If the control knob is not already in the "OFF" position, then push in the gas control knob slightly and turn clockwise  to "OFF".
NOTE: The knob cannot be turned from "PILOT" to "OFF" unless the knob is pushed in slightly. Do not force.

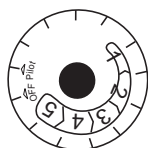

Euro SIT

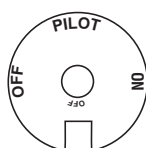

SIT NOVA



Honeywell

5. Wait five (5) minutes to clear out any gas. Then smell for gas, including near the floor. If you smell gas, STOP! Follow "B" in the safety information above. If you do not smell gas, go to the next step.
6. Push in the control knob slightly and turn it counterclockwise  to the "PILOT" position.
7. Push the control knob all the way in and hold. Push in red indicator button until you hear a click. Observe closely the pilot burner located on the

rear right hand side of the main burner. If a flame has appeared, continue to depress the control knob for 20 seconds. If the flame did not appear, continue to depress the red indicator button every 5 seconds until a flame is established. NOTE: If, after 30 seconds, a flame has not yet been established, turn the control knob back to the "OFF" position and repeat Steps 7 and 8.

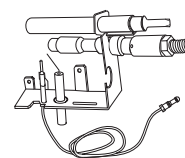
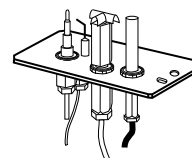
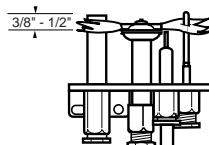

8. Once the pilot flame has been established, hold the control knob in the depressed position approximately 20 seconds before releasing. If the flame goes out, repeat Steps 6 and 7.
9. Now turn the control knob to the "ON" position. The burner will not light unless the wall switch, thermostat or remote control is turned on, or, in the case of a thermostat, there is a call for heat.
10. Close the access door and turn all electric power back to the appliance.

To Turn Off Gas To Heater

1. Turn off all electric power to the fireplace if service is to be performed.
2. Open control access panel.
3. Push in gas control knob slightly and turn clockwise  to "OFF". Do not force.
4. Close control access panel.

Troubleshooting

SIT Millivolt Valve

NOTE: Before troubleshooting the gas control system, be sure external shut off is in the "ON" position.



WARNING: Before doing any gas control service work, remove glass front!

Table 1				
Valve Type	Main Operator		Safety Magnet	
NOVA MV Plus	Minimum Voltage	145mV	Hold-in Current	Less than 285mA
	Coil Resistance	2.25Ω ± 0.5Ω	Drop-out Current	Greater than 125mA
			Coil Resistance	0.108Ω ± 0.003Ω

System Checks

Problem	Possible Cause	Solution
Pilot will not light.	Air in gas lines.	Bleed all air from gas lines.
	Defective spill switch.	Check for continuity across spill switch leads. Replace spill switch if excessive resistance is present, or if circuit is electrically open.
	Wrong inlet pressure.	With the main burner functioning, adjust the inlet pressure regulator to supply gas to the appliance within the design parameters of the appliance manufacturer. (Typically 7"NG, 11"LPG).
	Defective spark electrode.	Replace piezo wire if insulation is cracked or the tip is corroded. Verify that the spark gap between the pilot and the electrode is correct.
	Defective piezo wire.	Replace piezo wire if insulation is damaged, or the wire is broken or corroded.
	Safety interlock function engaged.	Allow thermocouple to cool until the mv drops below the hold-in requirements of the safety magnet, (30 seconds or less). Re-light pilot.
Pilot will not hold.	Wrong inlet pressure	With the main burner functioning, adjust the inlet pressure regulator to supply gas to the appliance within the design parameters of the appliance manufacturer. (Typically 7" NG, 11" LPG)
	Pilot adjustment screw not properly adjusted.	After the pilot has been lit for approximately three (3) minutes, and only the thermo-generator wire connected to the main operator head, measure the voltage across TPTH and TP. this open circuit voltage should be between 500mV and 750mv. Tune the pilot adjustment screw until the mV reading falls within these parameters. (Counterclockwise increases mV reading, clockwise decreases).
	Thermocouple or thermogenerator not properly inserted into the pilot housing.	Make certain that the thermocouple and thermogenerator are fully inserted and tightened into their receptacles in the pilot head. The thermocouple should be threaded into the valve hand-tight, plus 1/4 turn with a wrench.
	Thermocouple or thermogenerator has film build-up on tip.	With the thermocouple and thermogenerator tips cool, clean the upper 3/8" with a very fine emery cloth.
	Electrical resistance too high.	Using a very fine emery cloth, clean thermo-generator and thermocouple connections at valve. Tighten thermocouple into valve hand-tight, plus 1/4 turn with a wrench.

System Checks (continued)

Problem	Possible Cause	Solution
	Defective thermocouple. (mv Plus systems)	Verify that thermocouple is not kinked or damaged. Check open circuit voltage of thermocouple. Voltage should be between 18mv and 28mv. If voltage is less than 14mv, replace thermocouple.
	Defective thermo-generator. (Millivolt system)	After the pilot has been lit for approximately three minutes, and only the thermo-generator wire connected to the main operator head, measure the voltage across TPTH and TP. This open circuit voltage should be between 500mv and 750mv. Tune the pilot adjustment screw until the mv reading falls within these parameters. (Counter-clockwise increases mv reading, clockwise decreases)
	Defective safety magnet. (mv Plus systems)	Verify operation of safety magnet in the following manner. (A) Depress and hold pilot button. (B) Verify open-circuit thermocouple voltage as described in previous step. (C) Reconnect thermocouple to valve. (D) Measure the Millivoltage between the solder button on the base of the safety magnet, and the valve body. If the mv reading is above 6mv for vented appliances, or 8.5 mv for un-vented appliances, and the safety magnet does not hold, replace the valve. (E) If closed circuit mv reading is the same as the open circuit reading, the coil is electrically open. Replace the valve.
	Defective Safety Magnet (Millivolt system)	Verify operation of safety magnet in the following manner. (A) Remove all wires from the terminals of the main operator. (B) Measure the electrical voltage between the terminals TPTH and TP. If the voltage is above 110mv and the safety magnet does not hold, replace the valve.
	Pilot orifice blocked.	Replace orifice with a new orifice of the exact size and type.
Pilot drops out.	Wrong pilot orifice.	Replace the orifice with a new orifice supplied specifically for the appliance and gas type in question.
No gas to main burner	Low gas pressure to appliance.	With the main burner functioning, adjust the inlet pressure regulator to supply gas to the appliance within the design parameters of the appliance manufacturer. (Typically 7"NG, 11"LPG).
	Pilot not lit.	Light pilot and wait for thermo-generator to heat up sufficiently to power the main operator. If pilot fails to light, or hold, refer to above sections.
	Control knob not in ON position.	Rotate OFF/PILOT/ON control knob to the ON position.

System Checks (continued)

Problem	Possible Cause	Solution
Thermostat/wall switch will not cycle main burner.	Thermostat not in ON position.	Turn thermostat ON, and adjust temperature control to call for heat.
	Thermo-generator output voltage not within design parameters.	After the pilot has been lit for approximately three minutes, and only the thermo-generator wire connected to the main operator head, measure the voltage across TPTH and TP. This open circuit voltage should be between 500mv and 750mv. Tune the pilot adjustment screw until the mv reading falls within these parameters. (Counter-clockwise increases mv reading, clockwise decreases) If unable to meet minimum requirements, replace thermo-generator.
	Defective thermostat or thermostat wiring.	(A) With the pilot adjusted properly, (After the pilot has been lit for approximately three minutes, and only the thermo-generator wire connected to the main operator head, measure the voltage across TPTH and TP. This open circuit voltage should be between 500mv and 750mv. Tune the pilot adjustment screw until the mv reading falls within these parameters. Counterclockwise increases mv reading, clockwise decreases), place a jumper wire between TPTH and TH. Take a mv reading across the TPTH and TP terminals on the valve. This closed circuit voltage should not fall below 300mv. Record reading. (B) Remove jumper wire from the TPTH and TH connections, and reconnect the thermostat wires to the same terminals. Take the closed circuit voltage as described in the previous step. If the mv reading drops below 150mvm, excessive resistance exists in the thermostat circuit, and must be isolated and eliminated.
Thermostat/wall switch will not cycle main burner.	Defective wall switch.	Repeat the above troubleshooting items covered under "Defective thermostat or thermostat wiring", except substitute the words "wall switch" where the word "thermostat" appears in the instructions.
	Excessive wire resistance.	Make certain that all mv connections are made using wire of the proper size. (Reference Page 26).
	Valve wired wrong.	Thermo-generator leads must be connected to the TPTH and TP connections of the main operator. Thermostat wires must be connected to the TPTH , and TH terminals of the valve.
Main burner lights in the PILOT position.	Main operator coil defective.	Verify electrical resistance of main operator coil in the following manner. (A) Remove all wires from operator head. With an Ohm meter, measure electrical resistance between TP and TH terminals. If the resistance does not fall within specification, replace valve. (See table 1)
	Debris on seat of main valve.	Replace valve.
	Main seat blown out as a result of exposing LPG gas valve to unregulated line pressure in excess of 15 PSI.	Replace valve.

Maintenance

Once installed, the unit should be operated at least three (3) times to ensure that all is in working order.

NOTE: Manufacturing oils will smoke during initial firing of appliance. Open windows for ventilation.

Unit Adjustment

Before leaving, the installer should make the following checks:

Btu Input/Gas Pressure

The fireplace input is marked on the Rating Plate. The gas inlet pressure specified in Table 1 is the pressure where the field-installed gas line connects to the gas control. This is measured at the inlet test port on the gas valve in the appliance. Ensure that pressure is as shown in Table 1.

The manifold pressure is controlled by a regulator built into the gas control and should be checked at the pressure outlet test port located on the body of the gas valve.

The pressure should be checked with the appliance burning on high (highest setting) **and** all other gas appliances turned on. One must then read the manometer and if pressures are not as specified in Table 1, then the inlet pressure must be adjusted.

The appliance and its individual shut-off valve must be disconnected from the gas supply piping system during any pressure testing of the system at test pressures in excess of 1/2 psig (3.5 KPa).

Manifold pressure can be measured by using a 5/16" I.D. hose or tubing. Using a small blade screwdriver, back out the pressure screw for one full turn. Next, slip the tubing over the pressure tap extension to check the pressure with a manometer. Inlet and outlet pressure taps are located on the front (lower left side) of the valve body.

1. Tap on the left side of the valve will give inlet supply pressure.
2. Tap on the right side of the valve will give manifold pressure.

Pressure ranges are as listed below:

Table 1

	Gas Supply Pressure (inches w.c.)		
	Minimum	Normal	Maximum
Natural Gas	4.5"	7.0"	14.0"
LP (Propane)	10.8"	11.0"	14.0"
	Manifold Pressure (inches w.c.)		
	Normal (HI)	Normal (Low)	
Natural Gas	3.5"	1.6"	
LP (Propane)	10.0"	6.3"	

High Altitude

When installing this fireplace at an elevation between 0 and 2000 feet (0 - 610m) in the USA and 0 and 4500 feet (0 - 1370m) in Canada the input rating does not need to be reduced.

When installing this fireplace at an elevation above 2,000 feet (in the United States), it may be necessary to decrease the input rating by changing the existing burner orifice to a smaller size. Input should be reduced four percent (4%) for each 1,000 feet above sea level, unless the heating value of the gas has been reduced, in which case this general rule will not apply. To identify the proper orifice size, check with the local gas utility.

When installing this fireplace at an elevation above 4,500 feet (in Canada), check with local authorities.

Consult your local gas utility for assistance in determining the proper orifice for your location.

Main Burner/Pilot

The pilot flame size is factory set. The pilot flame should be at least 1 1/2" (38mm) long. The flame should be impinging on the pilot generator. Pilot size can be adjusted through the pilot adjust screw. If the pilot flame is too small and can not be adjusted through the pilot adjust screw then there is the possibility of dirt in the pilot orifice in which case the pilot orifice should be cleaned or replaced.

The main burner should be allowed to operate for 15 to 20 minutes before making any adjustment to the burner. The air shutter on the right front of the main burner should be adjusted so that there are no orange/red flames with dark sooty looking tips. A luminous yellow flame with blue base is what is acceptable. For burner air shutter settings see Air Shutter Settings chart. (Page 33)

If there is too much primary air then the flame will be very blue with yellow tips and smaller flame height. If there is too little primary air then the flame will be yellow with orange/red tips on the back flames with dark sooty elongated tips. In this condition the glass and logs could show signs of soot accumulation within 10 to 20 minutes.

Maintenance

Motor and Blower for Fan Kit (optional)

This motor has been factory oiled and under normal operating conditions should not require oiling.



WARNING: Ensure the power is turned off to the fireplace before servicing.

Cleaning

This unit should be cleaned and serviced by a Qualified Gas Technician at least annually. More frequent cleaning may be necessary if pet hair accumulates, dust and lint are present, or if the unit is located in a high traffic area. A Qualified Agency is defined in the Gas Code.

Cleaning should include burner tubes, orifice/injectors (refer to section B.3 National Fuel Gas Code), logs, ceramic base, and pilot assembly. It is recommended that the sediment trap in the gas line be emptied and cleaned at this time. (See Section 3.7.2 National Fuel Gas Code)

Burner, Pilot, Firebox and Logs



CAUTION: Before cleaning or moving logs or other parts of the unit, be sure to read the section on important safeguards.

Cleaning should be done before the logs are used each year and after long periods of non-use. All cleaning should be carried out when the appliance is cold. Cleaning will be required under normal use. Dusting the front grate or the control knob panel may be required occasionally. Do not use any cleaning fluids to clean the logs or any other part of the appliance.

If the flames show any unusual shapes or behavior, or if the burners fail to ignite properly, then the burner holes may require cleaning. If this occurs, contact your nearest dealer to get the appliance serviced.

Alternatively, the appliance can be cleaned by removing all the logs. Handle the logs gently so as not to damage them. Always lift each log by holding it carefully at each end.

After the logs are removed allowing access to the burner area, use a vacuum cleaner to carefully remove dust and loose particles from the base, logs and from around the burners. Gloves are recommended to prevent the ceramic fibers that compose the logs from pricking your skin. If the skin is pricked, wash gently with soap and water. Use extreme caution in cleaning around the pilot. The pilot should not be moved or altered from the original factory setting (Pilot to burner preset location). The burner should be placed back into its original locked and secure position after cleaning and servicing (proper location of burners are critical). **NOTE:** All replacements and repairs should be performed by a qualified technician (contact your nearest dealer). After cleaning and/or repairs, follow instructions for positioning of logs as illustrated on Page 24.

Glass

It will be necessary to clean the glass periodically. During startup it is normal for condensation to form on the glass and cause dirt, lint, etc., to adhere to the inner surface of the glass. There also will be a film deposited on the glass during the initial use of the fireplace due to initial curing of the paint. It is recommended that the glass be cleaned with a non-abrasive household cleaner and warm water. Be sure to rinse and dry the glass well as not to leave any marks. It will be necessary to clean the glass up to 3 times a season depending on use of the fireplace.

Glass Door Replacement

Only Temco parts should be used. Contact your nearest Temco dealer for replacement parts. Refer to Replacement Parts list on Page 34. Use only the glass door that is certified for use with the model listed.

Louvers/Trim/Surround

All gold, platinum, black anodized and painted surfaces should only be wiped off with a soft non-abrasive damp cloth (a mild dish soap can be used if necessary).

DO NOT use brass or other metal polishes, glass cleaners or any abrasive cleaners as this will mark and damage brass or painted surfaces.

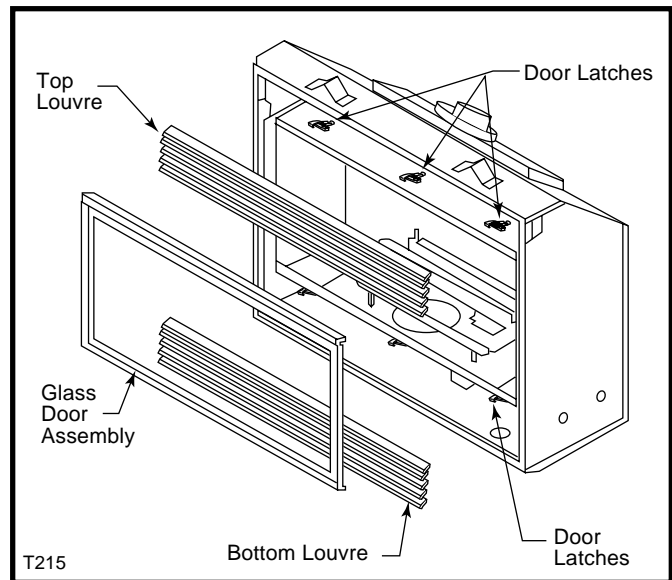

Fig. 41 Glass door assembly and louvers.

Normal and High Direct Vent Units - Inputs - Orifice Size - Altitude				
Model	BTU/Hr Min. Input	BTU/Hr Max. Input	Manifold Pressure @ Max.	Orifice 0 - 2000ft. Altitude in USA Orifice 0-4500ft Altitude in Canada
DV5200N	17,000	25,000	3.5" w.c.	#42 DMS
DV5200P	17,500	25,000	10.0" w.c.	1.45mm
DV6400N	18,000	27,000	3.5" w.c.	#40 DMS
DV6400P	17,500	25,000	10.0" w.c.	1.45mm

Conversion Kits		
Model	Change Natural to Propane	Change Propane to Natural
DV5200N	C36ACLP	--
DV5200P	--	C36ACNG
DV6400N	C36ACLP	--
DV6400P	--	DV6400CNG

IMPORTANT: Always check for gas leaks with a soap and water solution. Do not use open flame for leak testing.

Air Shutter Settings	
Model	Opening "A"
DV5200N	1/16" (1.6mm)
DV5200P	7/16" (11mm)
DV6400N	3/16" (4.7mm)
DV6400P	7/16" (11mm)

NOTE: These are minimum settings. Air shutter openings may be increased to prevent flame sooting.

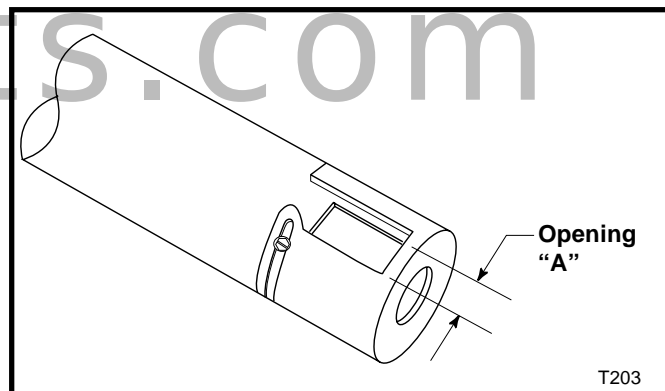

Fig. 42 Air shutter opening.

Replacement Parts

DV5200, DV6400

Description	DV5200	DV6400
Burner	77440	77440
Gasket Tape 5/8" Wide	75448	75447
Gas Valve LP (SIT)	76448	76448
Gas Valve NG (SIT)	76449	76449
Glass Door Assembly	75362	75361
Log Set	78369	76761
Log, Front	76895	76893
Log, Back	78016	75317
Log, Right Twig	75318	75318
Log, Left Twig	75319	75319
Log, Twig (Top)	--	76398
LP/Propane Burner Orifice	PCOAO70H37	PCOAO70H37
Natural Gas Burner Orifice	PCOAO70H04	PCOAO70H01
Piezo Ignitor	65180	65180
Pilot, Natural (SIT)	76261	76261
Pilot, Propane (SIT)	76335	76335
Pilot Orifice, Natural	76262	76262
Pilot Orifice, LP	76263	76263
Rep. Reg. Assembly LP Hi/Lo 82979	PCOB068	PCOB068
Rep. Reg. Assembly NG Hi/Lo 86354	PCOB069	PCOB069
Thermocouple	7531137	7531137
Thermopile	PCOB021	PCOB021
Grate Assembly	76485	77639
Rock Wool (Bag)	76675	76675
Stainless Steel (3" x 3" x 1")	77661	77661
Black Anodized Aluminum Grille Panels	GBL5200	GBL7400
Gold Colored Anodized Aluminum Grille Panels	GPB5200	GPB7400
Platinum Colored Anodized Aluminum Grille Panels	GPT5200	GPT7400

Always include correct name, part number, valve manufacturer, model number and serial number of the appliance when ordering service parts.

If you desire to communicate with the factory, write to Customer Service at:

Temco Fireplace Products
410 Admiral Blvd.
Mississauga, Ontario
Canada L5T 2N6

Servicing

Repair and replacement work should only be done by a qualified service person.

Always shut off the gas supply and make sure the appliance is cool before beginning any service operation.

Always check for gas leaks after servicing.

Limited Warranty

TEMCO Fireplace Products Direct Vent Gas Fireplaces

This warranty is limited to **TEMCO Fireplace Products** Direct Vent Gas Fireplaces (henceforth, Product) manufactured by **TEMCO Fireplace Products** (henceforth, TEMCO).

ONE YEAR WARRANTY

TEMCO warrants all components of the Product to be free of defects in materials and workmanship for a period of one year from the date of installation, with the exception of the warranty on logs and ember base. If, by the sole determination of **TEMCO**, any component covered under this warranty is found to be defective, **TEMCO** will, at its option, repair or replace the defective component at no charge and will pay labor cost incurred as specified in the current **TEMCO** Labor Allowance Schedule, 71313. If **TEMCO** determines replacement or repair is not economically practical, **TEMCO** will, at its option, refund the purchase price of the Product. Date of installation and purchase price must be verified by acceptable proof of purchase.

This warranty covers only parts and labor as provided above. In no case shall **TEMCO** be responsible for materials, components or construction which are not manufactured or supplied by **TEMCO**, or the labor necessary to install, repair or remove such materials, components or construction.

NOTE: If allegedly defective components need to be returned by TEMCO in connection with the above warranties, freight or postage charges must be prepaid.

QUALIFICATIONS

For the above warranties to apply:

The Product must be installed by a qualified installer; strictly in accordance with TEMCO installation instructions, and in compliance with local codes and ordinances. The logs must be placed strictly in accordance with the arrangement described in the installation instructions.

The Product must be operated and maintained according to the instructions furnished. **Alteration of the Product in any way is prohibited and voids any and all warranties. Removal of the data plate alters the Product and voids the warranty.**

The installer must have completed the installation and Startup Checklist, a copy of which must be submitted along with proof of purchase, to obtain prior approval for warranty repair or replacement and to affect a warranty claim. The Checklist is found on Pages 20 and 21 of this manual.

The limited warranty applies only to the original owner of the Product or the original owner of the dwelling in which the Product was installed. Use of any parts other than genuine factory provided replacement parts shall void this warranty.

Limitations

TEMCO is not responsible for any incidental or consequential damages caused by possible defects in the Product. The duration of any implied warranty with respect to the Product is limited to the duration of the foregoing warranties.

TEMCO is not responsible for any warranty repair (material or labor) for defects created by improper field conversions.

Some states and provinces do not allow exclusion of incidental or consequential damages or limits on the duration of implied warranties, so these limitations may not apply to you.

Warranty Fulfillment

Claims require specific agreement and consent from TEMCO Technical Services prior to performing any warranty repair or replacement. TEMCO reserves the right to investigate any and all warranty claims. The appliance must not be removed prior to such investigation other than on direction from **TEMCO**.

Please provide the following information when communicating with **TEMCO** Technical Services, its Dealers or Distributors regarding service under this warranty.

TEMCO reserves the right to decide on the method of settlement (if any). This limited warranty is given in lieu of any other expressed or implied warranty, and supersedes all other **TEMCO** Product warranties.

Model Number: _____
Serial Number: _____
Date of Installation: ____/____/____
Purchased From: _____

TEMCO FIREPLACE PRODUCTS DIRECT VENT FIREPLACES INSTALLATION AND STARTUP CHECKLIST

Customer Copy

NOTE: TEMCO Fireplace Products gas logs and fireplaces require installation by a qualified gas appliance installer. A copy of this checklist must be submitted, along with proof of purchase, when applying to Technical Services for prior written approval of warranty repair or replacement.

- Read and understand installation instructions before attempting installation.

Verify CORRECT FUEL TYPE

- Check carton model number.
- Check fireplace label. Models ending in N are for natural gas; those ending in P are for propane (LP gas).

WARNING: Using the incorrect fuel can create a serious fire hazard and will void the warranties. Install in accordance with local and/or national codes and ordinances. Follow the TEMCO installation instructions.

- Supply service shutoff valve upstream of gas fireplace.
- Gas line size adequate for input rating (BTU's per hour) of fireplace, per National Fuel Gas Code (NFPA54) in the case of USA installations or Installation Code CAN 1-149 in the case of Canadian installations.

Make following checks:

- Gas line integrity at supply line connection.
- Glass front panel position.
- Correct gas pressure. Inlet Pressure _____ (inches w.c.) Manifold Pressure _____ (inches w.c.)
- Piezo ignitor function (millivolt control models only).
- Pilot ignition.
- Main burner ignition.
- Proper flame pattern and color.
- Positioning of logs (in accordance with instructions).
- Clearances to combustibles (vent, framing, mantels, etc.).
- Vent system in compliance with instructions. All joints and connections sealed.
- Wall switch operation. Do not connect millivolt wiring, wall switch or valve to 120v line voltage unless units is specifically DSI equipped.
- Demonstrated proper operating procedure to homeowner.
- Explained the need for proper cleaning and maintenance.
- Check all fittings and connections for gas leaks, correct if necessary.

Please sign below that checklist has been completed and understood. DATE INSTALLED ____/____/____

Installer Phone Consumer Phone

TEMCO FIREPLACE PRODUCTS DIRECT VENT FIREPLACES INSTALLATION AND STARTUP CHECKLIST

Installer's Copy

NOTE: TEMCO Fireplace Products gas logs and fireplaces require installation by a qualified gas appliance installer. A copy of this checklist must be submitted, along with proof of purchase, when applying to Technical Services for prior written approval of warranty repair or replacement.

- Read and understand installation instructions before installing.

Verify CORRECT FUEL TYPE

- Check carton model number.
- Check fireplace label. Models ending in N are for natural gas; those ending in P are for propane (LP gas).

WARNING: Using the incorrect fuel can create a serious fire hazard and will void the warranties. Install in accordance with local and/or national codes and ordinances. Follow the TEMCO installation instructions.

- Supply service shutoff valve upstream of gas fireplace.
- Gas line size adequate for input rating (BTU's per hour) of fireplace, per National Fuel Gas Code (NFPA54) in the case of USA installations or Installation Code CAN 1-149 in the case of Canadian installations.

Make following checks:

- Gas line integrity at supply line connection.
- Glass front panel position.
- Correct gas pressure. Inlet Pressure _____ (inches WC) Manifold Pressure _____ (inchesWC)
- Piezo ignitor function (millivolt control models only).
- Pilot ignition.
- Main burner ignition.
- Proper flame pattern and color.
- Positioning of logs (in accordance with instructions).
- Clearances to combustibles (vent, framing, mantels, etc.).
- Vent system in compliance with instructions. All joints and connections sealed.
- Wall switch operation. Do not connect millivolt wiring, wall switch or valve to 120v line voltage unless units is specifically DSI equipped.
- Demonstrated proper operating procedure to homeowner.
- Explained the need for proper cleaning and maintenance.
- Check all fittings and connections for gas leaks, correct if necessary.

Please sign below that checklist has been completed and understood. DATE INSTALLED ____/____/____

Installer

Phone

Consumer

Phone

Customer Copy

Model # _____

Serial # _____

I certify that I have followed all codes and regulations and adhered to the TEMCO Fireplace Products installation instructions. I have completed the proper installation and startup checklist.

Installer's Signature

Purchaser _____

Address _____

Phone _____

Retailer _____

Address _____

Phone _____

Date of Purchase _____

Print Installer's Name

WARRANTY REGISTRATION

Please answer the following questions (Check Box):

- 1. Type of Home Single Family Duplex Apt.
 Mobile Home Cabin/Vacation
- 2. Installed in(Room) Living Family Great Rec
 Bedroom Other
- 3. Other Choices Considered: Vented Decorative Gas Log/Fireplace Woodburning Fireplace
 Gas Insert Woodburning Insert
 Direct-Vent Gas Fireplace/Logs
- 4. Why did you choose Direct Vent? (Rank in order of importance: 1-6)
 Appearance Location Flexibility
 Builder Decided Other



To register your warranty, please provide the information indicated on this form and mail it to:

TEMCO Fireplace Products
Attn: Warranty Registration
410 Admiral Blvd.
Mississauga, Ontario Canada L5T 2N6

Model # _____

Serial # _____

I certify that I have followed all codes and regulations and adhered to the TEMCO installation instructions. I have completed the proper installation and startup checklist.

Installer's Signature

Purchaser _____

Address _____

Phone _____

Retailer _____

Address _____

Phone _____

Date of Purchase _____

Print Installer's Name

WARRANTY REGISTRATION

Please answer the following questions (Check Box):

- 1. Type of Home Single Family Duplex Apt.
 Mobile Home Cabin/Vacation
- 2. Installed in(Room) Living Family Great Rec
 Bedroom Other
- 3. Other Choices Considered Vented Decorative Gas Log/Fireplace Woodburning Fireplace
 Gas Insert Woodburning Insert
 Direct-Vent Gas Fireplace/Logs
- 4. Why did you choose Direct Vent? (Rank in order of importance: 1-6)
 Appearance Location Flexibility
 Builder Decided Other